

PARTS LIST:

1	Driver/left Running Board	12	10-1.5mm Nylon Lock Nuts
1	Passenger/right Running Board	12	8mm x 24mm x 2mm Washers
3	Driver/left Mounting Brackets	12	8mm Lock Washers
3	Passenger/right Mounting Brackets	12	8-1.25mm x 30mm Hex Bolts
12	10-1.5mm x 35mm Hex Bolts	6	8mm Nylon Lock Nuts
24	10mm x 27mm x 3mm Washers		

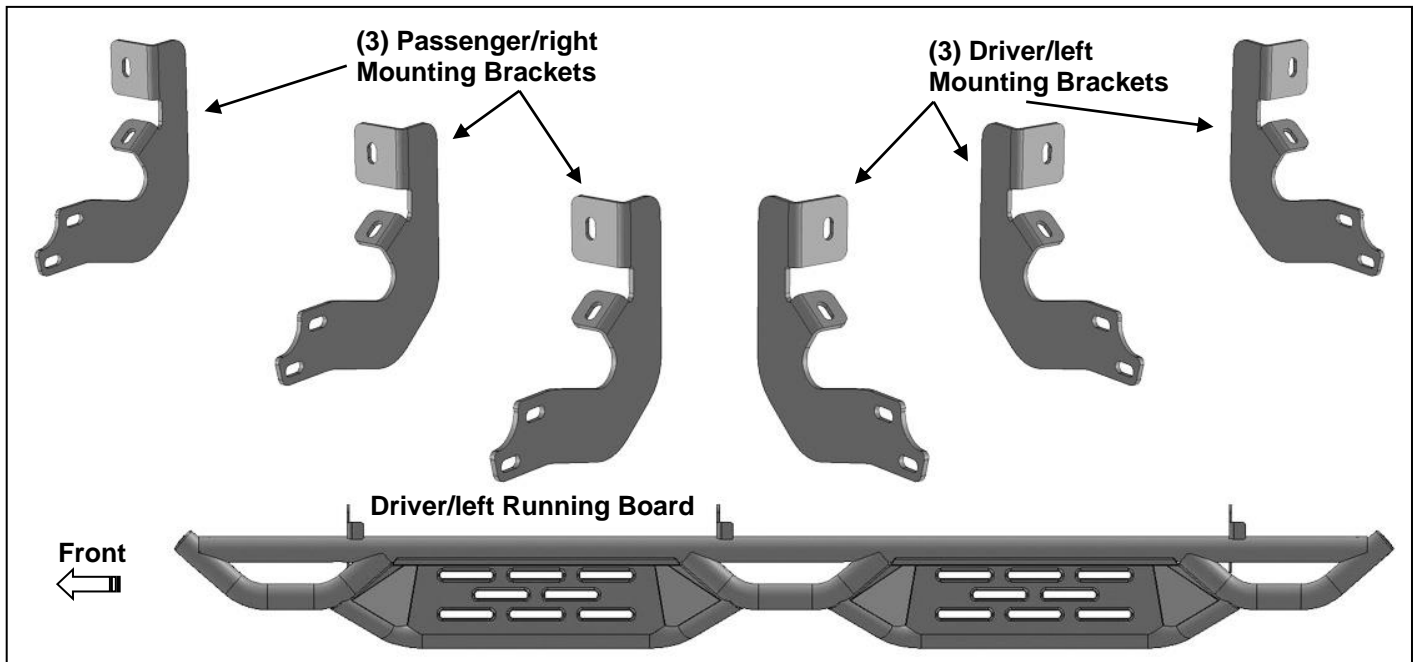

PROCEDURE:

REMOVE CONTENTS FROM BOX. VERIFY ALL PARTS ARE PRESENT. READ INSTRUCTIONS CAREFULLY BEFORE STARTING INSTALLATION. ASSISTANCE IS RECOMMENDED.

1. Start installation at the front of the driver/left side of the vehicle. Locate the factory threaded stud and/or the threaded holes located on the side of the inner body panel, **(Figures 1 & 2)**. **NOTE:** Remove the plastic plug or any insulation on the side panel to locate the threaded holes. Use a wire brush to remove paint or undercoating from the threaded stud if equipped.
2. Select (1) Driver/Left Mounting Bracket. Determine if the vehicle is equipped with (1) threaded stud and (1) threaded hole or (2) threaded mounting holes.

Models with threaded stud and lower threaded mounting hole, (Figure 1):

- a. Attach Bracket to stud with (1) 8mm Flat Washer and (1) 8mm Nylon Lock Nut.
- b. Next, use (1) 8mm Hex Bolt, (1) 8mm Lock Washer and (1) 8mm Flat Washer to attach the lower mount on the Bracket to the threaded hole on the body panel, **(Figure 3)**. Do not tighten hardware.

Models with (2) threaded holes only, (Figure 2):

- a. Attach Bracket to the (2) threaded holes with (2) 8mm Hex Bolts, (2) 8mm Lock Washers and (2) 8mm Flat Washers, **(Figure 3)**. Do not tighten hardware.

3. Repeat **Steps 1 & 2** to install the center and rear Mounting Brackets.
4. Carefully unwrap and select the driver/left Running Board. **IMPORTANT:** The front and center mounting tabs on the Running board are slightly closer to the front end of the Running Board.
5. With assistance, line up the Running Board with the front of the Mounting Brackets. Attach the tabs on the Running Board to the front facing side of the Brackets with (6) 10mm x 35mm Hex Bolts, (12) 10mm Flat Washers and (6) 10mm Nylon Lock Nuts, **(Figures 4 & 5)**. Do not tighten hardware at this time.
6. Level and adjust the Running Board as necessary and fully tighten all hardware.
7. Repeat **Steps 1—6** for the passenger/right side Running Board installation.
8. Do periodic inspections to the installation to make sure that all hardware is secure and tight.

To protect your investment, Do not use any type of polish or wax that may contain abrasives that could damage the finish. Mild soap may be used also to clean the Running Board.

Driver/left Side Installation Pictured

Use a wire brush to remove paint from threads

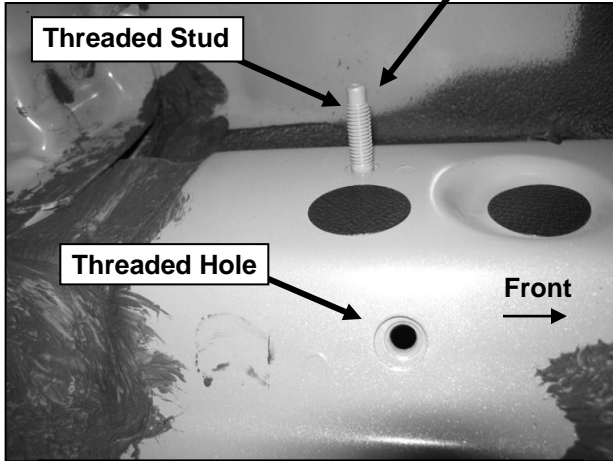

(Fig 1) Example of up to 2015 driver/left mounting location. Note: Remove plastic plugs to locate factory threaded holes

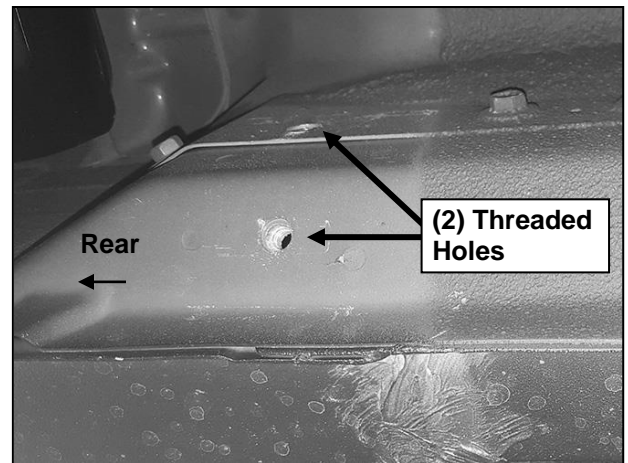

(Fig 2) Example of 2016-on driver/left mounting location. Note: two factory threaded holes only

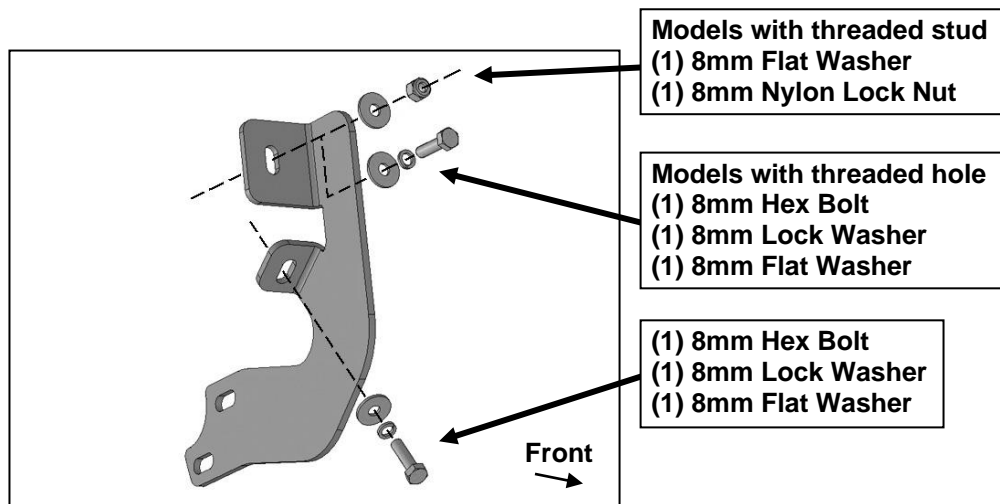

Models with threaded stud
(1) 8mm Flat Washer
(1) 8mm Nylon Lock Nut

Models with threaded hole
(1) 8mm Hex Bolt
(1) 8mm Lock Washer
(1) 8mm Flat Washer

(1) 8mm Hex Bolt
(1) 8mm Lock Washer
(1) 8mm Flat Washer

(Fig 3) Typical driver/left side Mounting Bracket installation illustrated

Driver/left Side Installation Pictured

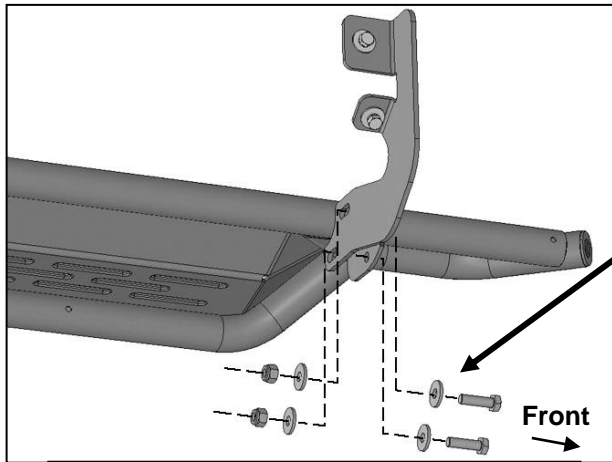

- (2) 10mm Hex Bolts
- (4) 10mm Flat Washers
- (2) 10mm Nylon Lock Nuts

(Fig 4) Attach driver/left Running Board to front of front Mounting Bracket

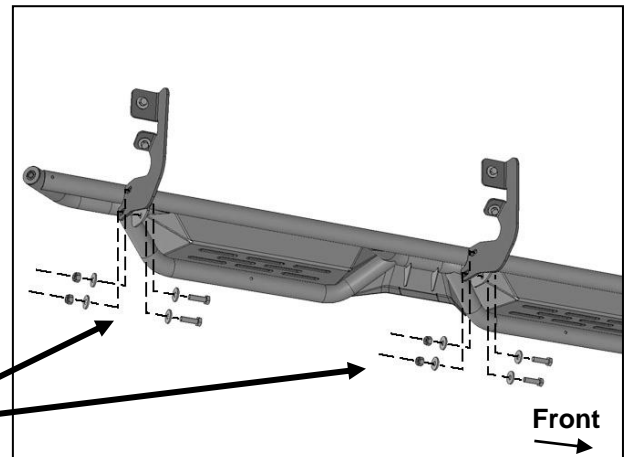

- (2) 10mm Hex Bolts
- (4) 10mm Flat Washers
- (2) 10mm Nylon Lock Nuts

(Fig 5) Attach driver/left Running Board to front of center and rear Mounting Brackets

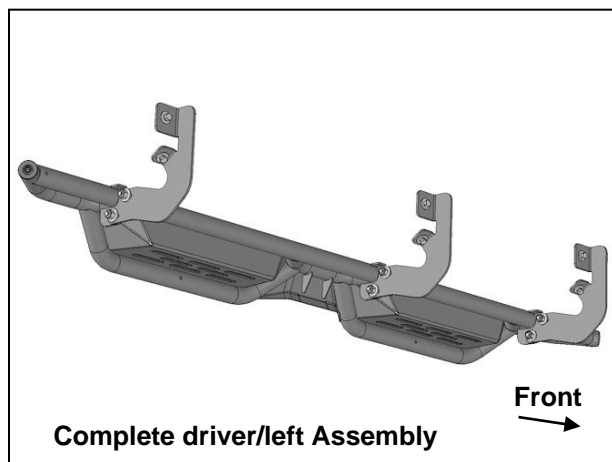

Complete driver/left Assembly