

## INSTALLATION INSTRUCTIONS

**PARTS LIST:**

Qty	Item Description	Qty	Item Description
1	Driver/Left Running Board(51")	12	10mm x 30mm x 2.5mm Flat Washers
1	Passenger/Right Running Board(51")	8	10mm Lock Washers
1	Driver/Left Front Mounting Bracket	4	10mm Hex Nuts
1	Passenger/Right Front Mounting Bracket	4	8-1.25mm x 35mm Hex Bolts
1	Driver/Left Rear Mounting Bracket	8	8-1.25mm x 25mm Combo Bolts
1	Passenger/Right Rear Mounting Bracket	4	8mm x 28mm x 3mm Flat Washers
2	Driver/Left Support Bracket	4	8mm Lock Washers
2	Passenger/Right Rear Support Bracket	8	6-1.0mm x 25mm Hex Bolts
4	10mm x 1.5mm Hex Nut Plates	16	6mm x 22mm x 2mm Flat Washers
4	10-1.5mm x 30mm Hex Bolts	8	6mm Nylon Lock Nuts
4	10-1.5mm x 35mm Hex Bolts		

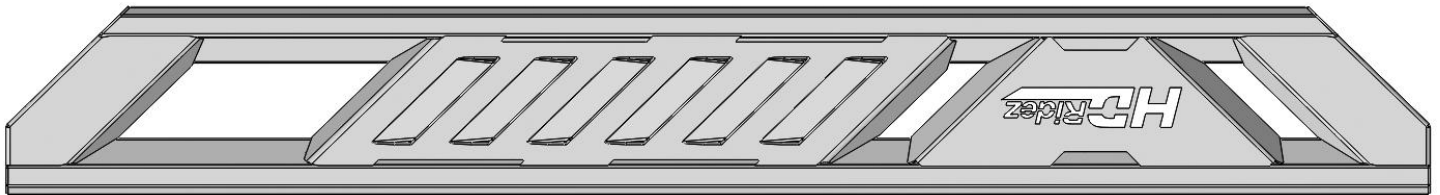

**Front** Passenger/Right Side Running Board

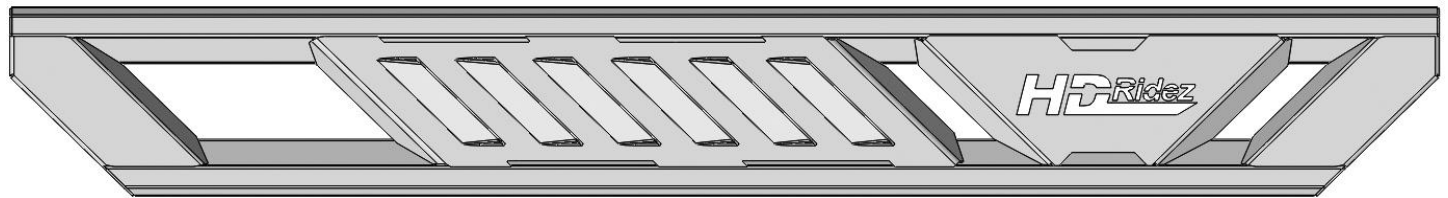

Driver/Left Side Running Board

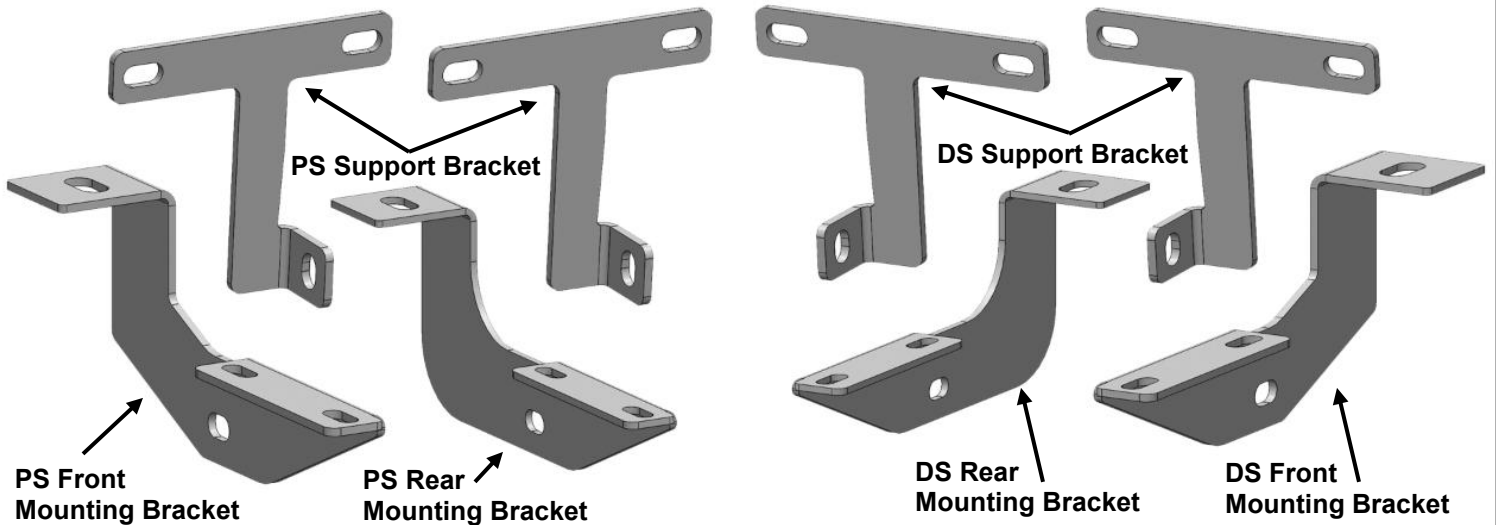

Lock Washer



Lock Nut



Flat Washer

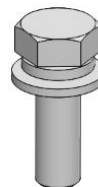



Combo Bolt

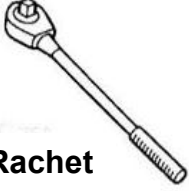

Hex Bolt

**TOOLS REQUIRED**

 <p>Ratchet</p>	 <p>Socket</p>	 <p>Extensions</p>	 <p>Wrench</p>
--	---	--	---

**1**

Follow (Fig 1 – 6) to attach Passenger/Right Mounting Brackets and Support Brackets. Ensure hardware is hand tightened. Repeat the following steps on the Driver Side.

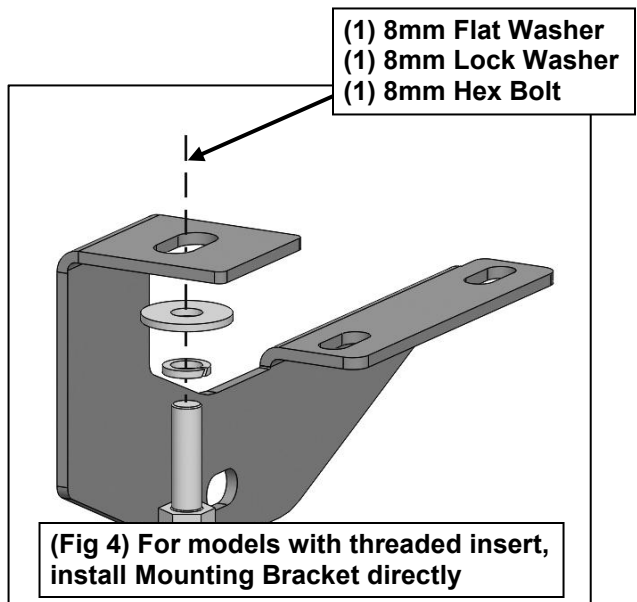
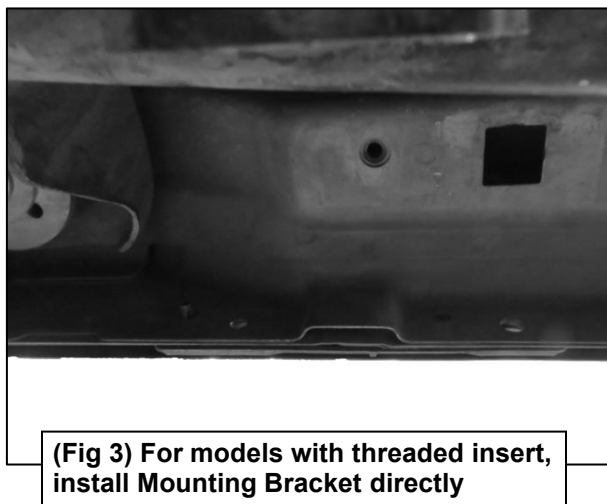
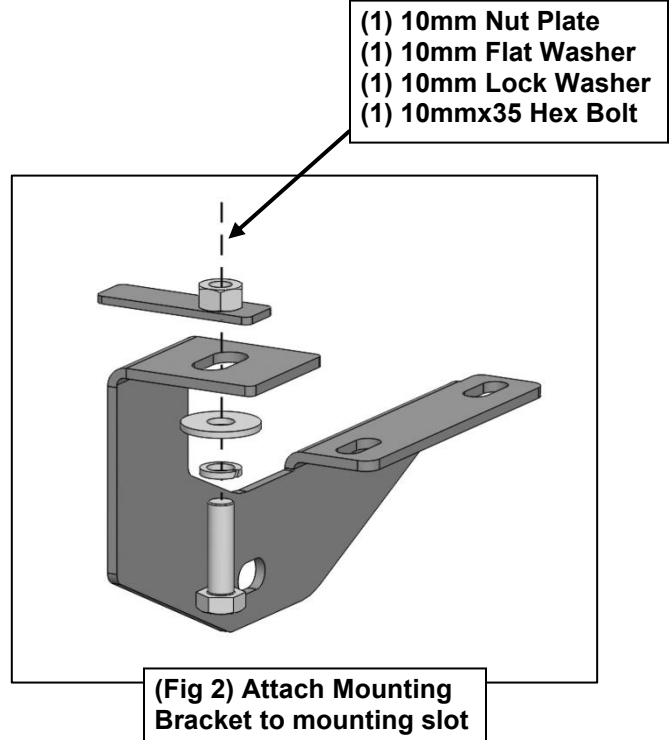
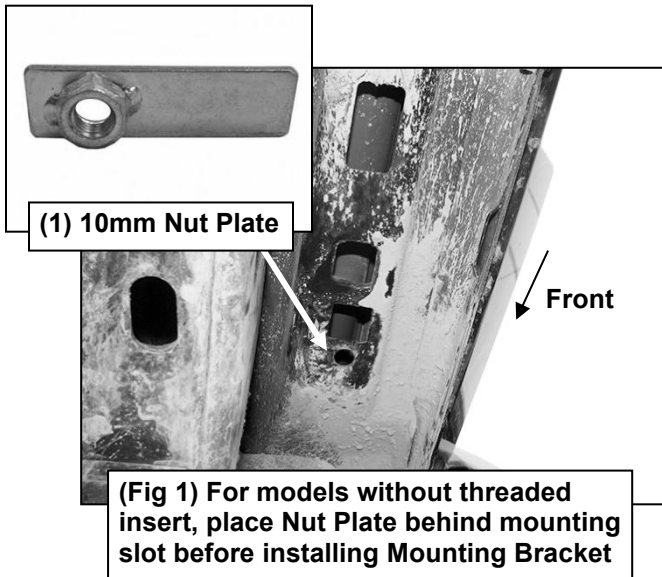

**SR1 Running Board  
2007-2018 Jeep Wrangler JK 2 Door**

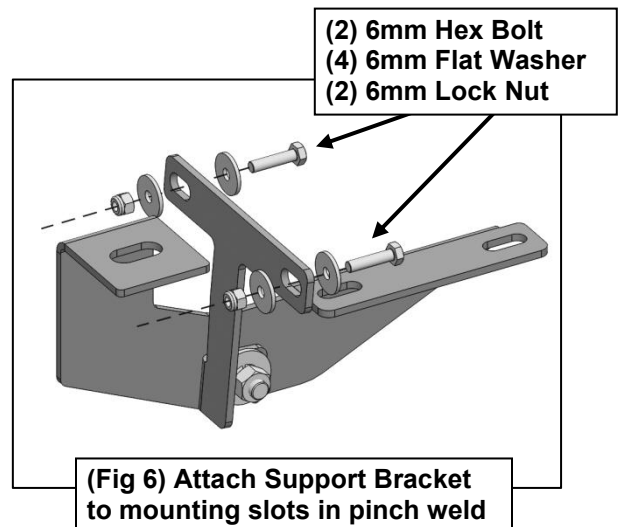
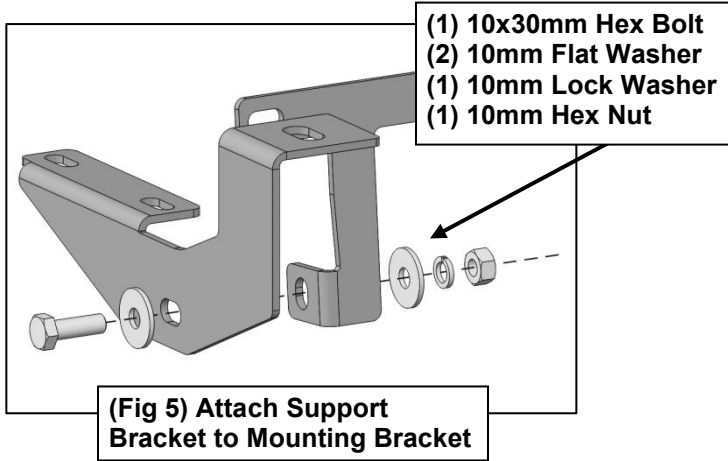

**2**

Follow (Fig 7 – 8) to attach Passenger/Right Running Board to Mounting Brackets. Ensure hardware is hand tightened. Repeat on Driver/Left side.

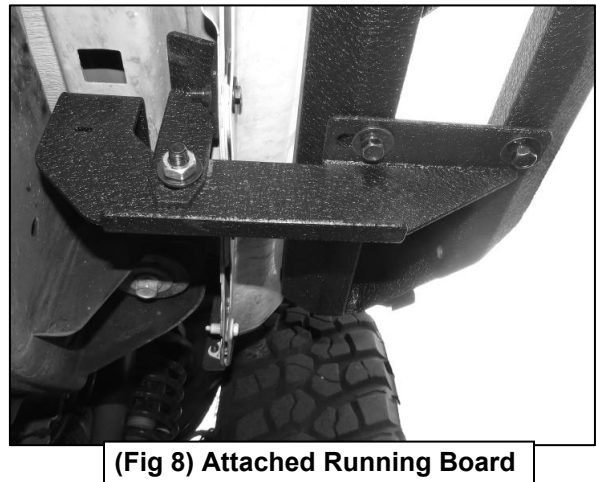
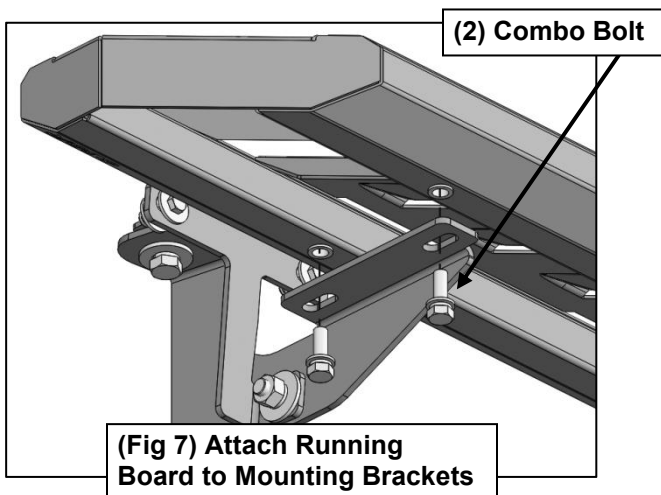

**3**

Installation is complete. Do periodic inspections to the installation to make sure that all hardware is secure and tight.

