

PARTS LIST:

1	Driver/left Running Board	16	10mm x 27mm x 3mm Washers
1	Passenger/right Running Board	8	10-1.5mm Nylon Lock Nuts
4	Mounting Brackets (left or right)	12	8mm x 24mm x 2mm Washers
12	8mm Plastic Retainers	12	8-1.25mm Nylon Lock Nuts
8	10-1.5mm x 35mm Hex Bolts		

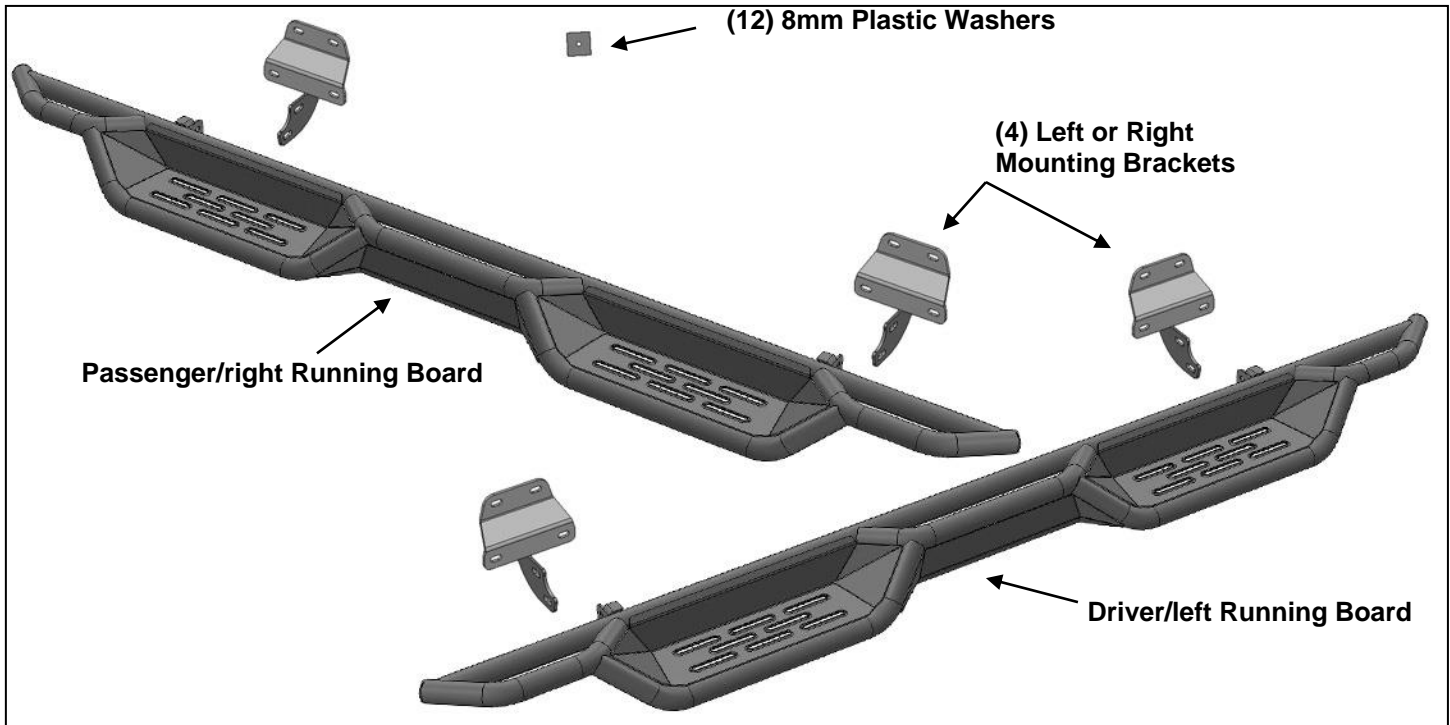

PROCEDURE:

REMOVE CONTENTS FROM BOX. VERIFY ALL PARTS ARE PRESENT. READ INSTRUCTIONS CAREFULLY BEFORE STARTING INSTALLATION. ASSISTANCE IS RECOMMENDED.

1. Start the installation under the driver/left side of the vehicle. Locate the front factory running board mounting location along the inner side of the body, **(Figure 1)**.
2. Slide (1) Plastic Washer over each of the (3) factory mounting studs in the body panel, **(Figure 3)**. **IMPORTANT:** The Plastic Washers are designed to prevent corrosion between the aluminum body panel and the steel mounting brackets. **Do not install the Brackets without the Plastic Washers.**
3. Select (1) Mounting Bracket. **NOTE:** All (4) Brackets are universal and will fit left or right side. Attach the Mounting Bracket to the (3) factory studs with (3) 8mm Flat Washers and (3) 8mm Nylon Lock Nuts, **(Figures 4 & 5)**. Leave brackets loose at this time.
4. Repeat **Steps 1—3** to install the remaining driver side rear Bracket.
5. Carefully unwrap and select the driver/left Running Board. **IMPORTANT:** The front mounting tab on the Running board for the front Bracket is slightly closer to the end of the tube than the rear mounting tab, **(Figure 6)**.
6. With assistance, line up the Running Board with the back of the Brackets. Attach the tabs on the Running Board to the rear facing side of the Brackets with (4) 10mm x 35mm Hex Bolts, (8) 10mm Flat Washers and (4) 10mm Nylon Lock Nuts, **(Figures 7 & 8)**. Do not fully tighten hardware at this time.
7. Level and adjust the Running Board as necessary and fully tighten all hardware.
8. Repeat **Steps 1—7** for the passenger/right side Running Board installation.
9. Do periodic inspections to the installation to make sure that all hardware is secure and tight.

To protect your investment, wax this product after installing. Regular waxing is recommended to add a protective layer over the finish. Do not use any type of polish or wax that may contain abrasives that could damage the finish. Mild soap may be used also to clean the Running Board.

Driver/left Side Installation Pictured

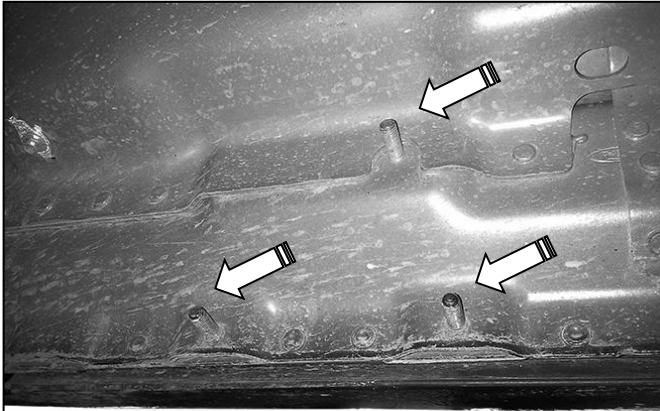

(Fig 1) Typical mounting location

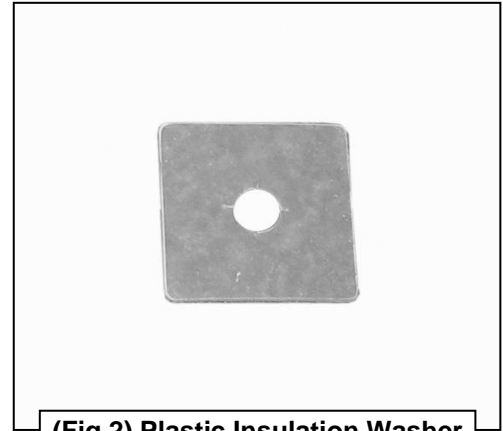

(Fig 2) Plastic Insulation Washer

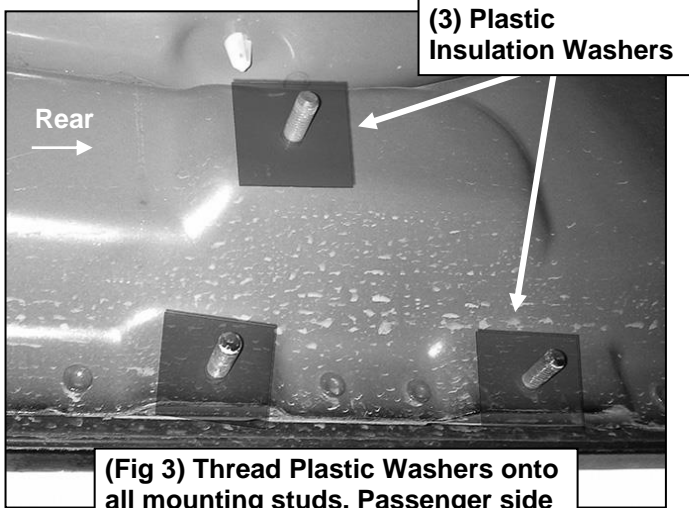

(Fig 3) Thread Plastic Washers onto all mounting studs. Passenger side rear mounting location pictured

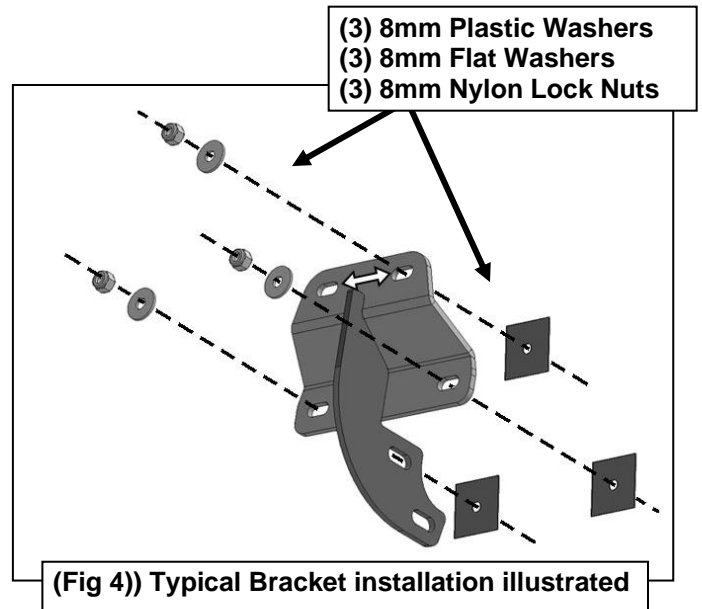

(Fig 4) Typical Bracket installation illustrated

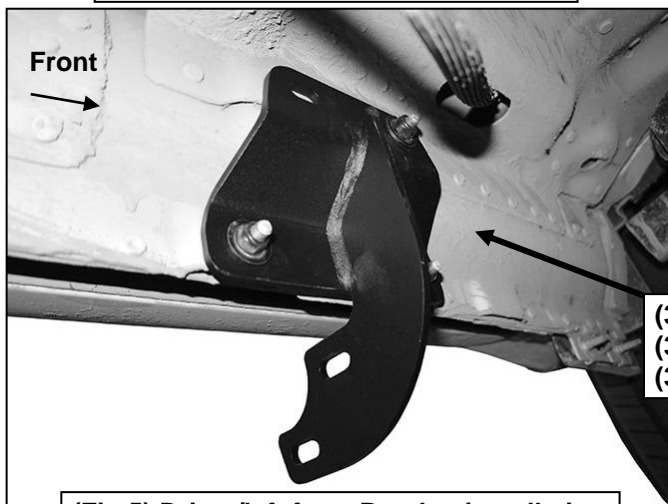

- (3) 8mm Plastic Washers
- (3) 8mm Flat Washers
- (3) 8mm Nylon Lock Nuts

(Fig 5) Driver/left front Bracket installation

Driver/left Side Installation Pictured

