

**NB1 WHEEL TO WHEEL RUNNING BOARDS  
2015-24 FORD F150 SUPER CAB 6.5FT BED  
2017-24 F250/350 SUPER CAB 6.5FT BED**

**PARTS LIST:**

1	Driver/Left NB1 Running Board	4	10mm x 20mm OD x 2mm Flat Washers
1	Passenger/Right NB1 Running Board	4	10mm Lock Washers
4	Front Mounting Brackets	12	10mm Nylon Lock Nuts
1	Driver/Left Rear Mounting Bracket	4	10mm Hex Nuts
1	Passenger/Right Rear Mounting Bracket	8	10mm Plastic Retainers
2	10mm x 40mm T-Bolts	12	8mm x 24mm OD x 2mm Flat Washers
2	10mm x 35mm Long Bolt Plates	12	8mm Nylon Lock Nuts
12	10mm x 35mm Hex Bolts	12	8mm Plastic Retainers
24	10mm x 27mm OD x 3mm Flat Washers		

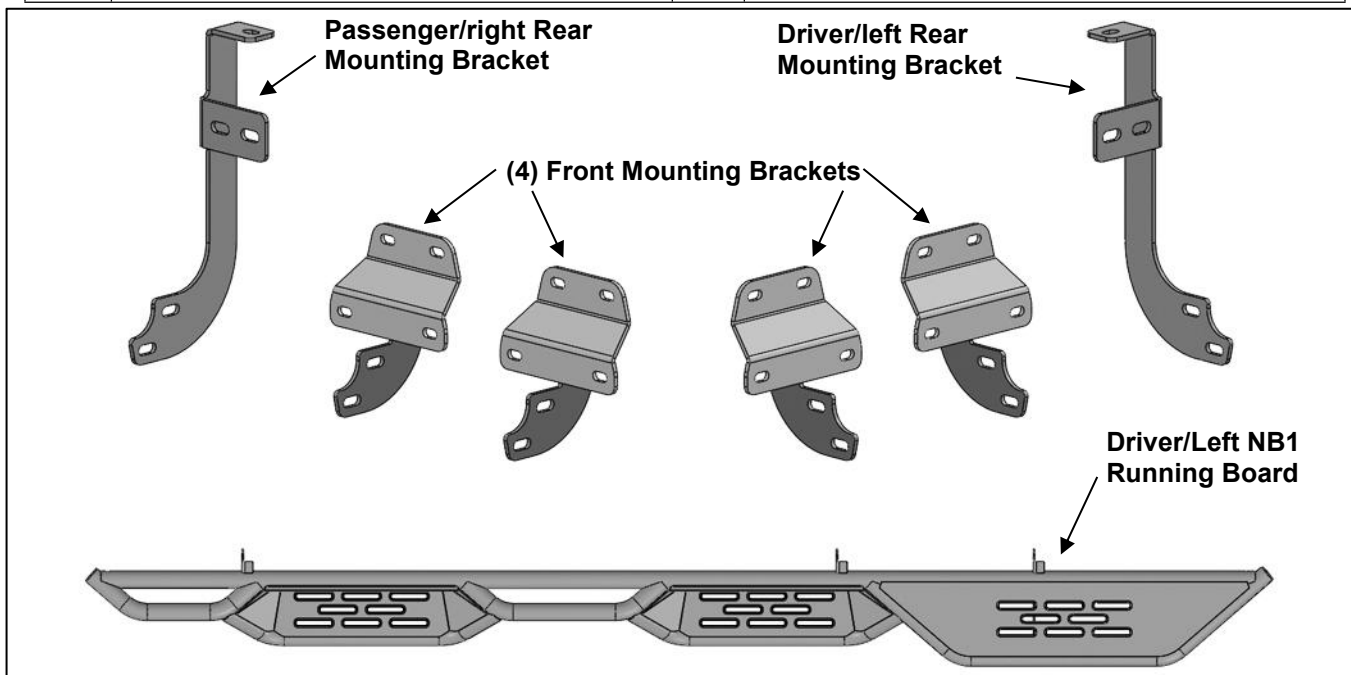

**PROCEDURE:**

**REMOVE CONTENTS FROM BOX. VERIFY ALL PARTS ARE PRESENT. READ INSTRUCTIONS CAREFULLY BEFORE STARTING INSTALLATION. ASSISTANCE IS RECOMMENDED.**

1. Start the installation under the driver side of the vehicle. Locate the front factory running board mounting location along the inner side of the body, **(Figure 1)**.
2. Slide (1) Plastic Washer over each factory mounting stud in the body panel, **(Figures 2 & 3)**.  
**IMPORTANT:** The Plastic Washers are designed to prevent corrosion between the aluminum body panel and the steel mounting brackets. **Do not install the Brackets without the Plastic Washers.**
3. Select (1) Mounting Bracket. **NOTE:** The (2) Brackets that attach to the (2) factory mounting locations are universal and will fit left or right side. Attach the Mounting Bracket to the (3) factory studs with (3) 8mm Flat Washers and (3) 8mm Nylon Lock Nuts, **(Figures 4 & 5)**. Do not tighten hardware.
4. Repeat **Steps 1—3** to install (1) Front Mounting Bracket to the center location.
5. Move to the rear body mount at the back of the cab. Locate the oval hole in the body mount support directly above the square hole in the side of the body panel, **(Figure 6)**. Thread (1) 10mm Plastic Washer onto (1) 10mm x 40mm T-Bolt, **(Figure 7)**. Thread the Plastic Washer all the way down the threaded end of the T-Bolt. By hand, (pliers can also be used), bend the sides of the Plastic Washer up around the sides of the Bolt Plate, **(Figure 8)**.
6. Insert the Bolt Plate and Washer into the oval hole. Once the Bolt Plate is in the hole, thread a second Plastic Washer down until it is tight against the body panel, **(Figure 9)**. If necessary, use scissors to trim plastic washer for easier installation. **IMPORTANT: Do not install the rear Bolt Plates and Brackets without the Plastic Washers.**

**NB1 WHEEL TO WHEEL RUNNING BOARDS  
2015-24 FORD F150 SUPER CAB 6.5FT BED  
2017-24 F250/350 SUPER CAB 6.5FT BED**

7. Next, locate the square hole in the side of the body panel, **(Figure 6)**. Select the 10mm Bolt Plate and (1) 10mm Plastic Washer, **(Figure 10)**. Repeat **Steps 5 & 6** to insert the Bolt Plate and Plastic Washer into the square hole. Trim Plastic Washer as required, **(Figure 11)**. Once the Bolt Plate is in the hole, thread a second Plastic Washer down until it is tight against the body panel, **(Figure 12)**.
8. Select the Driver/Left Rear Mounting Bracket. Slide the Bracket over the (2) Bolt Plates. Attach the Bracket to the Bolt Plates with (2) 10mm x 20mm Flat Washers, (2) 10mm Lock Washers and (2) 10mm Hex Nuts, **(Figure 13)**. Leave hardware loose at this time.
9. Select the Driver/Left Running Board. With assistance, carefully line up the slots on the front faces in the (3) Mounting Brackets to the slots in the mounting tabs on the Running Board. Secure the Running Board to the Mounting Brackets with (6) 10mm Hex Bolts, (12) 10mm x 27mm Flat Washers and (6) 10mm Nylon Lock Nuts, **(Figure 14)**. Do not tighten hardware.
10. Level and adjust the Running Board, then tighten all hardware.
11. Repeat **Steps 1—10** to install the Passenger/Right NB1 Running Board.
12. Do periodic inspections to the installation to make sure that all hardware is secure and tight.

**To protect your investment**, Do not use any type of polish or wax that may contain abrasives that could damage the finish. Mild soap may be used to clean the Running Boards.

**Driver/left Sidebar Installation Pictured**

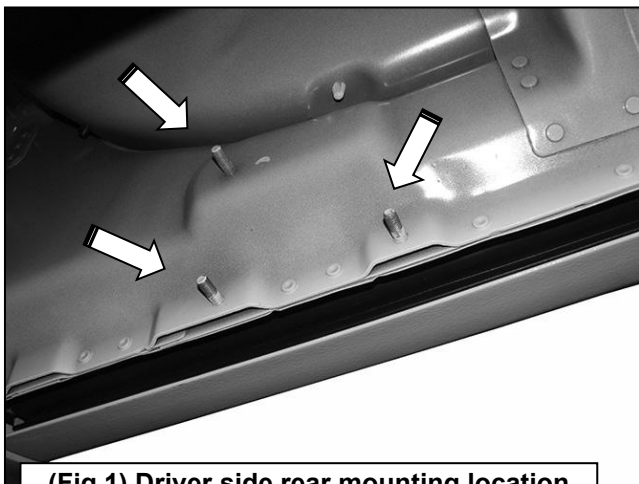

**(Fig 1) Driver side rear mounting location**

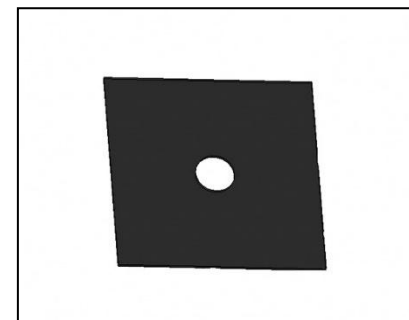

**(Fig 2) Plastic Insulation Washer**

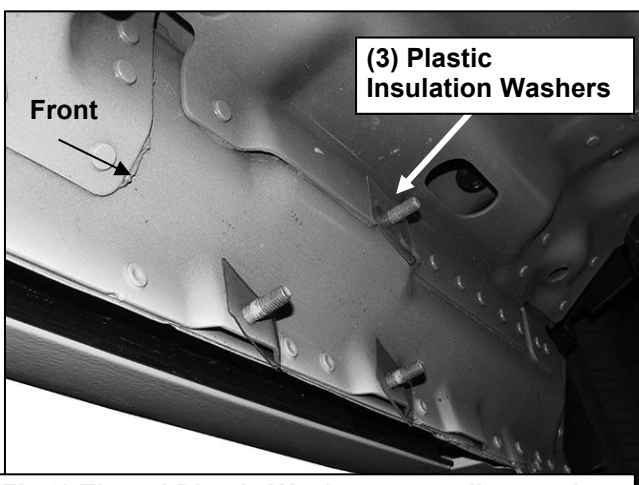

**(Fig 3) Thread Plastic Washers onto all mounting studs. Driver side front location pictured**

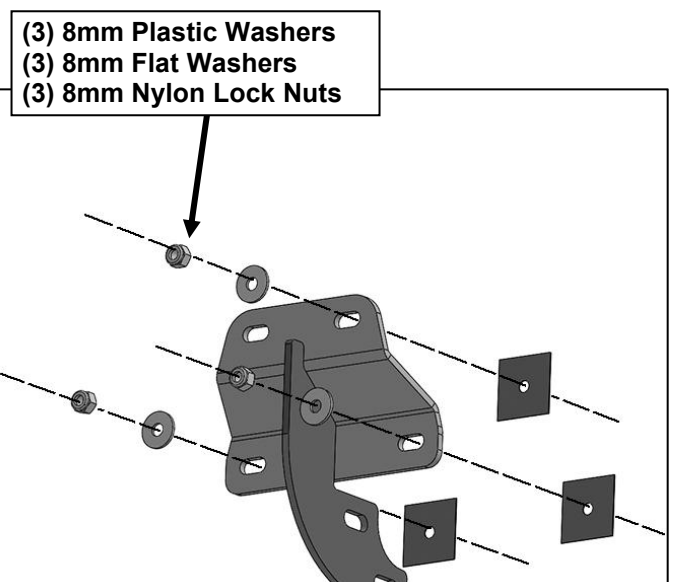

**(Fig 4) Typical Bracket installation illustrated**

**NB1 WHEEL TO WHEEL RUNNING BOARDS  
2015-24 FORD F150 SUPER CAB 6.5FT BED  
2017-24 F250/350 SUPER CAB 6.5FT BED**

**Driver/left Sidebar Installation Pictured**

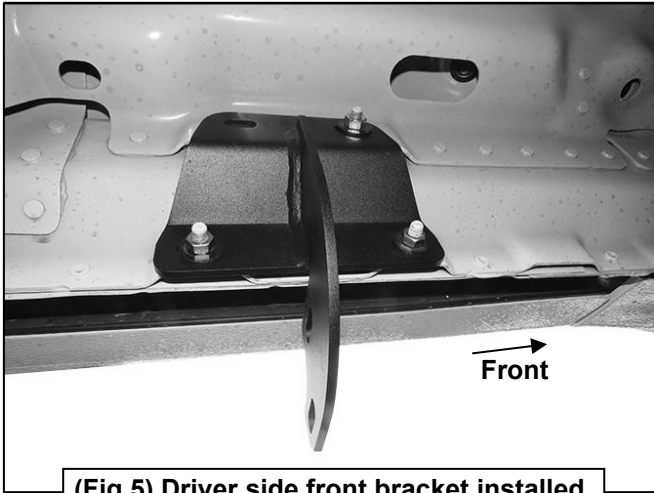

**(Fig 5) Driver side front bracket installed**



**(Fig 6) Driver side rear mounting location**



**(Fig 7) 10mm T-Bolt with Plastic Washer**

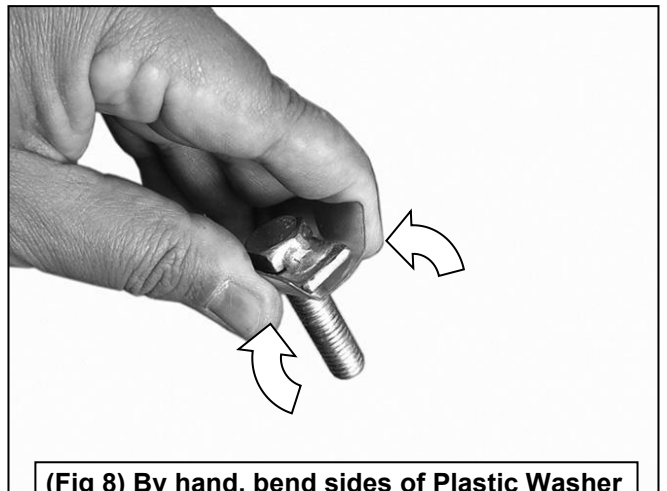

**(Fig 8) By hand, bend sides of Plastic Washer up around T-Bolt (pliers may also be used)**



**(Fig 9) Insert T-Bolt and folded Washer into oval hole. Thread second Plastic Washer onto T-Bolt**

**NB1 WHEEL TO WHEEL RUNNING BOARDS  
2015-24 FORD F150 SUPER CAB 6.5FT BED  
2017-24 F250/350 SUPER CAB 6.5FT BED**

**Driver/left Sidebar Installation Pictured**

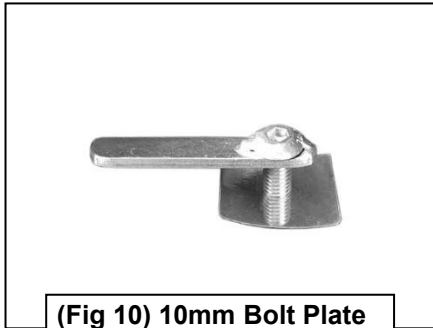

**(Fig 10) 10mm Bolt Plate with Plastic Washer**

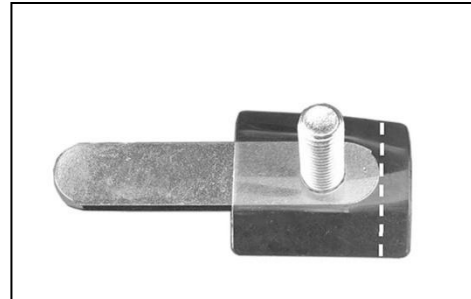

**(Fig 11) Bend sides of Plastic Washer up around Bolt Plate. If necessary, use scissors to cut off overhanging plastic. Cut washer on Bolt Plate installation only**

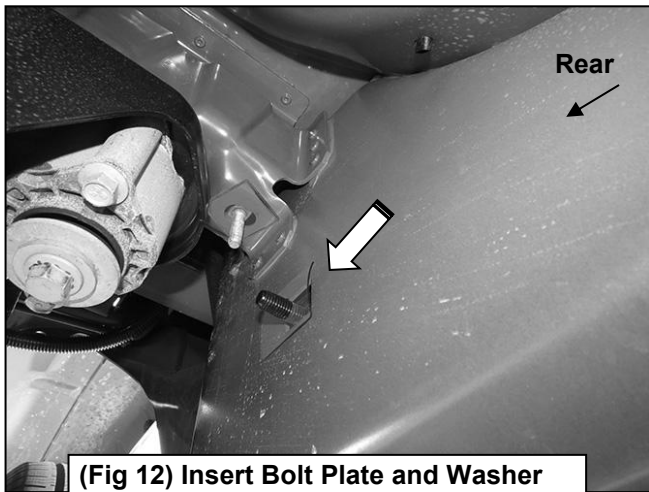

**(Fig 12) Insert Bolt Plate and Washer into lower square hole. Thread second Plastic Washer onto Bolt Plate**

- (2) 10mm x 20mm Flat Washers**
- (2) 10mm Lock Washers**
- (2) 10mm Hex Nuts**

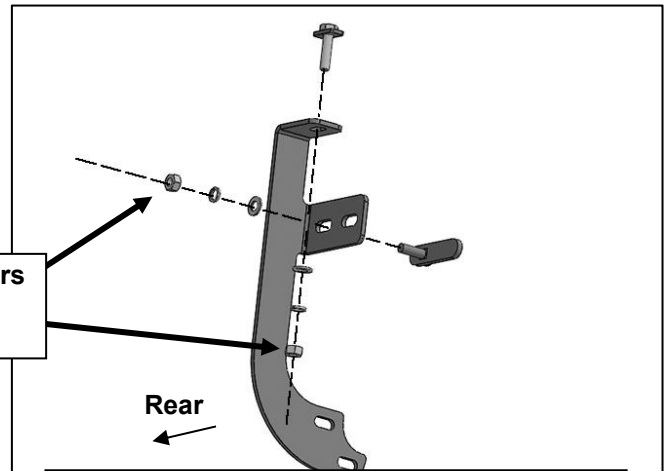

**(Fig 13) Driver side rear Bracket installation**

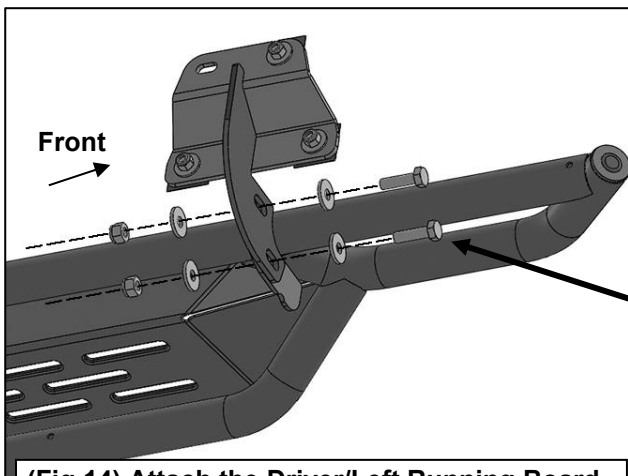

**(Fig 14) Attach the Driver/Left Running Board to the front faces of the (3) Mounting Brackets**

- (2) 10mm Hex Bolts**
- (4) 10mm x 27mm Flat Washers**
- (2) 10mm Nylon Lock Nuts**