

NB1 WHEEL TO WHEEL RUNNING BOARDS
09-18 DODGE RAM 1500 CREW CAB 6.5FT BED (INCL. 19-24 RAM 1500 CLASSIC)
10-24 DODGE RAM 25-5500 CREW CAB 6.5FT BED (INCL. CHASSIS CAB DIESEL MODELS)

PARTS LIST:

1	Driver/Left Running Board	18	8mm x 30mm Hex Bolts
1	Passenger/Right Running Board	24	8mm x 24mm OD x 2mm Flat Washers
3	Driver Front/Passenger Rear Mounting Brackets	12	8mm Lock Washers
3	Passenger Front/Driver Rear Mounting Brackets	6	8mm Hex Nuts
3	Driver/Left Support Brackets	6	8mm Nylon Lock Nuts
3	Passenger/Right Support Brackets	6	8mm Plastic Retainers
12	10mm x 35mm Hex Bolts	12	6mm x 25mm Hex Bolts
24	10mm x 27mm OD x 3mm Flat Washers	24	6mm x 22mm OD x 2mm Flat Washers
12	10mm Nylon Lock Nuts	12	6mm Nylon Lock Nuts
6	8mm x 30mm Bolt Plates		

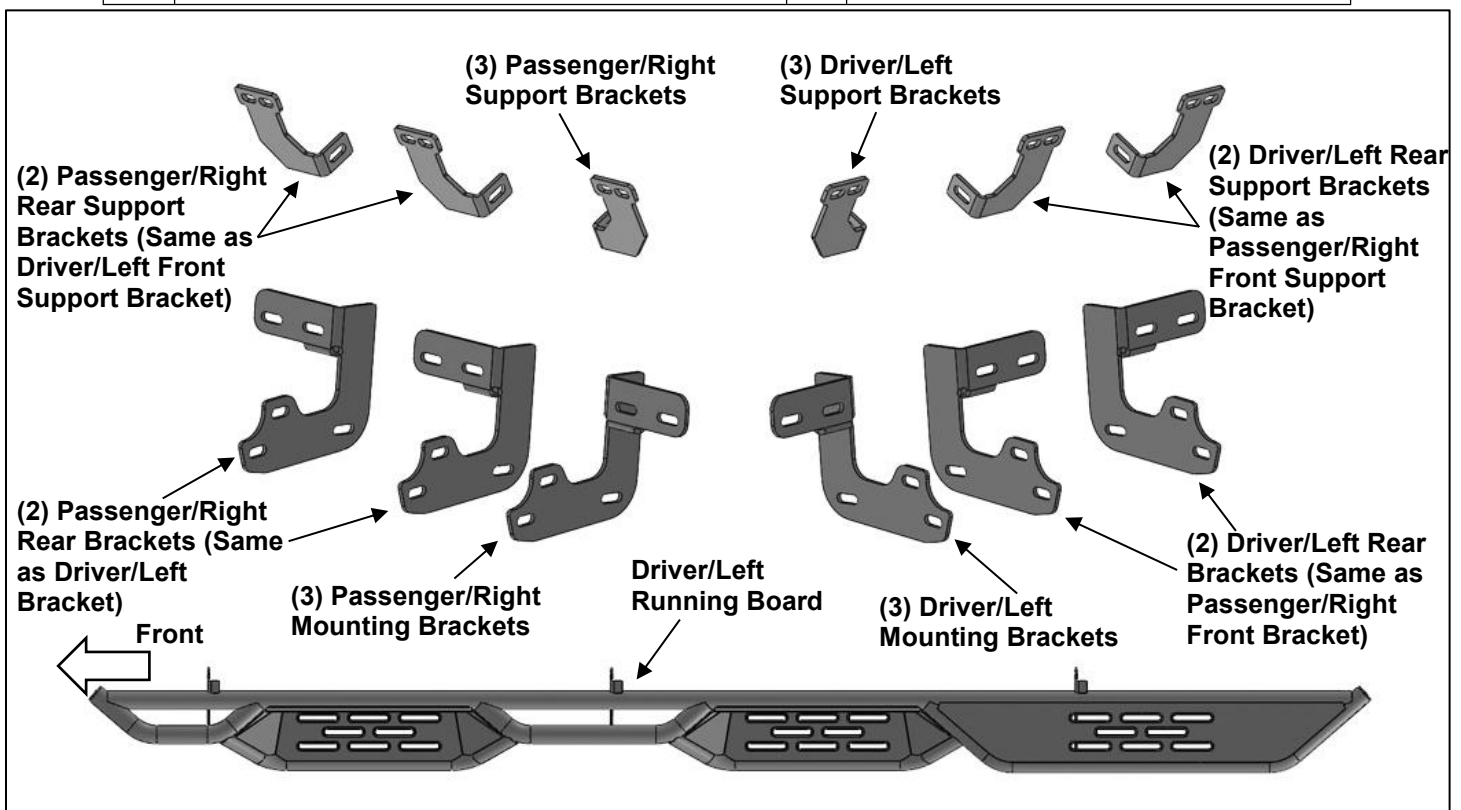

PROCEDURE: REMOVE CONTENTS FROM BOX. VERIFY ALL PARTS ARE PRESENT. READ INSTRUCTIONS CAREFULLY BEFORE STARTING INSTALLATION. DRILLING MAY BE REQUIRED.

- Starting at the driver side-front of the vehicle, remove the sealing tape covering the factory holes in the side of the inner panel, **(Figure 1)**.
- Determine the correct procedure to attach the driver side front Bracket for your model/year:

Models without factory threaded inserts in body panel:

- Select (1) 8mm Bolt/nut Plate, **(Figure 2)**. Partially thread an 8mm Hex Bolt onto the threaded of the Nut Plate, **(Figure 3)**. Thread the Hex Bolt in until it is flush with the welded nut. Use the Hex Bolt as a handle and insert the Bolt and Nut Plate into the oval hole, **(Figure 4)**. Feed the threaded bolt on the Bolt Plate through one of the hex shaped factory holes.
- Thread (1) 8mm Plastic Retainer onto the threaded end and down tight against the body panel, **(Figure 5)**. **NOTE:** The Plastic Retainer is designed to keep the Bolt/Nut Plate from falling into the body panel and to aid in Bracket installation.
- Select (1) Driver/Left Bracket, **(Figure 6)**. Attach the Bracket to the threaded end of the Bolt Plate with (1) 8mm Flat Washer, (1) 8mm Lock washer and (1) 8mm Hex Nut, **(Figure 6)**. **IMPORTANT:** Driver/Left Front Bracket is the same as the Driver/Left Center and Passenger/Right Rear Brackets. Do not tighten hardware at this time.

NB1 WHEEL TO WHEEL RUNNING BOARDS

09-18 DODGE RAM 1500 CREW CAB 6.5FT BED (INCL. 19-24 RAM 1500 CLASSIC)

10-24 DODGE RAM 25-5500 CREW CAB 6.5FT BED (INCL. CHASSIS CAB DIESEL MODELS)

- d. Remove the 8mm Hex Bolt from the nut on the Bolt Plate from **Step 2a**. Rotate the Bolt on the Bolt Plate until the threaded nut lines up with the remaining hole in the Mounting Bracket and body panel, (**Figure 7**). Attach the Bracket to the threaded Nut Plate with (1) 8mm x 30mm Hex Bolt, (1) 8mm Lock Washer and (1) 8mm Flat Washer, (**Figure 7**). Do not tighten hardware.

Models with factory threaded inserts:

- a. Attach (1) Driver/Left Mounting Bracket to the threaded inserts with (2) 8mm x 30mm Hex Bolts, (2) 8mm Lock Washers and (2) 8mm Flat Washer, (**Figures 8 & 9**). Do not tighten hardware.
3. Attach (1) Support Bracket to the back of the pinch weld with (2) 6mm Hex Bolts, (4) 6mm Flat Washers and (2) 6mm Nylon Lock Nuts, (**Figure 10**). Do not fully tighten hardware. **IMPORTANT:** 2009-12 models not equipped with factory holes will require drilling through the pinch weld to fully attach Bracket. Do not drill through pinch weld at this time, (**see Step 8**).
4. Attach the Support Bracket to the Mounting Bracket with (1) 8mm Hex Bolt, (2) 8mm Flat Washers and (1) 8mm Nylon Lock Nut, (**Figure 11**). Do not tighten hardware at this time.
5. Move along the side of the body panel to the center mounting location, (**Figure 12**). Repeat **Steps 1—4** to install (1) Driver/Left Center Mounting Bracket to the center mounting location.
6. Move to the rear location, (**Figure 13**). Repeat **Steps 1—4** to attach (1) Passenger/Right Rear Mounting Bracket to the Driver/Left rear mounting location.
7. Select the Driver/Left Running Board. Attach the Running Board to the rear faces on the Mounting Brackets with (6) 10mm Hex Bolts, (12) 10mm Flat Washers and (6) 10mm Nylon Lock Nuts, (**Figure 14**). Do not tighten hardware.
8. Properly level and adjust the Side Step and fully tighten all hardware.
2009-12 models requiring drilling through pinch trim:
 - a. Level the Side Step to the vehicle. Make sure all (3) Brackets are tight against the bottom of the body panel and tighten all mounting hardware.
 - b. Mark the location of the slots onto the pinch weld.
 - c. Drill (2) 1/4" holes through the pinch weld for each Bracket. **IMPORTANT:** Do not drill too close to the bottom edge of the pinch weld. Drill the holes in the center of the marked slots.
 - d. Repeat **Step 3** to attach the Brackets to the drilled holes in the pinch weld. Check for level then fully tighten all hardware.
9. Repeat **Steps 1—8** to attach the Passenger/Right Sidebar.
10. Do periodic inspections to the installation to make sure that all hardware is secure and tight.

To protect your investment, Do not use any type of polish or wax that may contain abrasives that could damage the finish. Mild soap may be used to clean the Side Steps.

Driver/Left Side Installation Pictured

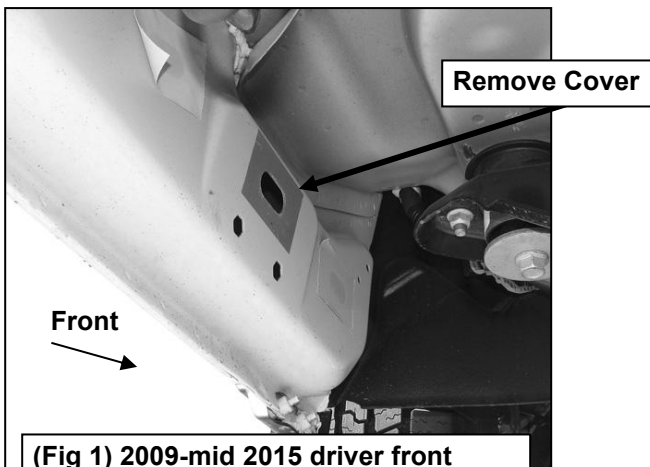

(Fig 1) 2009-mid 2015 driver front mounting location (No factory holes in pinch weld 2009-2012 models)

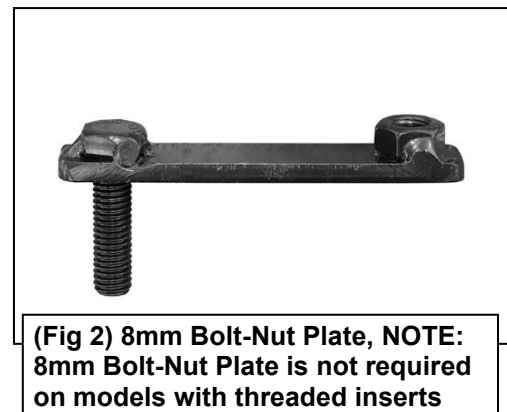

(Fig 2) 8mm Bolt-Nut Plate, NOTE: 8mm Bolt-Nut Plate is not required on models with threaded inserts

NB1 WHEEL TO WHEEL RUNNING BOARDS
09-18 DODGE RAM 1500 CREW CAB 6.5FT BED (INCL. 19-24 RAM 1500 CLASSIC)
10-24 DODGE RAM 25-5500 CREW CAB 6.5FT BED (INCL. CHASSIS CAB DIESEL MODELS)
Driver/Left Side Installation Pictured

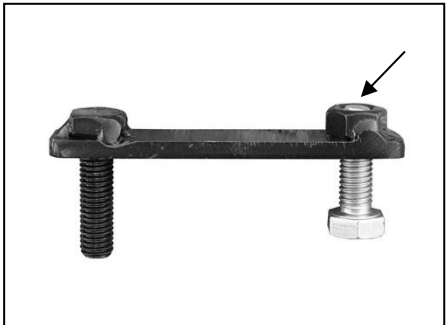

(Fig 3) Thread (1) 8mm Hex Bolt into the nut on the plate. Stop when bolt reaches end of nut as pictured

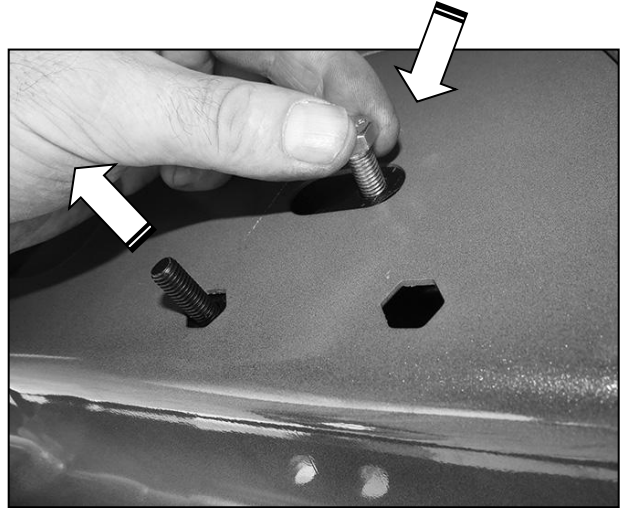

(Fig 4) Use the loose Hex Bolt as a handle. Insert the Bolt Plate into the oval hole and feed the threaded end out either factory hex shaped hole. IMPORTANT: Do not let go of the hex bolt until after Plastic Retainer has been threaded onto bolt (Fig 5)

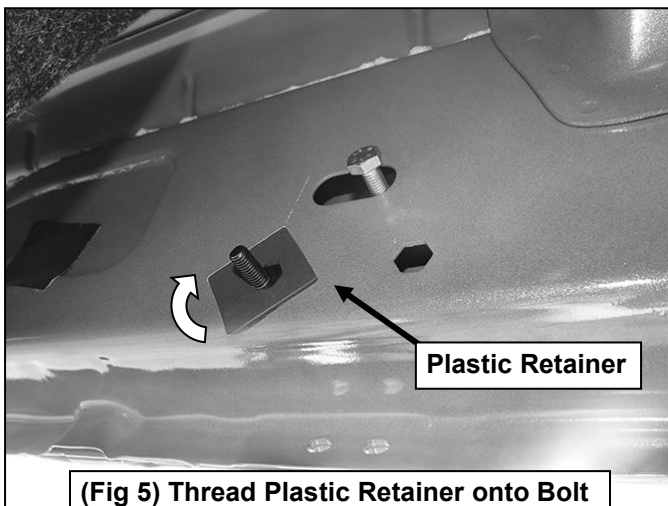

(Fig 5) Thread Plastic Retainer onto Bolt Plate to hold Bolt Plate in position.

**8mm Flat Washer
 8mm Lock Washer
 8mm Hex Nut**

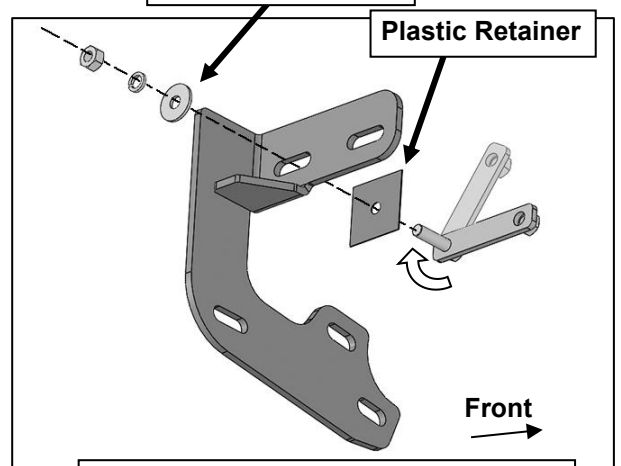

(Fig 6) Remove 8mm Hex Bolt. Rotate Bolt Plate to line up with remaining factory hex shaped hole

**8mm Hex Bolt
 8mm Lock Washer
 8mm Flat Washer**

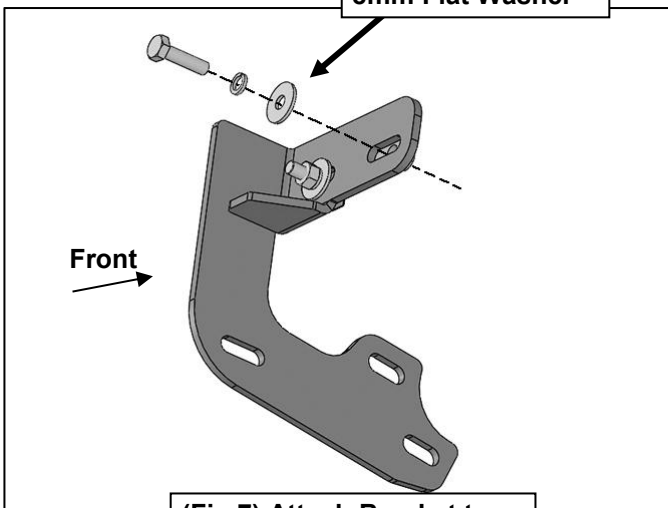

(Fig 7) Attach Bracket to threaded end of Bolt Plate

NB1 WHEEL TO WHEEL RUNNING BOARDS
09-18 DODGE RAM 1500 CREW CAB 6.5FT BED (INCL. 19-24 RAM 1500 CLASSIC)
10-24 DODGE RAM 25-5500 CREW CAB 6.5FT BED (INCL. CHASSIS CAB DIESEL MODELS)
Driver/Left Side Installation Pictured

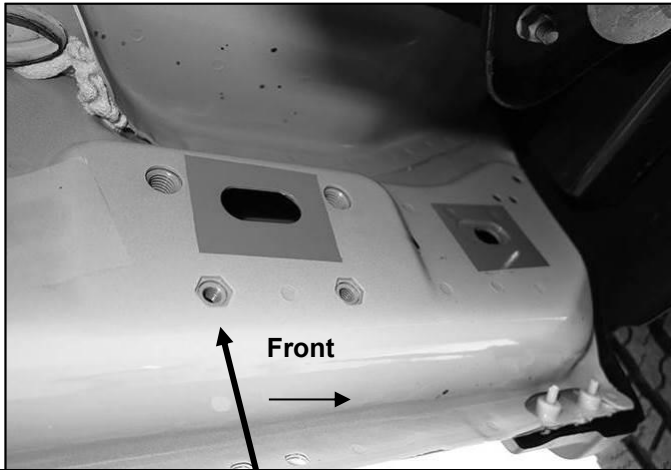

(Fig 8) Driver/left side front mid 2015-on (example of models with factory installed threaded inserts)

IMPORTANT: 2009-2012 models without holes in pinch weld will require drilling 1/4" holes through pinch weld to attach the bracket. Do complete installation of Running Boards first, level Running Board before drilling holes for bracket.

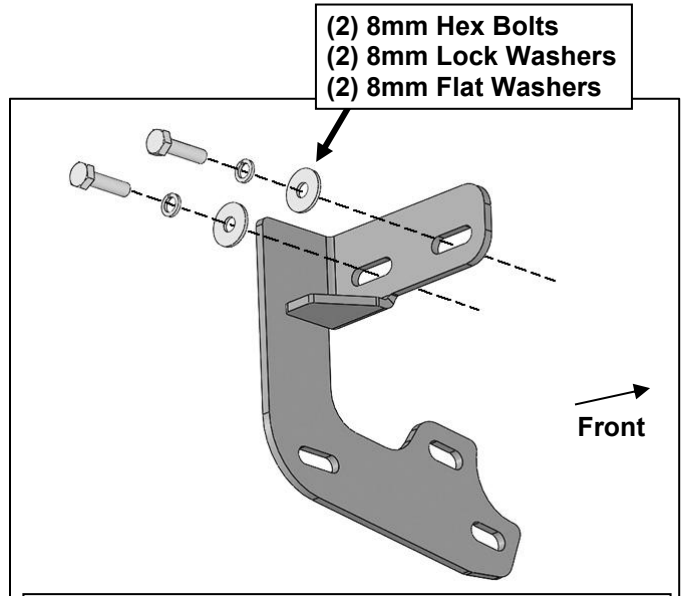

(Fig 9) Driver/left side front models with factory installed threaded inserts. Bolt Plate not required

- (2) 6mm Hex Bolts
- (4) 6mm Flat Washers
- Large Spacer
- (2) 6mm Nylon Lock Nuts

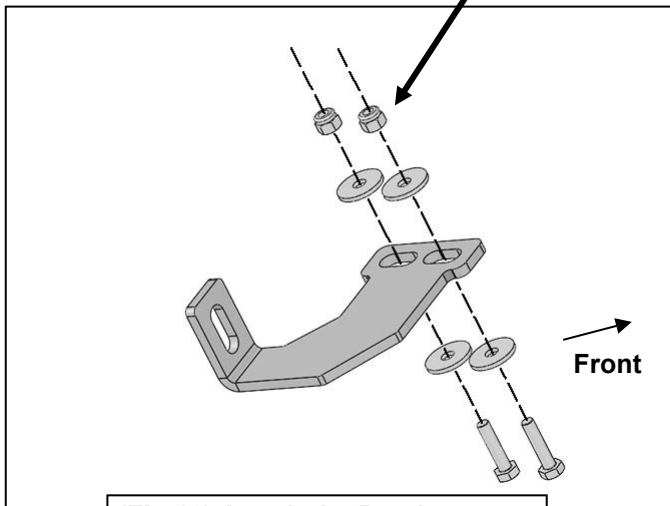

(Fig 10) Attach the Bracket to back of pinch weld (models with factory holes in pinch weld only)

- 8mm Hex Bolt
- (2) 8mm Flat Washers
- 8mm Nylon Lock Nut

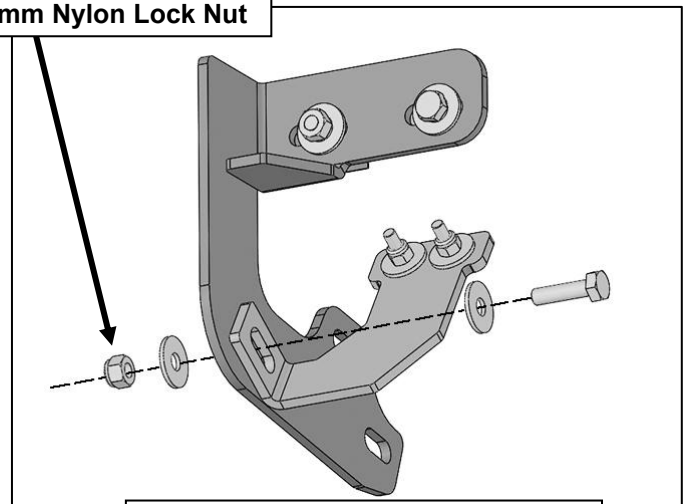

(Fig 11) Attach the Support Bracket to back of pinch weld (models with factory holes in pinch weld only)

NB1 WHEEL TO WHEEL RUNNING BOARDS
09-18 DODGE RAM 1500 CREW CAB 6.5FT BED (INCL. 19-24 RAM 1500 CLASSIC)
10-24 DODGE RAM 25-5500 CREW CAB 6.5FT BED (INCL. CHASSIS CAB DIESEL MODELS)
Driver/Left Side Installation Pictured

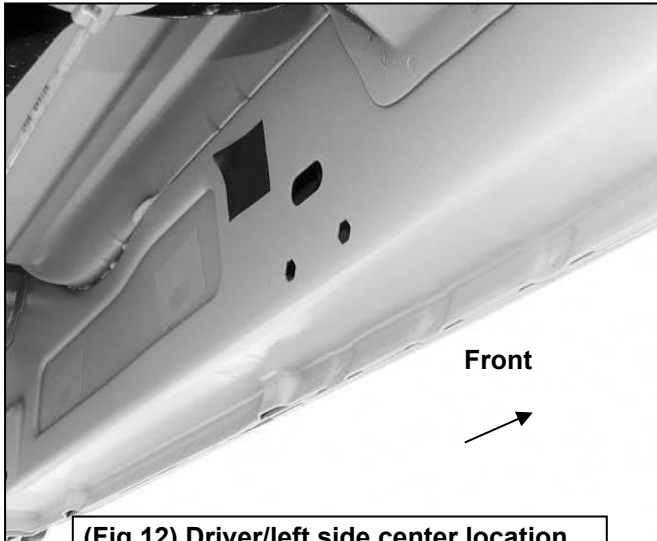

(Fig 12) Driver/left side center location

IMPORTANT: 2009-2012 models without holes in pinch weld will require drilling 1/4" holes through pinch weld to attach the bracket. Do complete installation of Running Boards first, level Running Board before drilling holes for bracket.



(Fig 13) Driver/left rear mounting location

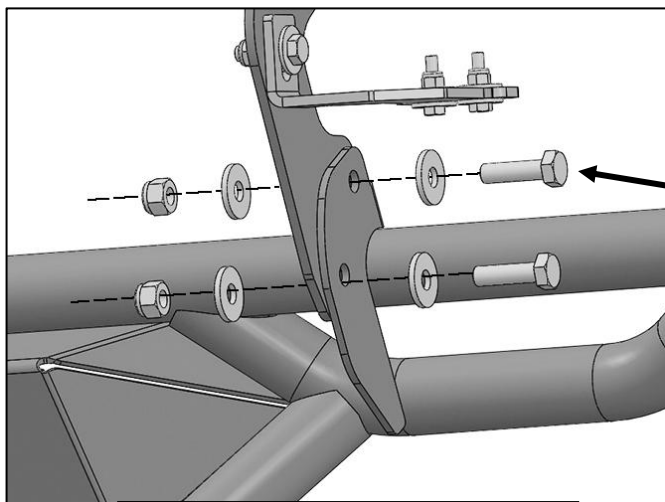

(Fig 14) Attach the Driver/Left Side Step to the (3) Mounting Brackets

- (2) 10mm Hex Bolts**
- (4) 10mm Flat Washers**
- (2) 10mm Nylon Lock Nuts**