

**NB1 WHEEL TO WHEEL RUNNING BOARDS**  
**07-18 1500/ 07-19 25-3500 SILVERADO/SIERRA CREW CAB 5.5FT BED & 6.5FT BED**  
**INCLUDES DIESEL W/DEF**

**PARTS LIST:**

1	Driver/Left NB1 Running Board	32	10mm x 27mm OD x 3mm Flat Washers
1	Passenger/Right NB1 Running Board	14	10mmx 20mm x 2mm Flat Washers
1	Passenger/Right Front Upper Bracket	8	10mm Lock Washers
1	Passenger/Right Front Lower Bracket	8	10mm Hex Nuts
3	Driver/Left Mounting Brackets	16	10mm Nylon Lock Nuts
2	Passenger/Right Mounting Brackets	2	10mm Plastic Retainers
1	Driver/Left Body Bracket	1	8mm Bolt Plate
1	Passenger/Right Body Bracket	1	8mm x 40mm Hex Bolt
2	Rear Mounting Brackets	11	8mm x 25mm Hex Bolts
1	Driver/Left Rear Support Bracket	1	8mm x 28mm OD x 3mm Flat Washer
1	Passenger/Right Rear Support Bracket	12	8mm x 24mm x 2mm Flat Washers
2	10-1.50mm Bolt Plate	11	8mm Lock Washers
16	10mm x 35mm Hex Bolts	1	8mm Nylon Lock Nut
6	10mm x 30mm Hex Bolts	11	8mm Clip-On Nuts

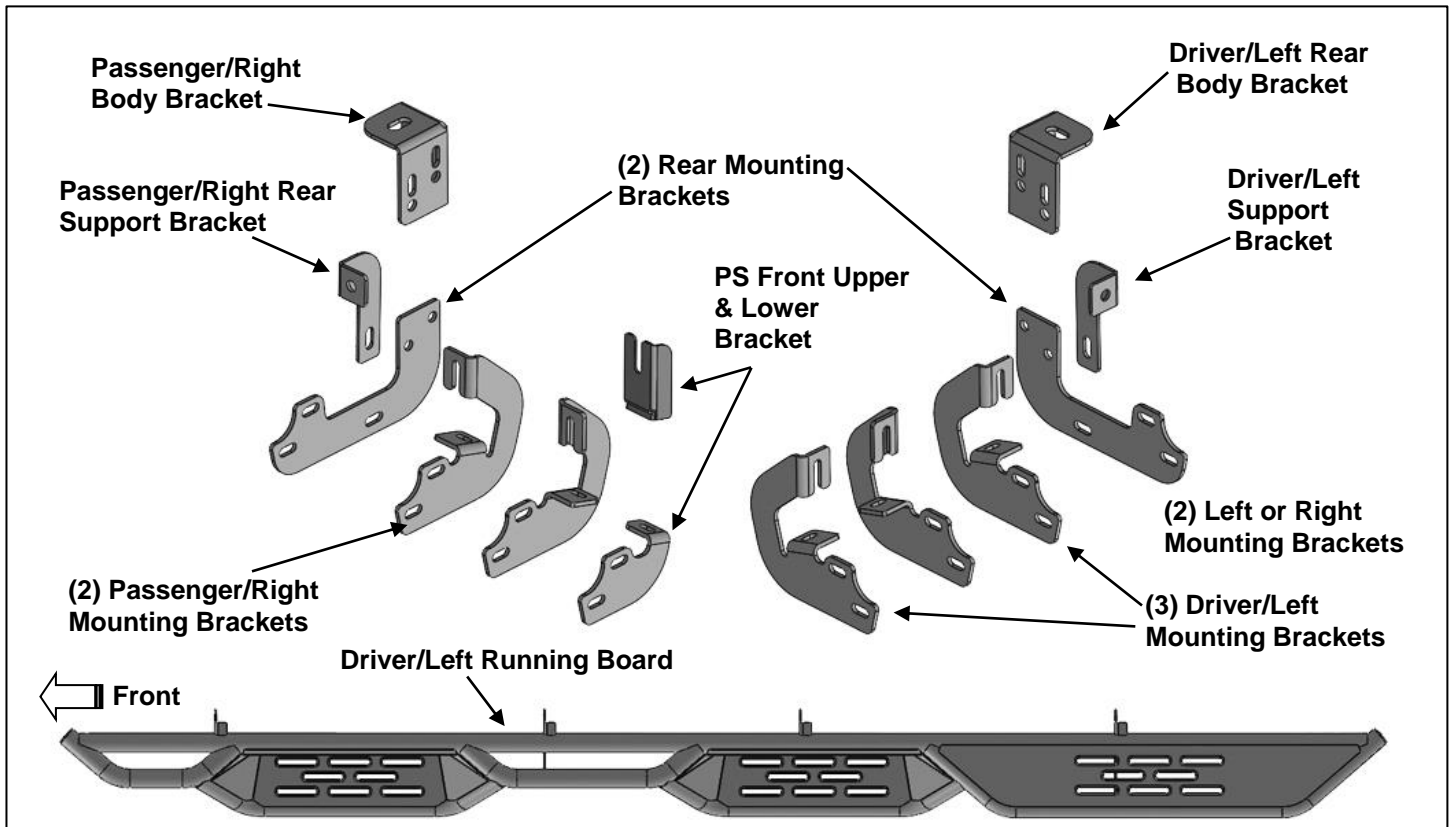

**PROCEDURE: REMOVE CONTENTS FROM BOX. VERIFY ALL PARTS ARE PRESENT. READ INSTRUCTIONS CAREFULLY BEFORE STARTING INSTALLATION. ON MODELS WITH DEF TANK, SELECT A FLAT, LEVEL AREA FOR INSTALLATION. MAY REQUIRE CUTTING.**

1. Start the installation under the Driver/Left side of the vehicle. Locate the 5 tabs along the bottom edge of the body, (pinch weld). Mounting Brackets will bolt to the 1st, 2nd, (just in front of center of cab), 4th mounting tabs and rear mounting hole, **(Figure 1)**. Directly above each tab is a top mounting location on the side of the body panel. Hold a Bracket up in place to help determine the mounting holes to use along the body.
2. Determine the correct procedure for your model year and each Bracket location.  
**Bottom mounting location on the edge of the pinch weld.**

**NB1 WHEEL TO WHEEL RUNNING BOARDS**  
**07-18 1500/ 07-19 25-3500 SILVERADO/SIERRA CREW CAB 5.5FT BED & 6.5FT BED**  
**INCLUDES DIESEL W/DEF**

**Flat tab on pinch weld with factory installed weld nut:**

Thread hex bolt into weld nut from the backside-down to clear paint from threads, **(Figure 2)**.

**Flat tab on pinch weld with hole:**

Select (1) 8mm Clip Nut. Slide the Clip Nut over the tab with the nut facing up behind the tab, **(Figures 3 & 4)**. Line up threaded nut with hole in the tab. Repeat for each mounting location.

**Locate top mounting location on the back side of the body panel.**

**Models with factory installed threaded insert in body panel:**

Thread 8mm Hex Bolt into threaded insert to clear paint as required, **(Figures 2 & 3)**.

**Large and small hole in side of body panel:**

Remove the rubber plug from the larger hole, **(Figure 4)**. Select (1) 8mm Clip Nut. Slide the Clip Nut into the larger hole. Line up the threaded nut with the smaller hole.

3. Select (1) Driver/Passenger Mounting Bracket. Bolt the Mounting Bracket to the Clip Nuts and/or the factory threaded holes with (2) 8mm Hex Bolts, (2) 8mm Lock Washers and (2) 8mm Flat Washers, **(Figures 5 & 6)**. Do not tighten hardware.
4. Repeat **Steps 1—3** to attach the 2nd and 3rd Driver/Left side Brackets.
5. Temporarily remove the factory rear body bolt. Select the Driver/Right Body Bracket. Attach Bracket to the body mount with the factory body bolt, **(Figures 7 & 8)**. Do not tighten hardware.
6. **Determine the procedure for the model year Silverado/Sierra:**
  - a. **2007—2013 1500 & 2007—2014 2500/3500.** Attach Driver/Left Mounting Bracket to lower holes on the Body Mount Bracket with (2) 10mm x 30mm Hex Bolts, (4) 10mm x 20mm Flat Washers, (2) 10mm Lock Washers and (2) 10mm Hex Nuts, **(Figures 9 & 10)**.
  - b. **2014—2018 1500 & 2015—2019 2500/3500.** Attach Driver/Left Mounting Bracket to upper slots in the body Mount Bracket with (2) 10mm Hex Bolts, (4) 10mm Flat Washers, (2) 10mm Lock Washers and (2) 10mm Hex Nuts, **(Figures 9 & 10)**.
7. Remove the plastic plug in the rear mounting location in the rocker panel. Select (1) 10mm Bolt Plate. Insert the plate into the hole in Driver/Left Rear mounting location, **(Figures 11 & 12)**. Thread the Plastic Retainer onto threads until snug, **(Figure 13)**. Select the Driver/Left Support Bracket. Attach Support Bracket to the rocker panel with (1) 10mm Flat Washer, (1) 10mm Lock Washer and (1) 10mm Hex Nut, **(Figure 14)**.
8. Attach the Support Bracket to the front of the Rear Mounting Bracket with (1) 10mm x 30mm Hex Bolt, (2) 10mm x 20mm Flat Washers, (1) 10mm Lock Washer and (1) 10mm Hex Nut, **(Figure 15)**. Do not tighten hardware.
9. Select the Driver/Left NB1 Running Board. Carefully line up the Running Board to the slots in the front faces of the (4) Mounting Brackets. Secure the Running Board to the (4) Brackets with (8) 10mm x 35mm Hex Bolts, (16) 10mm x 27mm Flat Washers and (8) 10mm Nylon Lock Nuts, **(Figures 16 & 17)**. Do not tighten hardware.
10. Level and adjust the Running Board, then fully tighten all hardware.
11. Move to the Passenger/Right side of the vehicle. On the Passenger/Right side, determine if the vehicle is equipped with a plastic diesel exhaust fluid (DEF) tank, **(Figures 18 & 19)**.

**Models without DEF tank, skip to Step 12.**

**Models with DEF tank:** The tank sits close to the side of the body. With specialized tools, the passenger front upper and lower Bracket can be installed but room is very limited.

**Determine model year of vehicle before proceeding.**

**Up to 2016 models:**

It may be easier to drop the tank down to access the inner side of the body panel for upper bracket installation. Tank will not need to be removed, only dropped down for access to mounting location.

**IMPORTANT:** If tank is full, it will be very heavy and assistance is highly recommended to avoid injury or damage to the vehicle or the tank. It is recommended that installation is performed when the DEF tank is low on fluid before dropping the tank.

- a. On models with plastic lower tray under the tank, remove the (3) hex bolts attaching the tray to the frame, **(Figure 18)**, and remove the tray.
- b. Release the tank filler hose. Release the plug for the sending unit on the top of the tank.

**NB1 WHEEL TO WHEEL RUNNING BOARDS  
07-18 1500/ 07-19 25-3500 SILVERADO/SIERRA CREW CAB 5.5FT BED & 6.5FT BED  
INCLUDES DIESEL W/DEF**

- c. Support the tank with a floor jack. Place a smooth flat surface, (wooden block for example), between the floor jack and the tank to avoid damaging the plastic tank. Do not push up on the tank; only support the weight of the tank with the jack.
- d. Remove the (2) bolts securing the tank straps to the vehicle, **(Figure 19)**. Tilt the straps to release from the brackets. Slowly lower the tank until the top of the tank is almost visible. Use blocks or stands to support the tank while installing the front Upper and Lower Brackets.
- e. Proceed to **Step 12**.

**2017 models and on:**

- a. Remove the (4) hex bolts attaching plastic cover to DEF tank, **(Figure 20A)** and remove plastic cover, **(Figure 20B)**. **NOTE:** On 2017-on 2500/3500 models, only remove plastic cover from DEF tank. **Do not lower DEF tank** and proceed to **Step 12**.
- 12.** Locate the first tab on the edge of the pinch weld and insert (1) 8mm Clip Nut into the top hole, **(Figure 21)**. Select the Upper Bracket, **(Figure 22)**. Attach the Upper Bracket to the Clip Nut with (1) 8mm Hex Bolt, (1) 8mm Lock Washer and (1) 8mm Flat Washer, **(Figure 23)**. Do not tighten hardware.
- 13.** Line up the hole in the bottom of the Upper Bracket with the hole in the tab on the pinch weld.
- a. **Models with a weld-nut:** Slide the Bracket over the weld-nut. Attach the Lower Bracket to the bottom of the body and weld-nut with (1) 8mm x 40mm Hex Bolt and (1) 8mm x 28mm Flat Washer, **(Figures 25 & 26)**. Do not tighten hardware.
  - b. **Models with flat tab and hole:** Insert the 8mm Bolt Plate down through the hole in the Upper Bracket and mounting tab, **(Figure 24)**. Attach the Lower Bracket to the bottom of the body and Bolt Plate with (1) 8mm x 24mm Flat Washer and (1) 8mm Nylon Lock Nut, **(Figures 25 & 26)**. Do not tighten hardware.
- 14.** Repeat **Steps 1—3** for the 2nd and 3rd passenger side Bracket installations. **NOTE:** Cradles on Brackets installed on passenger side will face forward.
- a. **2017-on 2500/3500 DEF tank models:** Locate the 2nd tab bracket location along the bottom edge of the body, (pinch weld), **(Figure 21)**. Hold the DEF cover in place and mark the location onto the cover, **(Figures 27A & 27B)**. Use a sharp knife or hacksaw blade to carefully cut a slot in the plastic cover to clear the 2nd Bracket. Remove as little plastic as possible.
- 15.** Repeat **Steps 7 & 8** to attach Passenger/Right Rear Brackets.
- 16.** Repeat **Steps 9 & 10** to attach the Passenger/Right NB1 Running Board.
- 17.** Once the Running Board has been installed and all hardware fully tightened, reinstall the DEF tank and cover, if equipped, as described in **Step 11**.
- 18.** Do periodic inspections to the installation to make sure that all hardware is secure and tight.

**To protect your investment,** Do not use any type of polish or wax that may contain abrasives that could damage the finish. Mild soap may be used also to clean the Running Boards.

NB1 WHEEL TO WHEEL RUNNING BOARDS  
07-18 1500/ 07-19 25-3500 SILVERADO/SIERRA CREW CAB 5.5FT BED & 6.5FT BED  
INCLUDES DIESEL W/DEF

Driver/Left Side Installation Pictured

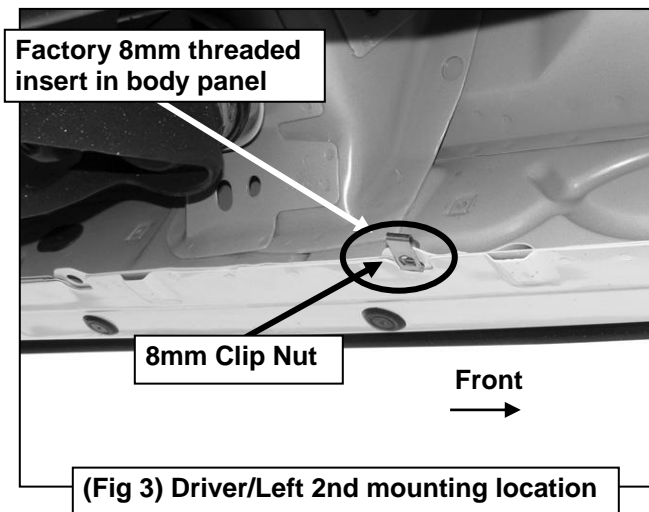
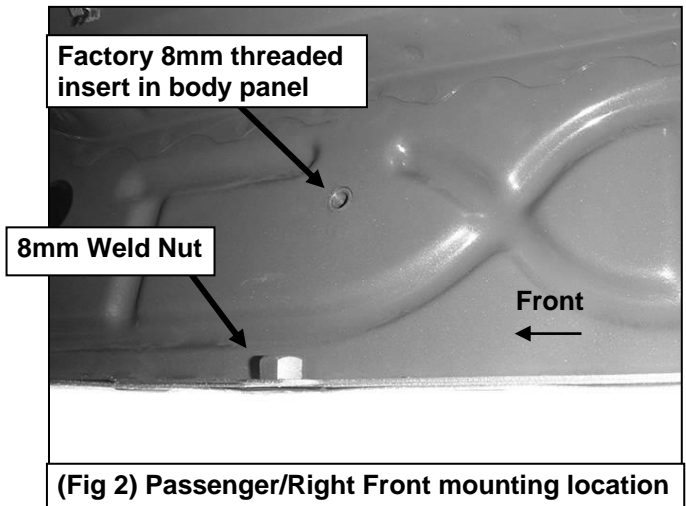
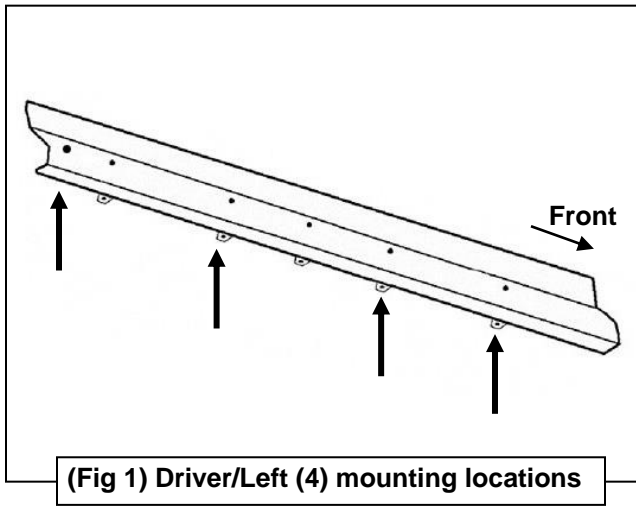

NB1 WHEEL TO WHEEL RUNNING BOARDS  
07-18 1500/ 07-19 25-3500 SILVERADO/SIERRA CREW CAB 5.5FT BED & 6.5FT BED  
INCLUDES DIESEL W/DEF

Driver/Left Side Installation Pictured

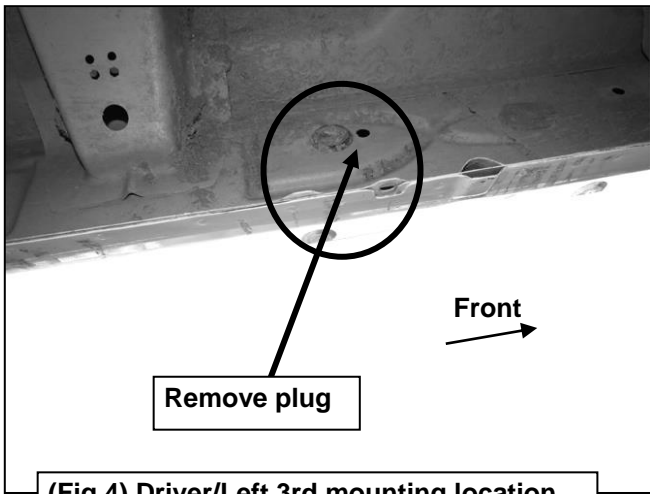

(Fig 4) Driver/Left 3rd mounting location

- (2) 8mm x 25mm Hex Bolts
- (2) 8mm Lock Washers
- (2) 8mm Flat Washers

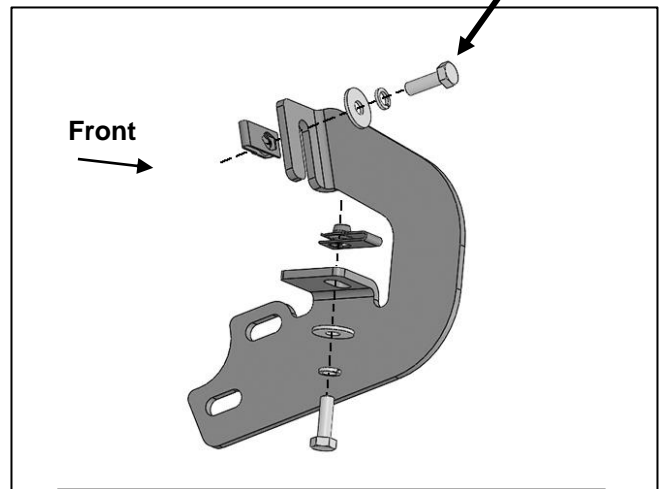

(Fig 5) Driver/Left Front bracket installed

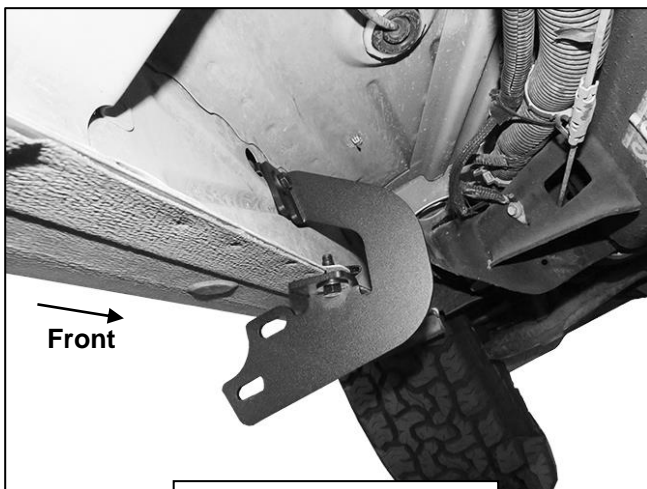

(Fig 6) Driver/Left Front Bracket attached

**NB1 WHEEL TO WHEEL RUNNING BOARDS  
 07-18 1500/ 07-19 25-3500 SILVERADO/SIERRA CREW CAB 5.5FT BED & 6.5FT BED  
 INCLUDES DIESEL W/DEF**

**Driver/Left Side Installation Pictured**

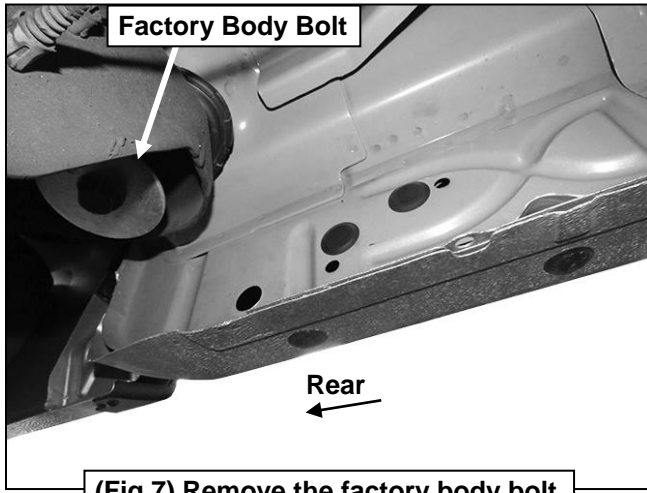

**(Fig 7) Remove the factory body bolt**

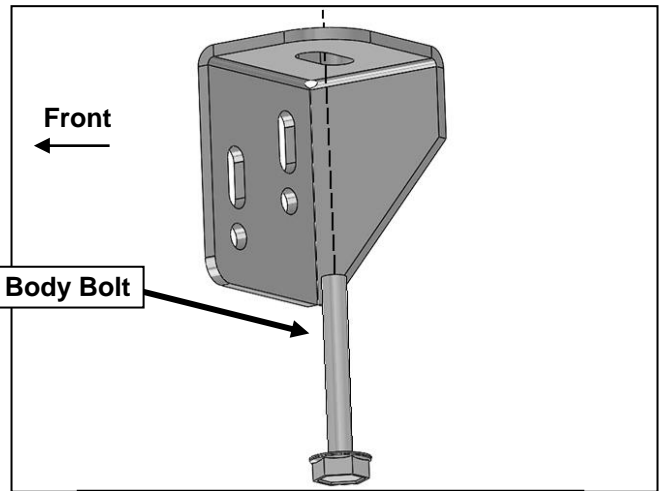

**(Fig 8) Factory Body Bolt installation**

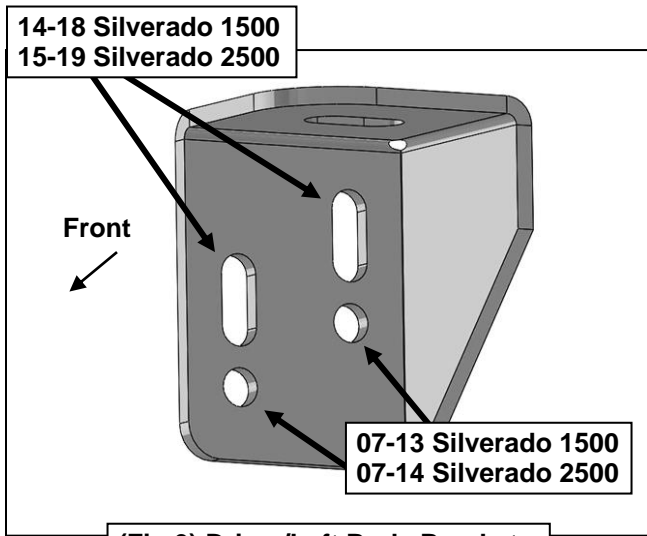

**(Fig 9) Driver/Left Body Bracket**

- (2) 10mm x 30mm Hex Bolts
- (4) 10mm x 20mm Flat Washers
- (2) 10mm Lock Washers
- (2) 10mm Hex Nuts

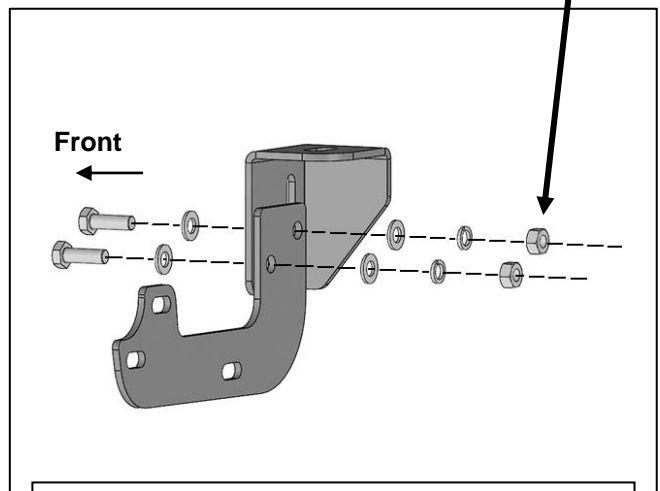

**(Fig 10) Driver/Left Mount Bracket installation**

NB1 WHEEL TO WHEEL RUNNING BOARDS  
07-18 1500/ 07-19 25-3500 SILVERADO/SIERRA CREW CAB 5.5FT BED & 6.5FT BED  
INCLUDES DIESEL W/DEF

Driver/Left Side Installation Pictured

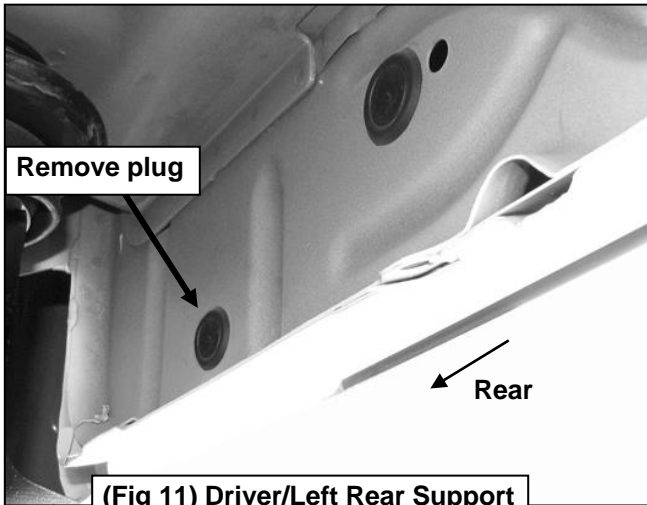

(Fig 11) Driver/Left Rear Support Bracket mounting location

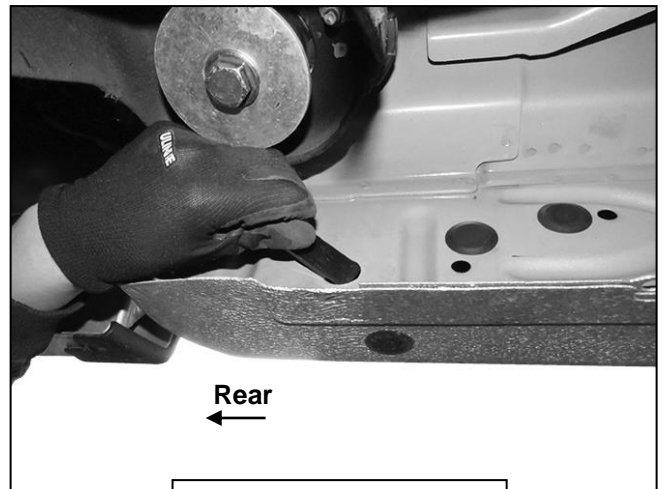

(Fig 12) Insert Bolt Plate



(Fig 13) Bolt Plate and Plastic Retainer installed

- 10mm Bolt Plate
- 10mm Plastic Retainer
- 10mm x 20mm Flat Washer
- 10mm Lock Washer
- 10mm Hex Nut

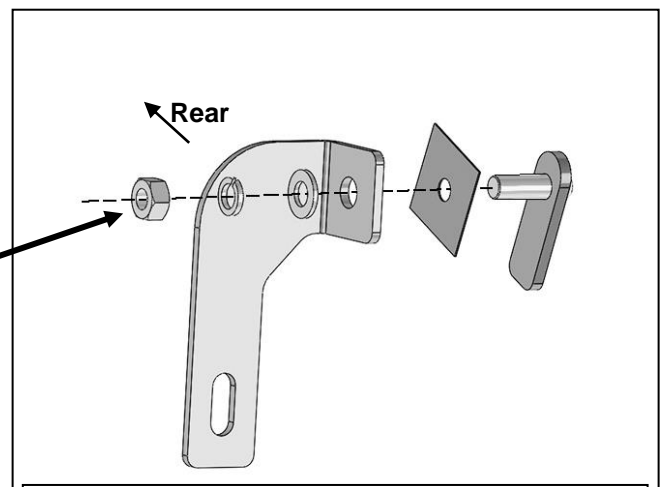

(Fig 14) Driver/Left Support Bracket installation

NB1 WHEEL TO WHEEL RUNNING BOARDS  
07-18 1500/ 07-19 25-3500 SILVERADO/SIERRA CREW CAB 5.5FT BED & 6.5FT BED  
INCLUDES DIESEL W/DEF

Driver/Left Side Installation Pictured

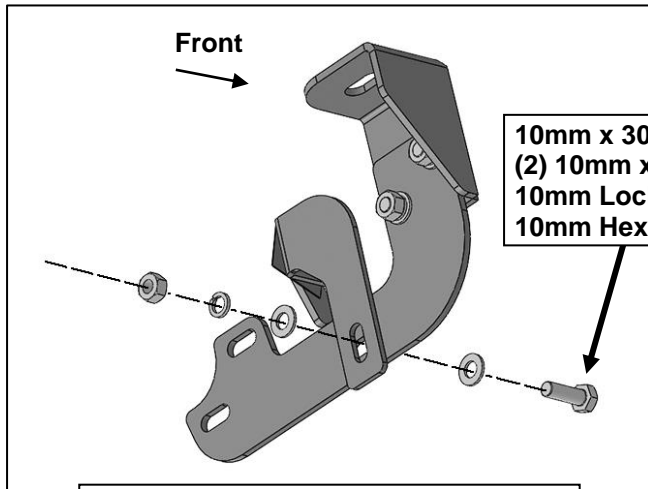

10mm x 30mm Hex Bolt  
(2) 10mm x 20mm Flat Washers  
10mm Lock Washer  
10mm Hex Nut

(Fig 15) Driver/Left Support Bracket  
installation to Rear Mounting Bracket

(2) 10mm x 35mm Hex Bolts  
(4) 10mm x 27mm Flat Washer  
(2) 10mm Nylon Lock Nuts

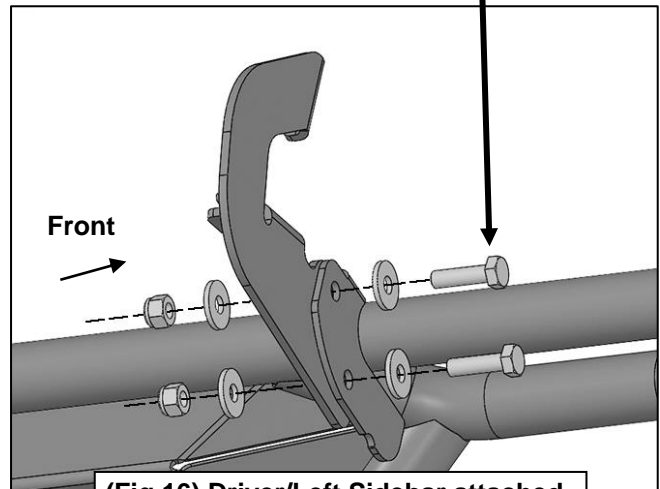

(Fig 16) Driver/Left Sidebar attached  
to Front Bracket illustrated

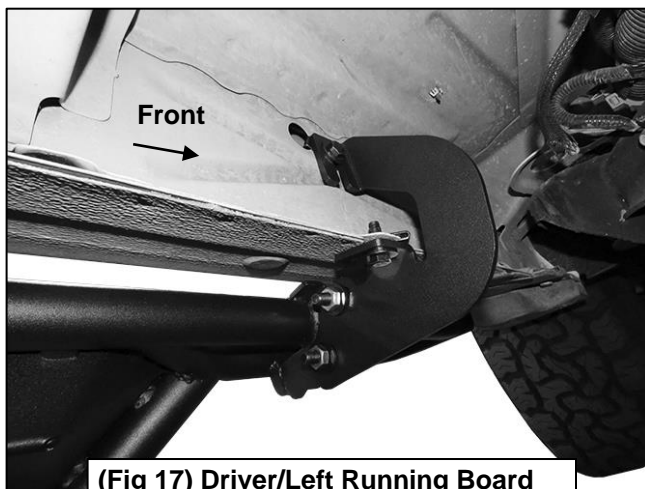

(Fig 17) Driver/Left Running Board  
attached to Driver/Left Front Bracket



NB1 WHEEL TO WHEEL RUNNING BOARDS  
07-18 1500/ 07-19 25-3500 SILVERADO/SIERRA CREW CAB 5.5FT BED & 6.5FT BED  
INCLUDES DIESEL W/DEF

Passenger/Right Side Installation Pictured

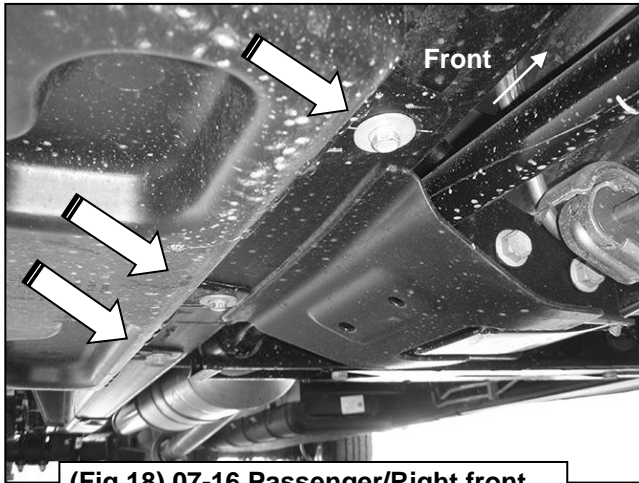

(Fig 18) 07-16 Passenger/Right front pictured with DEF tank cover. Remove (3) hex bolts to remove cover

Remove (2) factory bolts to remove tank straps

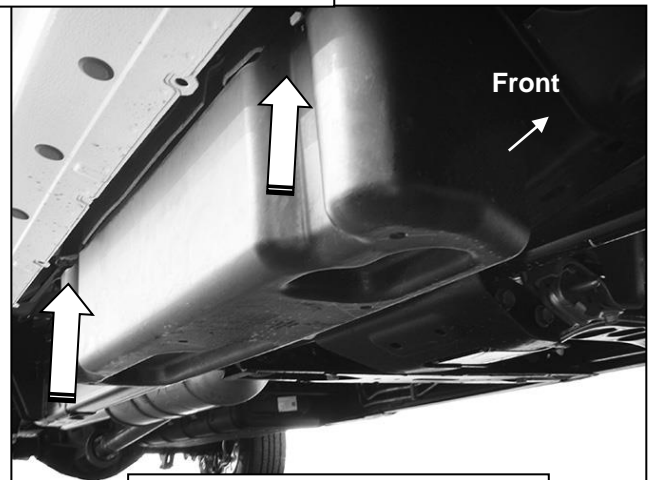

(Fig 19) 07-16 Passenger/Right DEF tank and cover

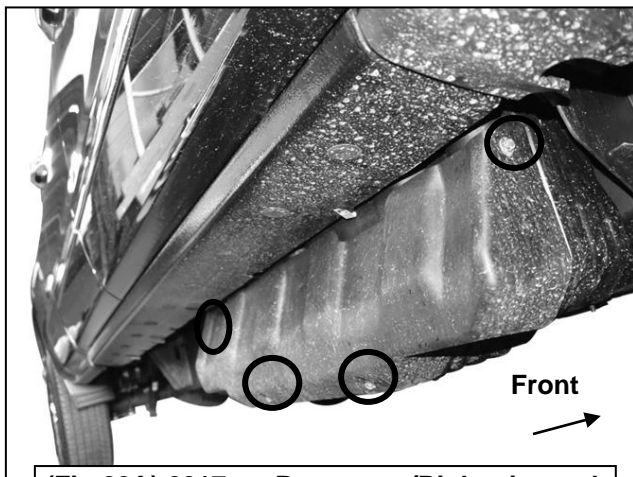

(Fig 20A) 2017-on Passenger/Right pictured with DEF plastic tank cover. Remove (4) hex bolts to remove plastic cover

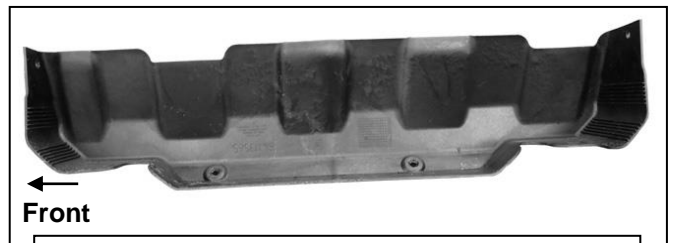

(Fig 20B) 2017-on Passenger/Right DEF cover

NB1 WHEEL TO WHEEL RUNNING BOARDS  
07-18 1500/ 07-19 25-3500 SILVERADO/SIERRA CREW CAB 5.5FT BED & 6.5FT BED  
INCLUDES DIESEL W/DEF

Passenger/Right side Installation Pictured

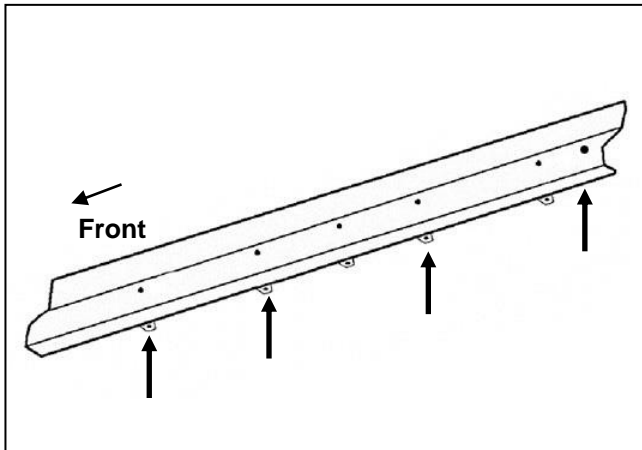

(Fig 21) Passenger/Right Front, 2nd, 3rd and Rear bracket location from back of body panel

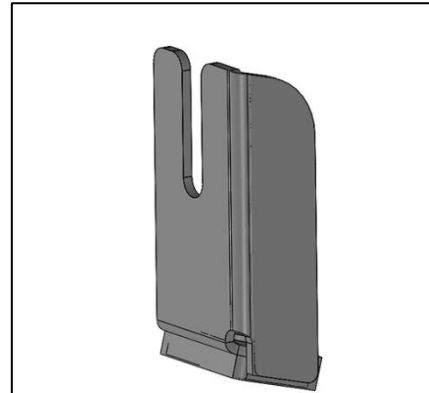

(Fig 22) Passenger/Right Front Upper Bracket (all models)

8mm x 25mm Hex Bolt  
8mm Lock Washer  
8mm Flat Washer

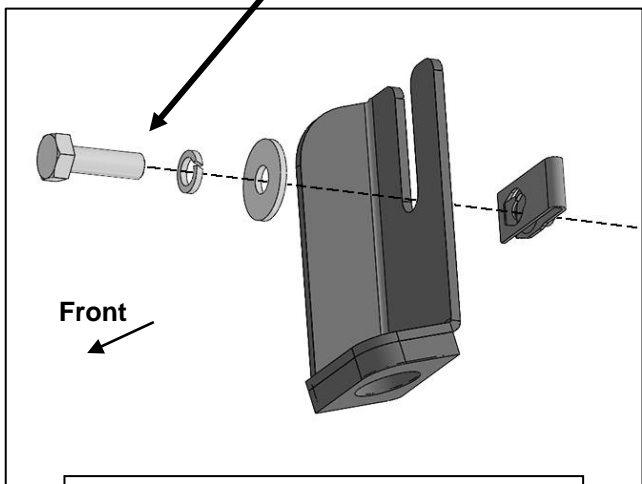

(Fig 23) Slide Upper Bracket over weld nut if equipped-also see Figure 2



(Fig 24) 8mm x 35mm Bolt Plate

**NB1 WHEEL TO WHEEL RUNNING BOARDS  
07-18 1500/ 07-19 25-3500 SILVERADO/SIERRA CREW CAB 5.5FT BED & 6.5FT BED  
INCLUDES DIESEL W/DEF**

**Passenger/Right side Installation Pictured**

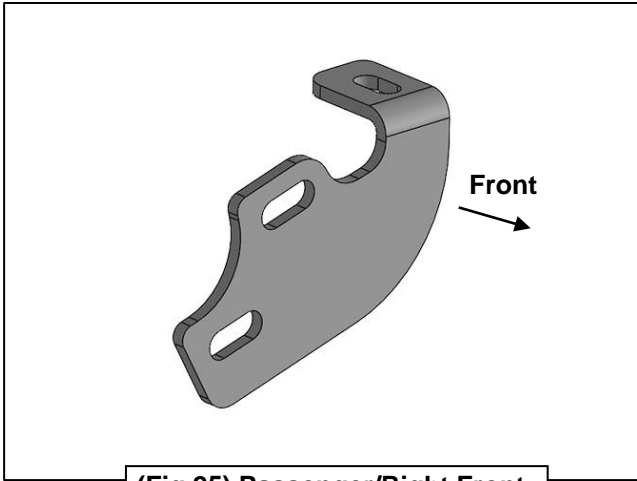

**(Fig 25) Passenger/Right Front Lower Bracket (all models)**

On models with flat tab and 8mm Bolt Plate (see Fig. 21) use:  
8mm Flat Washer  
8mm Nylon Lock Nut  
to attach Lower Bracket to Bolt Plate

Models with weld nut on tab (see Fig. 2) use:  
8mm x 40mm Hex Bolt  
8mm x 28mm Flat Washer

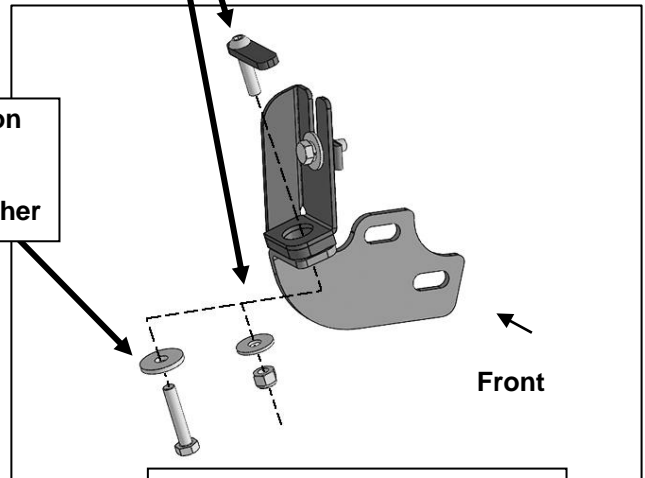

**(Fig 26) Passenger/Right front Bracket installation**



**(Fig 27A) 2017-on DEF tank Mark for cut is approximately 70mm x 10mm**



**(Fig 27B) 2017-on Passenger DEF cut for example only**