

PARTS LIST:

1	Driver/Left Running Board	1	8-1.25mm x 40mm Hex Bolt
1	Passenger/Right Running Board	7	8-1.25mm x 25mm Hex Bolts
2	Driver/Left Mounting Brackets	1	8mm Bolt Plate
1	Passenger/Right Front Upper Bracket	1	8mm x 28mm x 3mm Flat Washer
1	Passenger/Right Front Lower Bracket	8	8mm x 24mm x 2mm Flat Washers
1	Passenger/Right Rear Mounting Bracket	7	8mm Lock Washers
8	10-1.5mm x 35mm Hex Bolts	1	8mm Nylon Lock Nut
16	10mm x 27mm x 3mm Flat Washers	7	8mm Clip Nuts
8	10mm Nylon Lock Nuts		

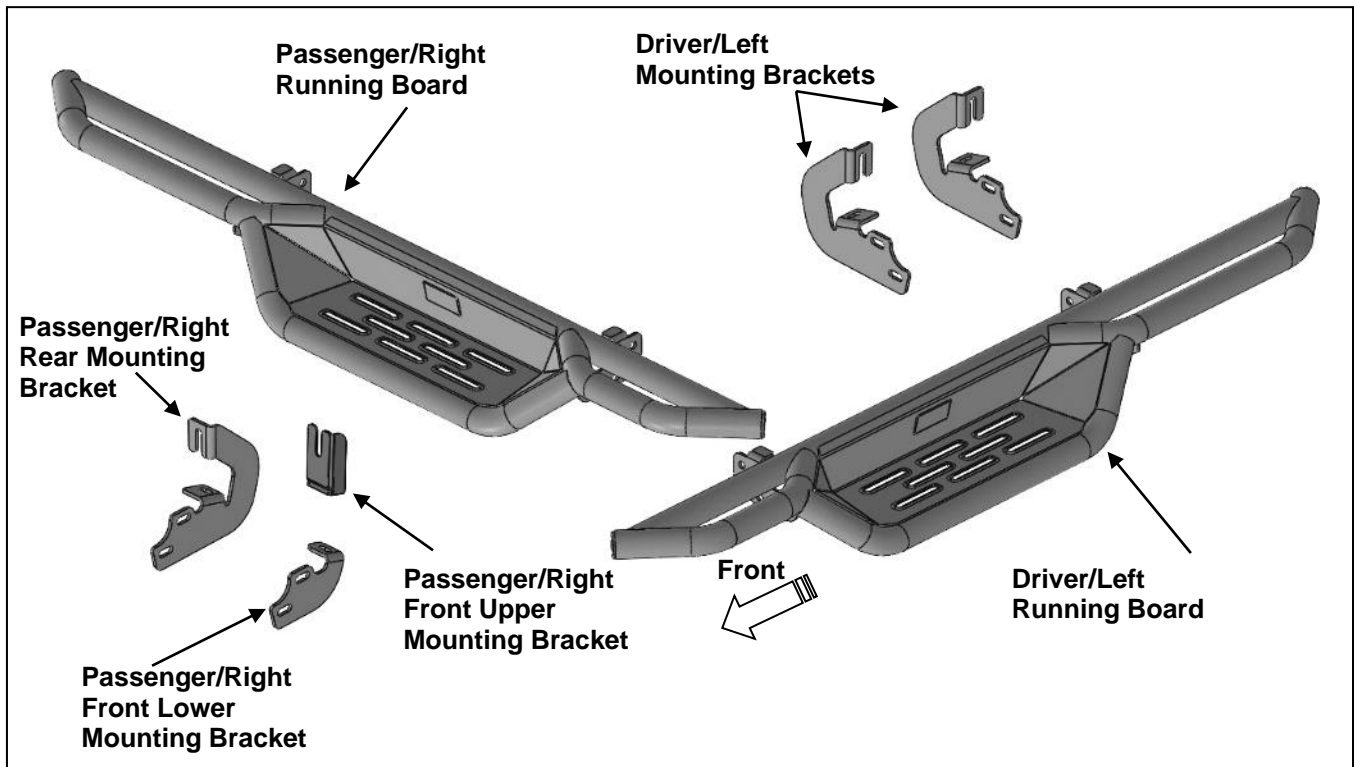

PROCEDURE:

REMOVE CONTENTS FROM BOX. VERIFY ALL PARTS ARE PRESENT. READ INSTRUCTIONS CAREFULLY BEFORE STARTING INSTALLATION. ASSISTANCE IS RECOMMENDED. ON MODELS WITH DEF TANK, SELECT A FLAT, LEVEL AREA FOR INSTALLATION. MAY REQUIRE CUTTING.

1. Start the installation under the Driver/Left side of the vehicle. Locate the mounting tabs along the bottom edge of the body, (pinch weld). Mounting brackets will bolt to both mounting tabs. Directly above each tab is a top mounting location on the side of the body panel. If necessary, line up (1) Driver/Left Mounting Bracket with the mounting holes in the body panel to help determine correct locations, **(Figures 1 & 3).**

2. Determine the correct procedure for your model year and each Bracket location.

Bottom mounting location on the edge of the pinch weld.

Flat tab on pinch weld with factory installed weld nut:

Thread hex bolt into weld nut from the backside-down to clear paint from threads, **(Figure 2).**

Flat tab on pinch weld with hole:

Select (1) 8mm Clip Nut. Slide the Clip Nut over the tab with the nut facing up behind the tab.

Repeat this **Step** for Driver/Left Rear mounting location.

Locate top mounting location on the back side of the body panel.

Models with factory installed threaded insert in body panel:

Thread 8mm Hex Bolt into threaded insert to clear paint as required, (**Figures 2 & 3**).

Large and small holes inside of the body panel:

Remove the rubber plug from the larger hole. Select (1) 8mm Clip Nut. Insert the Clip Nut into the larger hole with the threads facing in.

3. Select (1) Driver/Left Mounting Bracket. Attach bracket to the front mounting location with (2) 8mm x 25mm Hex Bolts, (2) 8mm Lock Washers and (2) 8mm Flat Washers, (**Figures 4—6**). Do not tighten hardware. Repeat this **Step** to attach (1) Driver/Left Mounting Bracket to the rear mounting location.
4. Select the Driver/Left Running Board. Attach the Running Board to the front of the mounting brackets with (4) 10mm Hex Bolts, (8) 10mm Flat Washers and (4) 10mm Nylon Lock Nuts, (**Figures 7—9**).
5. Level and adjust the Running Board and fully tighten all hardware.
6. Move to the passenger side of the vehicle. On the Passenger/Right, determine if the vehicle is equipped with a plastic diesel exhaust fluid (DEF) tank, (**Figures 10 & 11**).
7. **Determine the model/year:**

Models without DEF tank, skip to Step 8.

Models with DEF tank: The tank sits close to the side of the body. With specialized tools, the passenger front upper and lower Bracket can be installed but room is limited.

For 2007—2016 models:

It may be easier to drop the tank down to access the inner side of the body panel for upper bracket installation. Tank will not need to be removed, only dropped down for access to mounting location.

IMPORTANT: If tank is full, it will be very heavy and assistance is highly recommended to avoid injury or damage to the vehicle or the tank. It is recommended that installation is performed when the DEF tank is low on fluid before dropping the tank.

- a. For models with plastic lower tray under the tank, remove the (3) hex bolts attaching the tray to the frame, (**Figure 10**), and remove tray.
- b. Release the tank filler hose. Release the plug for the sending unit on the top of the tank.
- c. Support the tank with a floor jack. Place a smooth flat surface, (wooden block for example), between the floor jack and the tank to avoid damaging the plastic tank. Do not push up on the tank; only support the weight of the tank with the jack.
- d. Remove the (2) bolts securing the tank straps to the vehicle, (**Figure 11**). Tilt the straps to release from the brackets. Slowly lower the tank until the top of the tank is almost visible. Use blocks or stands to support the tank while installing the front Upper and Lower Brackets.
- e. Proceed to **Step 8**.

For 2017—on models:

Remove the (4) hex bolts attaching the plastic cover to DEF tank, (**Figures 12A & 12B**) and remove plastic cover. **Important: Do not remove tank.**

8. Locate the front tab on the edge of the pinch weld on the Passenger/Right side. Repeat **Step 2** to attach 8mm Clip Nuts to the rocker panel.
9. Select the Passenger/Right Upper Mounting Bracket, (**Figure 13**).
 - a. **For models with threaded upper mounting holes.** Attach the upper mounting bracket to the rocker panel with (1) 8mm x 25mm Hex Bolt, (1) 8mm Lock Washer and (1) 8mm x 24mm Flat Washer, (**Figure 14**).
 - b. **For models with holes in the rocker panel.** Attach the upper mounting bracket to the rocker panel with (1) 8mm x 25mm Hex Bolt, (1) 8mm Lock Washer and (1) 8mm x 24mm Flat Washer, (**Figure 14**).
10. Select the Passenger/Right Lower Mounting Bracket.

Models with a weld-nut on the Pinch Weld:

- a. Attach the bracket to the pinch weld with (1) 8mm x 40mm Hex Bolt, (1) 8mm x 24mm Flat Washer, (1) 8mm x 28mm Flat Washer and (1) 8mm Nylon Lock Nut, (**Figure 17**).
- b. Repeat **Steps 2—3** to attach the Passenger/Right Rear Mounting Bracket to the Passenger/Right rear mounting location.

Models with flat tab and hole in the Pinch Weld:

- a. Attach the bracket to the pinch weld with (1) 8mm Bolt Plate, (1) 8mm x 24mm Flat Washer and (1) 8mm Nylon Lock Nut, (**Figures 15 & 16**).

- b. Repeat **Steps 2—3** to attach the Passenger/Right Rear Mounting Bracket to the Passenger/Right rear mounting location.
11. Select the Passenger/Right Running Board. Attach Running Board mounting tabs to the front faces of the mounting brackets with (4) 10mm Hex Bolts, (8) 10mm Flat Washers and (4) 10mm Nylon Lock Nuts, **(Figure 18)**.
 12. **2017-on 2500/3500 DEF tank models:** Locate the rear mounting location along the bottom edge of the body, (pinch weld). Hold the DEF cover in place and mark the rear bracket location onto the cover, **(Figure 19)**. Use a sharp knife or hacksaw blade to carefully cut a slot in the plastic cover to clear the Rear Bracket, **(Figure 20)**. Remove as little plastic as possible.
 13. Level and adjust the Running Board and fully tighten all hardware.
 14. Once fully installed and all hardware fully tightened, reinstall the DEF tank and cover, if equipped, as described in **Steps 6 & 7**.
 15. Do periodic inspections to the installation to make sure that all hardware is secure and tight.
- To protect your investment,** Do not use any type of polish or wax that may contain abrasives that could damage the finish. Mild soap may be used also to clean the Running Board.

Driver/Left Side Installation Pictured

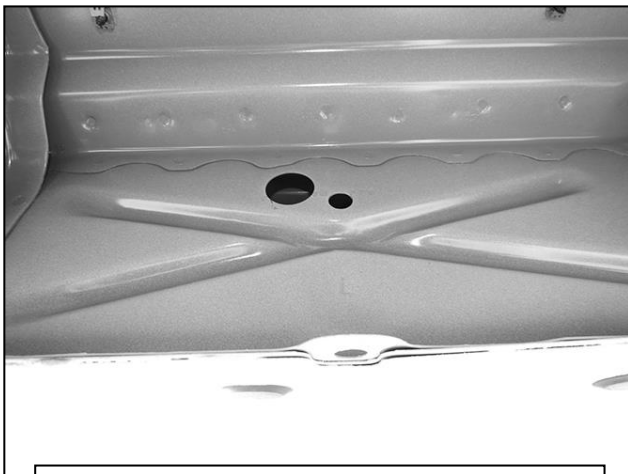

(Fig 1) Driver/Left Front mounting location

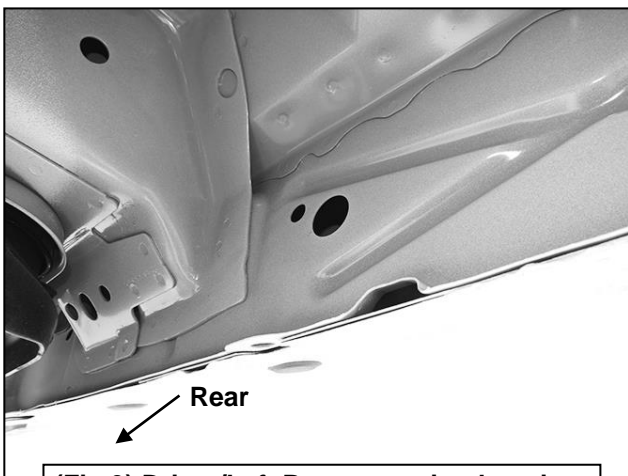

(Fig 3) Driver/Left Rear mounting location

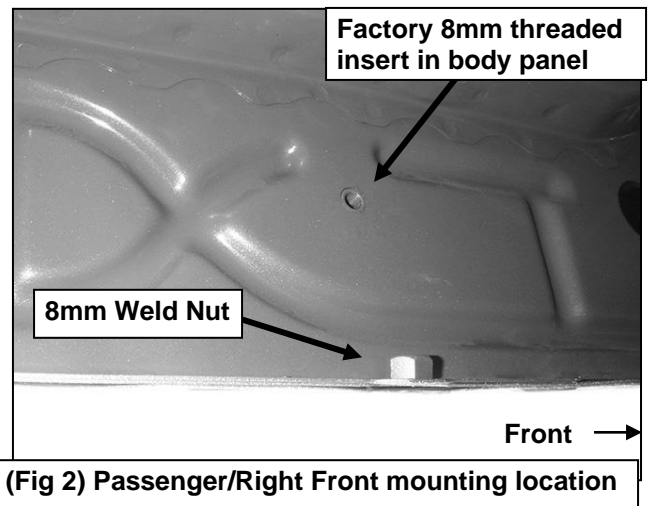

(Fig 2) Passenger/Right Front mounting location

Driver/Left Side Installation Pictured

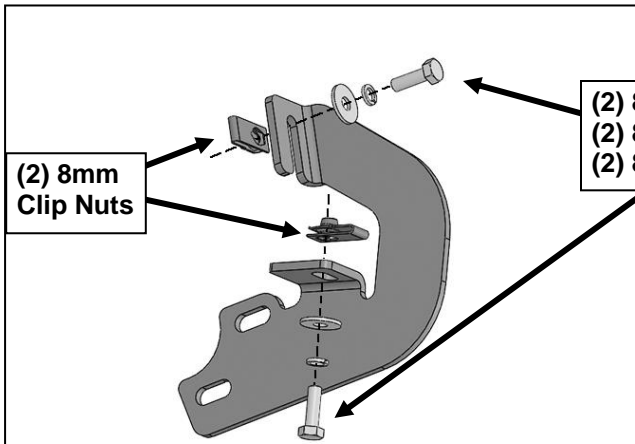

(2) 8mm
Clip Nuts

(2) 8mm x 25mm Hex Bolts
(2) 8mm Lock Washers
(2) 8mm Flat Washers

(Fig 4) Driver/Left Mounting Brackets installation

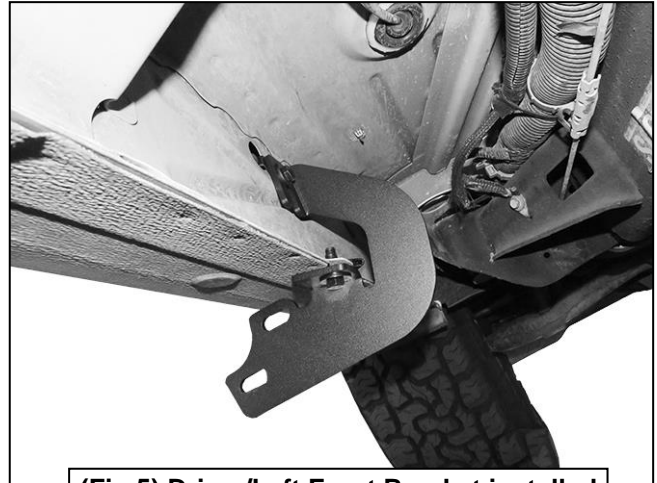

(Fig 5) Driver/Left Front Bracket installed

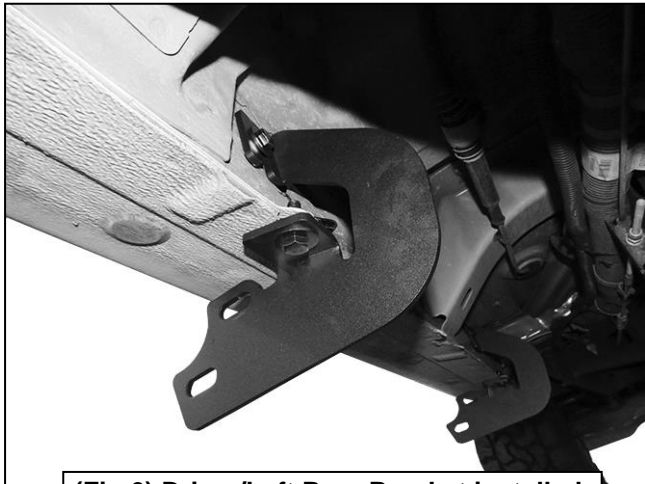

(Fig 6) Driver/Left Rear Bracket installed

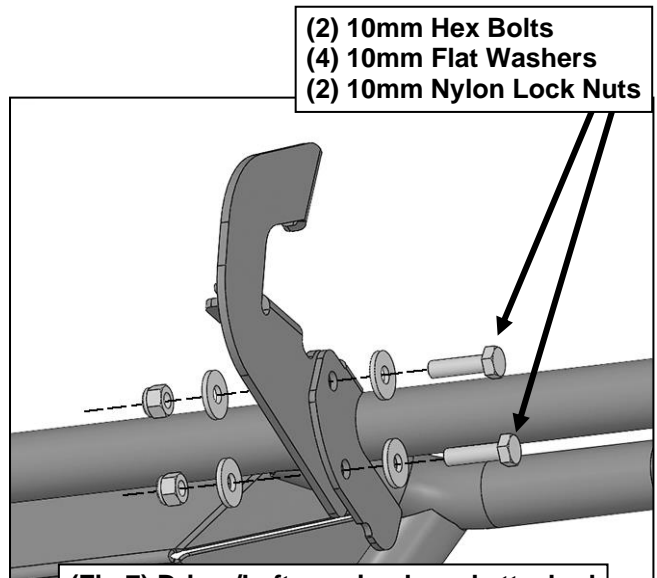

(2) 10mm Hex Bolts
(4) 10mm Flat Washers
(2) 10mm Nylon Lock Nuts

(Fig 7) Driver/Left running board attached to front face of front mounting bracket



(Fig 8) Driver/Left running board attached to front face of front mounting bracket

Driver/Left Side Installation Pictured

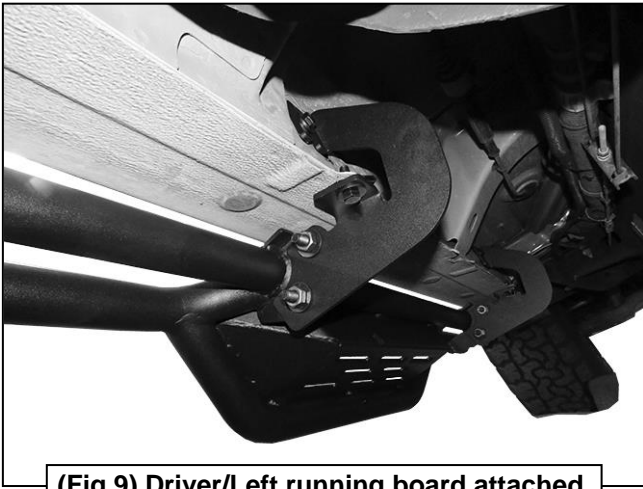

(Fig 9) Driver/Left running board attached to front face of Rear mounting bracket

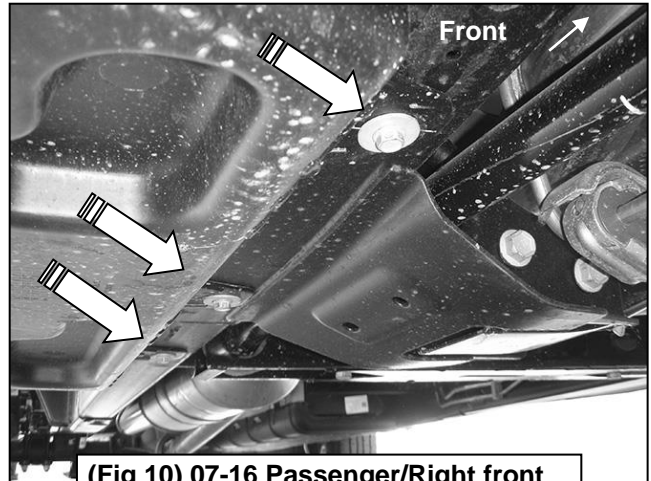

(Fig 10) 07-16 Passenger/Right front pictured with DEF tank cover. Remove (3) hex bolts to remove cover



Remove (2) factory bolts to remove tank straps

(Fig 11) Passenger side 07-16 DEF tank and cover

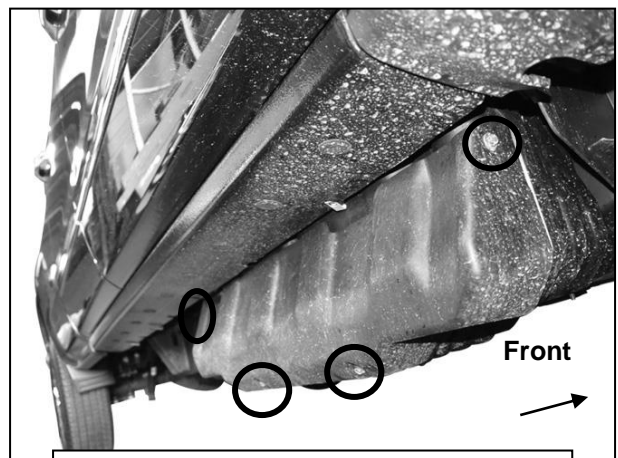

(Fig 12A) 2017-on Passenger side pictured with DEF plastic tank cover. Remove (4) hex bolts to remove plastic

Passenger/Right Side Installation Pictured



(Fig 12B) 2017-on Passenger side DEF cover removed

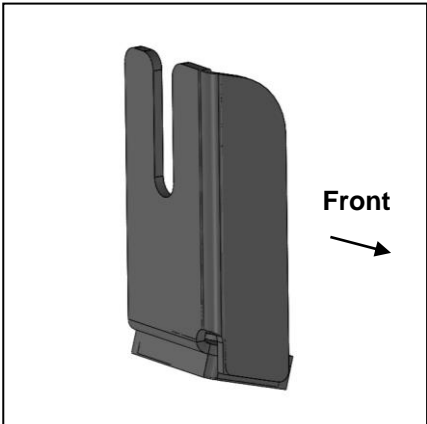

(Fig 13) Passenger/Right Front Upper Bracket (all models)

**8mmx 25mm Hex Bolt
8mm Lock Washer
8mm Flat Washer**

8mm Clip Nut (not required with threaded holes in rocker panel)

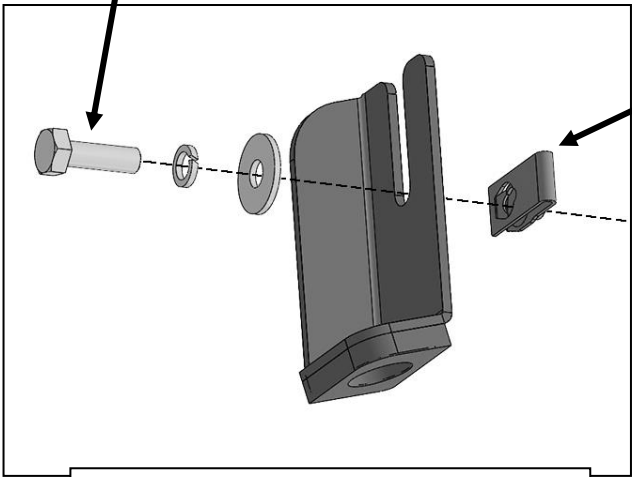

(Fig 14) Passenger/Right Front Upper Bracket installation to the rocker panel



(Fig 15) 8mm x 35mm Bolt Plate

Passenger/Right Side Installation Pictured

