

**NB1 WHEEL TO WHEEL RUNNING BOARDS**  
**07-18 1500 SILVERADO/SIERRA EXTENDED/DOUBLE CAB 6 1/2FT BED**  
**INCLUDES 19-21 SILVERADO 1500 LD & 19-21 SIERRA 1500 LIMITED**  
**07-19 25-3500 SILVERADO/SIERRA EXTENDED/DOUBLE CAB 6 1/2FT BED**  
**INCLUDES DIESEL W/DEF**

**PARTS LIST:**

1	Driver/Left NB1 Running Board	32	10mm x 27mm OD x 3mm Flat Washers
1	Passenger/Right NB1 Running Board	14	10mmx 20mm x 2mm Flat Washers
1	Passenger/Right Front Upper Bracket	8	10mm Lock Washers
1	Passenger/Right Front Lower Bracket	8	10mm Hex Nuts
3	Driver/Left Mounting Brackets	16	10mm Nylon Lock Nuts
2	Passenger/Right Mounting Brackets	2	10mm Plastic Retainers
1	Driver/Left Body Bracket	1	8mm Bolt Plate
1	Passenger/Right Body Bracket	1	8mm x 40mm Hex Bolt
2	Rear Mounting Brackets	12	8mm x 25mm Hex Bolts
1	Driver/Left Rear Support Bracket	1	8mm x 28mm OD x 3mm Flat Washer
1	Passenger/Right Rear Support Bracket	13	8mm x 24mm x 2mm Flat Washers
2	10-1.50mm Bolt Plate	12	8mm Lock Washers
16	10mm x 35mm Hex Bolts	1	8mm Nylon Lock Nut
6	10mm x 30mm Hex Bolts	11	8mm Clip-On Nuts

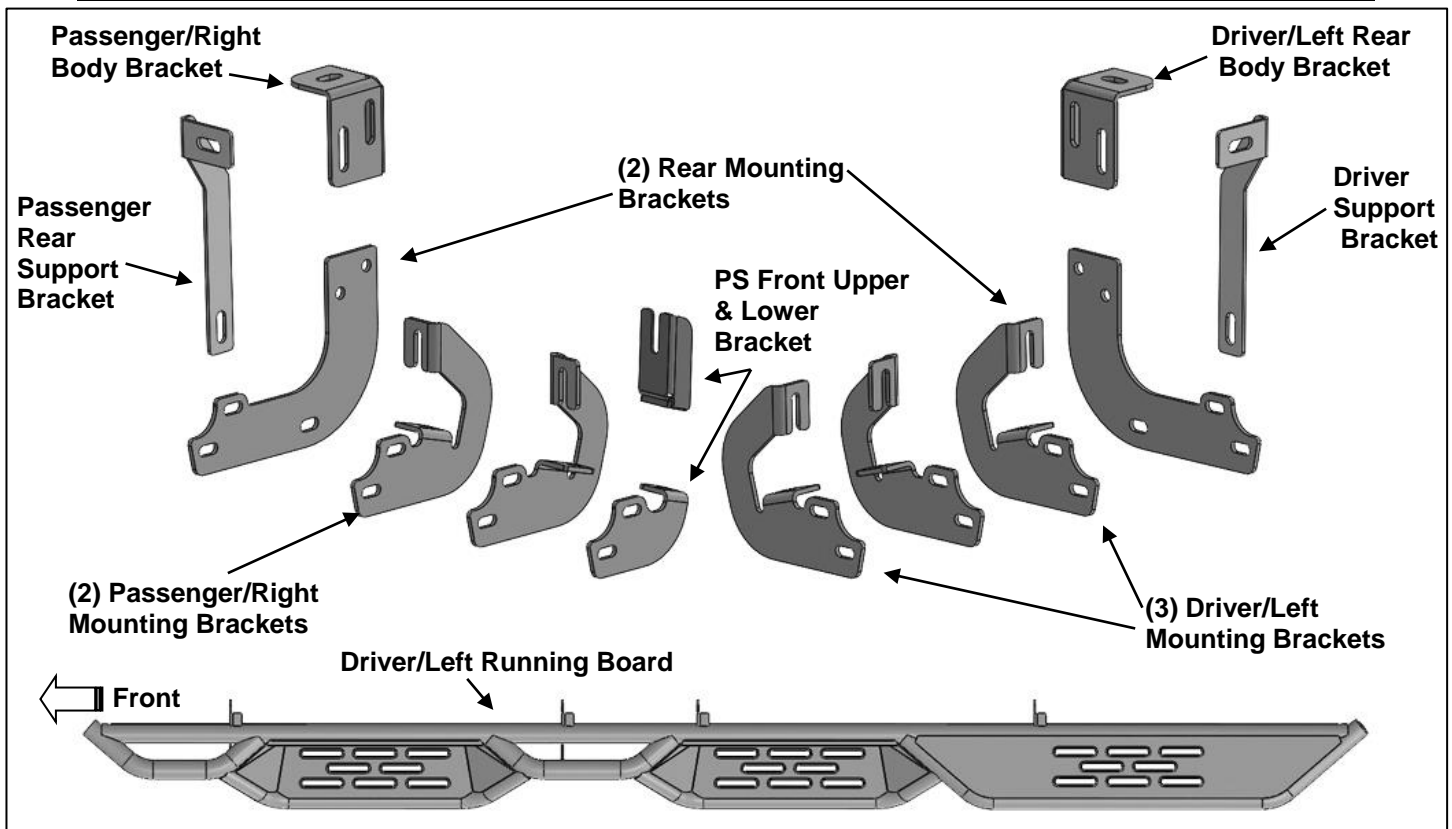

**PROCEDURE: REMOVE CONTENTS FROM BOX. VERIFY ALL PARTS ARE PRESENT. READ INSTRUCTIONS CAREFULLY BEFORE STARTING INSTALLATION. ON MODELS WITH DEF TANK, SELECT A FLAT, LEVEL AREA FOR INSTALLATION. MAY REQUIRE CUTTING.**

1. Start the installation under the Driver/Left side of the vehicle. Locate the 4 tabs along the bottom edge of the body, (pinch weld). Mounting Brackets will bolt to the 1st, 2nd, (just in front of center of cab), 3rd mounting tabs and rear mounting hole, **(Figure 1)**. Directly above each tab is a top mounting location on the side of the body panel. Hold a Bracket up in place to help determine the mounting holes to use along the body.

**NB1 WHEEL TO WHEEL RUNNING BOARDS  
07-18 1500 SILVERADO/SIERRA EXTENDED/DOUBLE CAB 6 1/2FT BED  
INCLUDES 19-21 SILVERADO 1500 LD & 19-21 SIERRA 1500 LIMITED  
07-19 25-3500 SILVERADO/SIERRA EXTENDED/DOUBLE CAB 6 1/2FT BED  
INCLUDES DIESEL W/DEF**

2. Determine the correct procedure for your model year and each Bracket location.

**Bottom mounting location on the edge of the pinch weld.**

**Flat tab on pinch weld with factory installed weld nut:**

Thread hex bolt into weld nut from the backside-down to clear paint from threads, **(Figure 2)**.

**Flat tab on pinch weld with hole:**

Select (1) 8mm Clip Nut. Slide the Clip Nut over the tab with the nut facing up behind the tab, **(Figures 3 & 4)**. Line up threaded nut with hole in the tab. Repeat for each mounting location.

**Locate top mounting location on the back side of the body panel.**

**Models with factory installed threaded insert in body panel:**

Thread 8mm Hex Bolt into threaded insert to clear paint as required, **(Figures 2 & 3)**.

**Large and small hole in side of body panel:**

Remove the rubber plug from the larger hole, **(Figure 4)**. Select (1) 8mm Clip Nut. Slide the Clip Nut into the larger hole. Line up the threaded nut with the smaller hole.

3. Select (1) Driver/Passenger Mounting Bracket. Bolt the Mounting Bracket to the Clip Nuts and/or the factory threaded holes with (2) 8mm Hex Bolts, (2) 8mm Lock Washers and (2) 8mm Flat Washers, **(Figures 5 & 6)**. Do not tighten hardware.
4. Repeat **Steps 1—3** to attach the 2nd and 3rd Driver/Left side Brackets.
5. Temporarily remove the factory rear body bolt. Select the Driver/Right Body Bracket. Attach Bracket to the body mount with the factory body bolt, **(Figures 7 & 8)**. Do not tighten hardware.
6. **Determine the procedure for the model year Silverado/Sierra:**
- a. **2007—2013 1500 & 2007—2014 2500/3500.** Attach Driver/Left Mounting Bracket to lower holes on the Body Mount Bracket with (2) 10mm x 30mm Hex Bolts, (4) 10mm x 20mm Flat Washers, (2) 10mm Lock Washers and (2) 10mm Hex Nuts, **(Figures 9 & 10)**.
  - b. **2014—2018 1500 & 2015—2019 2500/3500.** Attach Driver/Left Mounting Bracket to upper slots in the body Mount Bracket with (2) 10mm Hex Bolts, (4) 10mm Flat Washers, (2) 10mm Lock Washers and (2) 10mm Hex Nuts, **(Figures 9 & 10)**.
7. Remove the cover over the rear mounting location in the rocker panel. Select (1) 10mm Bolt Plate. Insert the plate into the hole in Driver/Left Rear mounting location. Thread the Plastic Retainer onto threads until snug. Select the Driver/Left Support Bracket. Attach Support Bracket to the rocker panel with (1) 10mm Flat Washer, (1) 10mm Lock Washer and (1) 10mm Hex Nut, **(Figure 12)**.
8. Attach the Support Bracket to the front of the Rear Mounting Bracket with (1) 10mm x 30mm Hex Bolt, (2) 10mm x 20mm Flat Washers, (1) 10mm Lock Washer and (1) 10mm Hex Nut, **(Figure 13)**. Do not tighten hardware.
9. Select the Driver/Left NB1 Running Board. Carefully line up the Running Board to the slots in the front faces of the (4) Mounting Brackets. Secure the Running Board to the (4) Brackets with (8) 10mm x 35mm Hex Bolts, (16) 10mm x 27mm Flat Washers and (8) 10mm Nylon Lock Nuts, **(Figures 14 & 15)**. Do not tighten hardware.
10. Level and adjust the Running Board, then fully tighten all hardware.
11. Move to the Passenger/Right side of the vehicle. On the Passenger/Right side, determine if the vehicle is equipped with a plastic diesel exhaust fluid (DEF) tank, **(Figures 16 & 17)**.

**Models without DEF tank, skip to Step 12.**

**Models with DEF tank:** The tank sits close to the side of the body. With specialized tools, the passenger front upper and lower Bracket can be installed but room is very limited.

**Determine model year of vehicle before proceeding.**

**Up to 2016 models:**

It may be easier to drop the tank down to access the inner side of the body panel for upper bracket installation. Tank will not need to be removed, only dropped down for access to mounting location.

**IMPORTANT:** If tank is full, it will be very heavy and assistance is highly recommended to avoid injury or damage to the vehicle or the tank. It is recommended that installation is performed when the DEF tank is low on fluid before dropping the tank.

**NB1 WHEEL TO WHEEL RUNNING BOARDS**  
**07-18 1500 SILVERADO/SIERRA EXTENDED/DOUBLE CAB 6 1/2FT BED**  
**INCLUDES 19-21 SILVERADO 1500 LD & 19-21 SIERRA 1500 LIMITED**  
**07-19 25-3500 SILVERADO/SIERRA EXTENDED/DOUBLE CAB 6 1/2FT BED**  
**INCLUDES DIESEL W/DEF**

- a. On models with plastic lower tray under the tank, remove the (3) hex bolts attaching the tray to the frame, **(Figure 16)**, and remove the tray.
- b. Release the tank filler hose. Release the plug for the sending unit on the top of the tank.
- c. Support the tank with a floor jack. Place a smooth flat surface, (wooden block for example), between the floor jack and the tank to avoid damaging the plastic tank. Do not push up on the tank; only support the weight of the tank with the jack.
- d. Remove the (2) bolts securing the tank straps to the vehicle, **(Figure 17)**. Tilt the straps to release from the brackets. Slowly lower the tank until the top of the tank is almost visible. Use blocks or stands to support the tank while installing the front Upper and Lower Brackets.
- e. Proceed to **Step 12**.

**2017 models and on:**

- a. Remove the (4) hex bolts attaching plastic cover to DEF tank, **(Figure 18A)** and remove plastic cover, **(Figure 18B)**. **NOTE:** On 2017-on 2500/3500 models, only remove plastic cover from DEF tank. **Do not lower DEF tank** and proceed to **Step 12**.
12. Locate the first tab on the edge of the pinch weld and insert (1) 8mm Clip Nut into the top hole, **(Figure 21)**. Select the Upper Bracket, **(Figure 19)**. Attach the Upper Bracket to the Clip Nut with (1) 8mm Hex Bolt, (1) 8mm Lock Washer and (1) 8mm Flat Washer, **(Figure 20)**. Do not tighten hardware.
13. Line up the hole in the bottom of the Upper Bracket with the hole in the tab on the pinch weld.
  - a. **Models with a weld-nut:** Slide the Bracket over the weld-nut. Attach the Lower Bracket to the bottom of the body and weld-nut with (1) 8mm x 40mm Hex Bolt and (1) 8mm x 28mm Flat Washer, **(Figures 22 & 23)**. Do not tighten hardware.
  - b. **Models with flat tab and hole:** Insert the 8mm Bolt Plate down through the hole in the Upper Bracket and mounting tab, **(Figure 21)**. Attach the Lower Bracket to the bottom of the body and Bolt Plate with (1) 8mm x 24mm Flat Washer and (1) 8mm Nylon Lock Nut, **(Figures 22 & 23)**. Do not tighten hardware.
14. Repeat **Steps 1—3** for the 2nd and 3rd passenger side Bracket installations. **NOTE:** Cradles on Brackets installed on passenger side will face forward.
  - a. **2017-on 2500/3500 DEF tank models:** Locate the 2nd tab bracket location along the bottom edge of the body, (pinch weld). Hold the DEF cover in place and mark the location onto the cover, **(Figures 24A & 24B)**. Use a sharp knife or hacksaw blade to carefully cut a slot in the plastic cover to clear the 2nd Bracket. Remove as little plastic as possible.
15. Repeat **Steps 7 & 8** to attach Passenger/Right Rear Brackets.
16. Repeat **Steps 9 & 10** to attach the Passenger/Right NB1 Running Board.
17. Once the Running Board has been installed and all hardware fully tightened, reinstall the DEF tank and cover, if equipped, as described in **Step 11**.
18. Do periodic inspections to the installation to make sure that all hardware is secure and tight.

**To protect your investment,** Do not use any type of polish or wax that may contain abrasives that could damage the finish. Mild soap may be used also to clean the Running Boards.

**NB1 WHEEL TO WHEEL RUNNING BOARDS**  
**07-18 1500 SILVERADO/SIERRA EXTENDED/DOUBLE CAB 6 1/2FT BED**  
**INCLUDES 19-21 SILVERADO 1500 LD & 19-21 SIERRA 1500 LIMITED**  
**07-19 25-3500 SILVERADO/SIERRA EXTENDED/DOUBLE CAB 6 1/2FT BED**  
**INCLUDES DIESEL W/DEF**

**Driver/Left Side Installation Pictured**

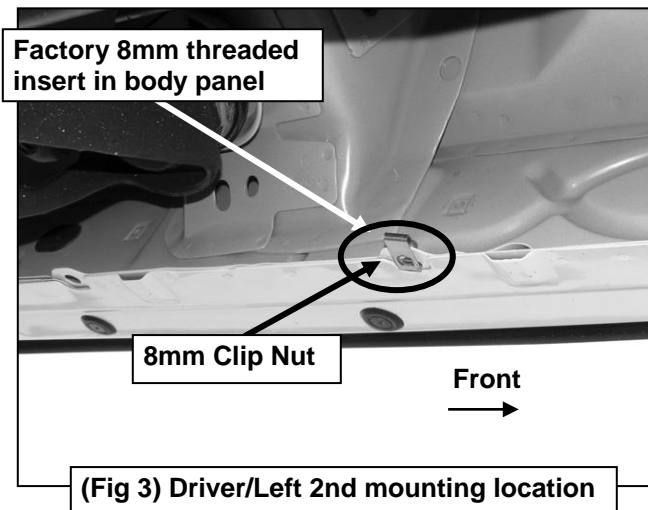
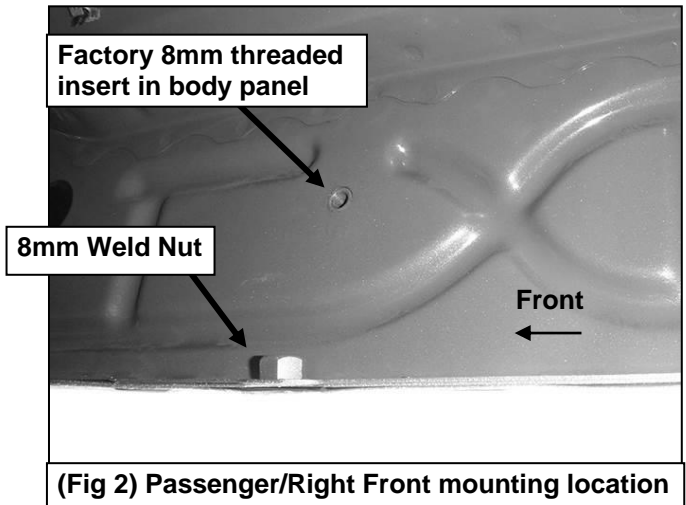
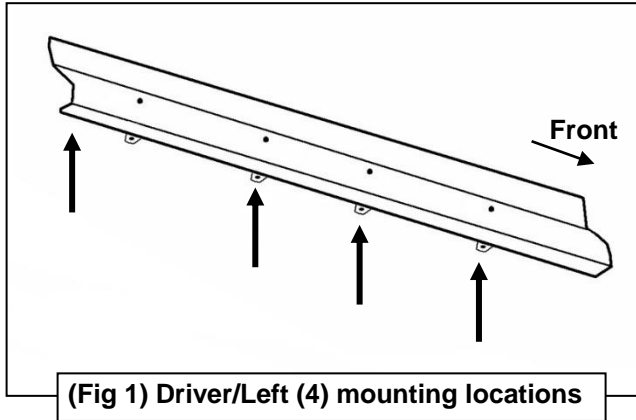

**NB1 WHEEL TO WHEEL RUNNING BOARDS**  
**07-18 1500 SILVERADO/SIERRA EXTENDED/DOUBLE CAB 6 1/2FT BED**  
**INCLUDES 19-21 SILVERADO 1500 LD & 19-21 SIERRA 1500 LIMITED**  
**07-19 25-3500 SILVERADO/SIERRA EXTENDED/DOUBLE CAB 6 1/2FT BED**  
**INCLUDES DIESEL W/DEF**

**Driver/Left Side Installation Pictured**

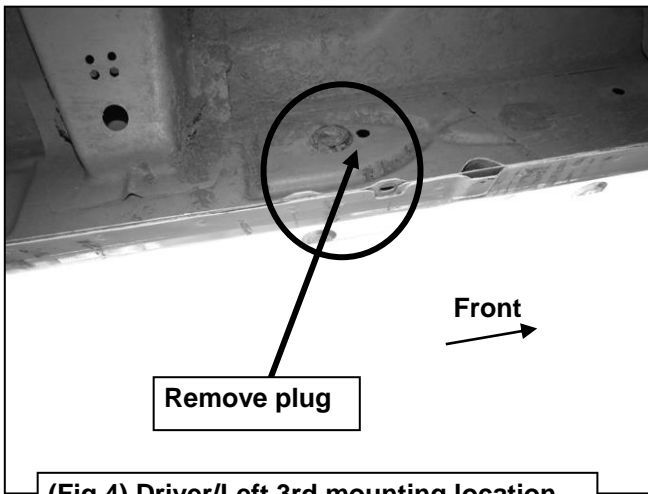

**(Fig 4) Driver/Left 3rd mounting location**

- (2) 8mm x 25mm Hex Bolts
- (2) 8mm Lock Washers
- (2) 8mm Flat Washers

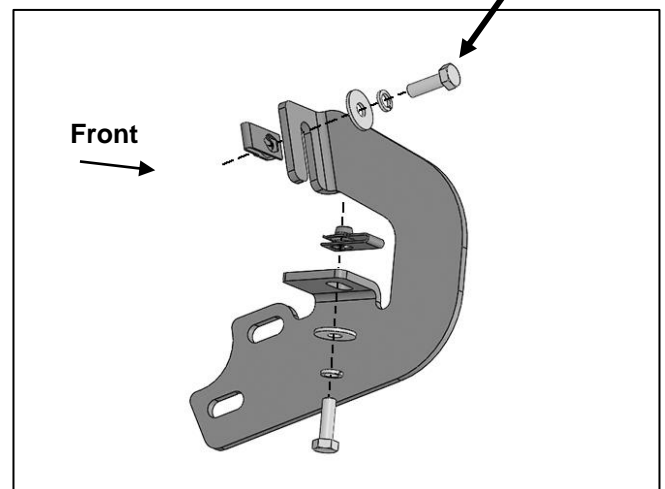

**(Fig 5) Driver/Left Front bracket installed**

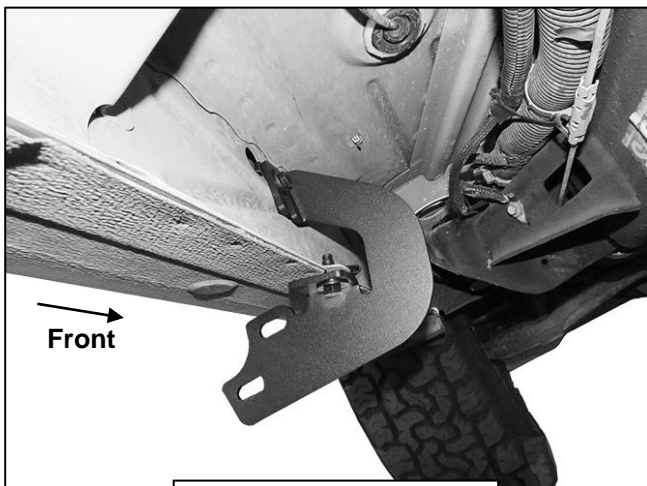

**(Fig 6) Driver/Left Front Bracket attached**

**NB1 WHEEL TO WHEEL RUNNING BOARDS**  
**07-18 1500 SILVERADO/SIERRA EXTENDED/DOUBLE CAB 6 1/2FT BED**  
**INCLUDES 19-21 SILVERADO 1500 LD & 19-21 SIERRA 1500 LIMITED**  
**07-19 25-3500 SILVERADO/SIERRA EXTENDED/DOUBLE CAB 6 1/2FT BED**  
**INCLUDES DIESEL W/DEF**

**Driver/Left Side Installation Pictured**

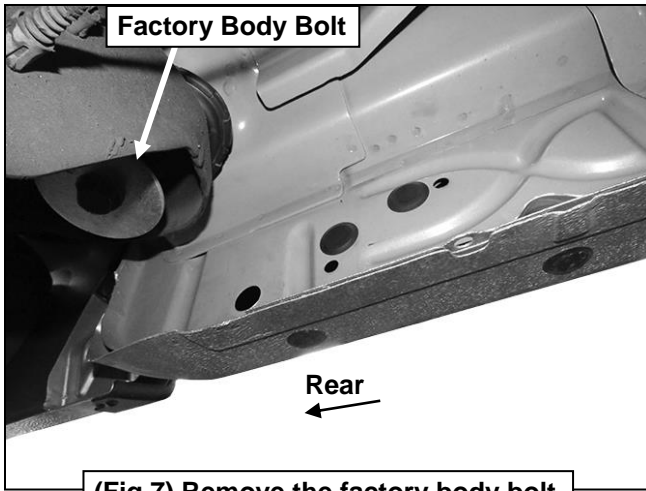

**(Fig 7) Remove the factory body bolt**

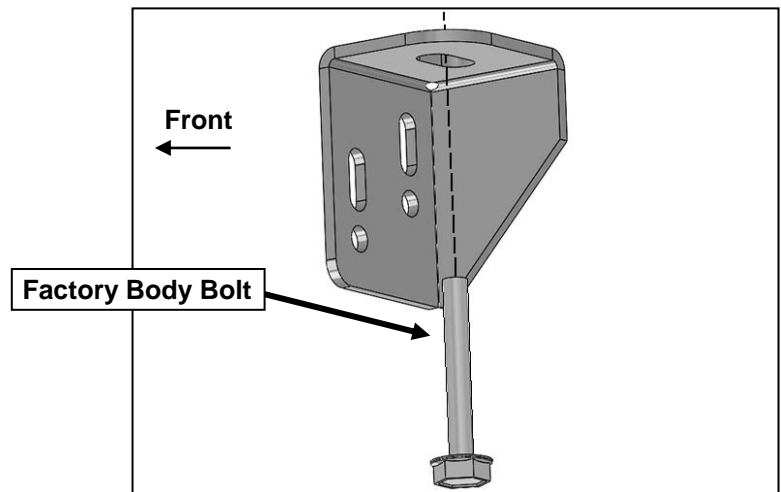

**(Fig 8) Factory Body Bolt installation**

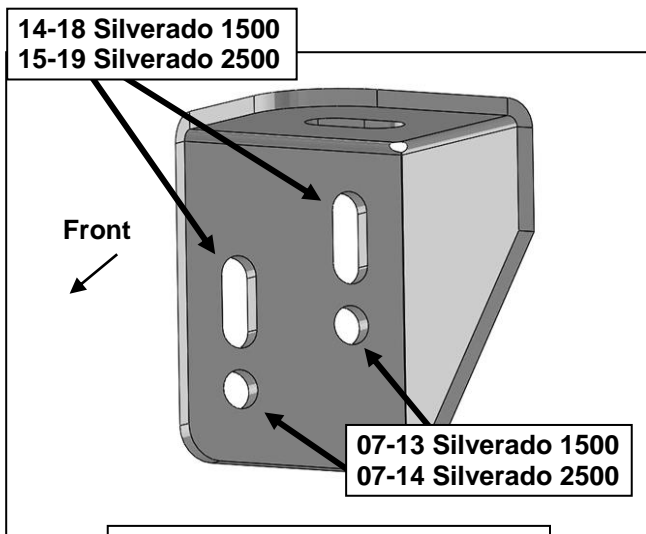

**(Fig 9) Driver/Left Body Bracket**

**NB1 WHEEL TO WHEEL RUNNING BOARDS**  
**07-18 1500 SILVERADO/SIERRA EXTENDED/DOUBLE CAB 6 1/2FT BED**  
**INCLUDES 19-21 SILVERADO 1500 LD & 19-21 SIERRA 1500 LIMITED**  
**07-19 25-3500 SILVERADO/SIERRA EXTENDED/DOUBLE CAB 6 1/2FT BED**  
**INCLUDES DIESEL W/DEF**

**Driver/Left Side Installation Pictured**

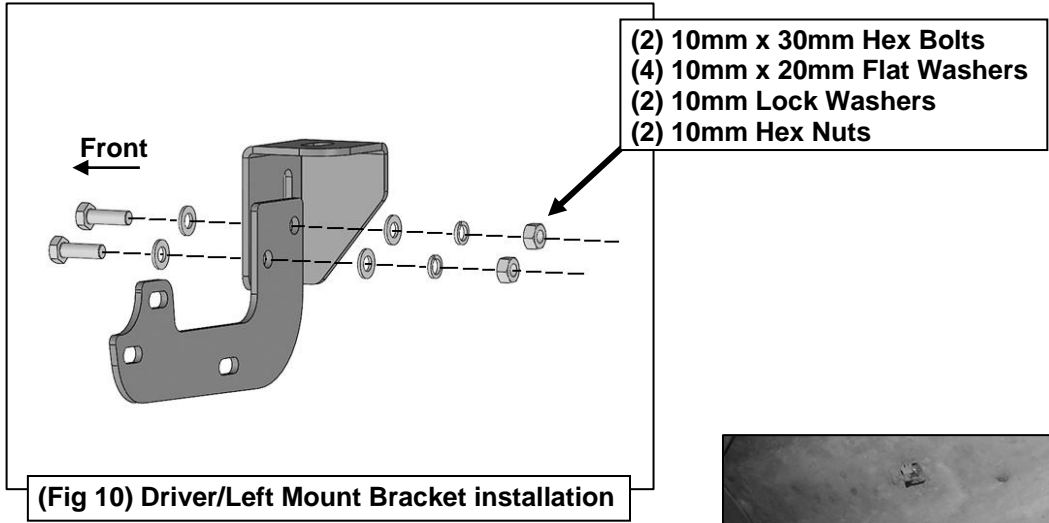

**(Fig 10) Driver/Left Mount Bracket installation**

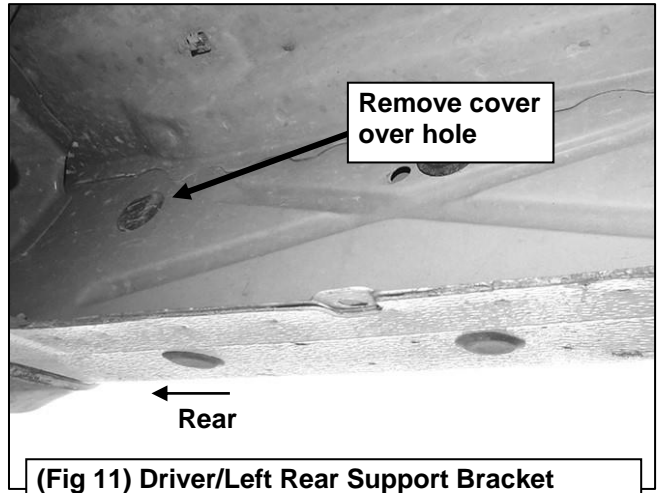

**(Fig 11) Driver/Left Rear Support Bracket mounting location. Remove the cover over the hole and insert (1) 10mm Bolt Plate into the hole with a Plastic Retainer to hold it in place**

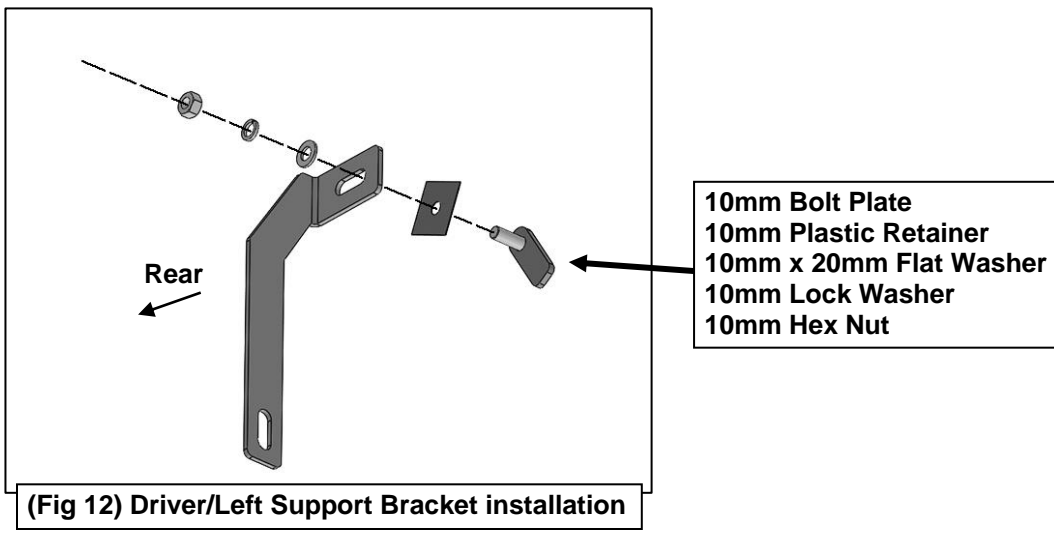

**(Fig 12) Driver/Left Support Bracket installation**

**NB1 WHEEL TO WHEEL RUNNING BOARDS**  
**07-18 1500 SILVERADO/SIERRA EXTENDED/DOUBLE CAB 6 1/2FT BED**  
**INCLUDES 19-21 SILVERADO 1500 LD & 19-21 SIERRA 1500 LIMITED**  
**07-19 25-3500 SILVERADO/SIERRA EXTENDED/DOUBLE CAB 6 1/2FT BED**  
**INCLUDES DIESEL W/DEF**

**Driver/Left Side Installation Pictured**

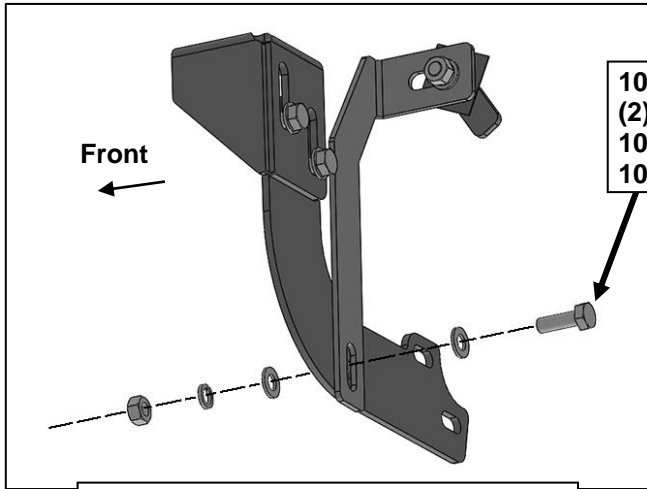

- 10mm x 30mm Hex Bolt
- (2) 10mm x 20mm Flat Washers
- 10mm Lock Washer
- 10mm Hex Nut

**(Fig 13) Driver/Left Support Bracket installation to Rear Mounting Bracket**

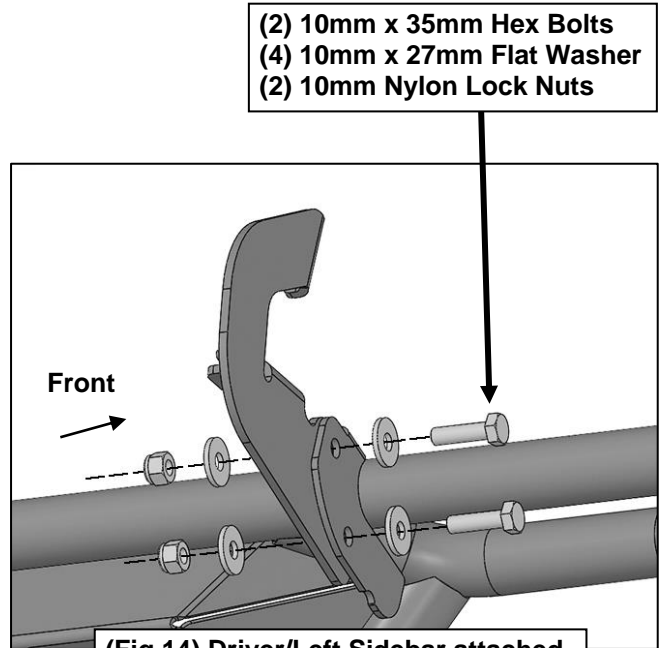

- (2) 10mm x 35mm Hex Bolts
- (4) 10mm x 27mm Flat Washer
- (2) 10mm Nylon Lock Nuts

**(Fig 14) Driver/Left Sidebar attached to Front Bracket illustrated**

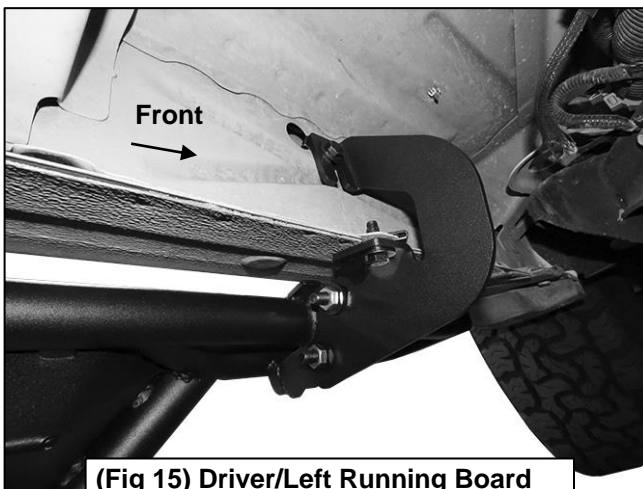

**(Fig 15) Driver/Left Running Board attached to Driver/Left Front Bracket**



**NB1 WHEEL TO WHEEL RUNNING BOARDS**  
**07-18 1500 SILVERADO/SIERRA EXTENDED/DOUBLE CAB 6 1/2FT BED**  
**INCLUDES 19-21 SILVERADO 1500 LD & 19-21 SIERRA 1500 LIMITED**  
**07-19 25-3500 SILVERADO/SIERRA EXTENDED/DOUBLE CAB 6 1/2FT BED**  
**INCLUDES DIESEL W/DEF**  
**Passenger/Right Side Installation Pictured**

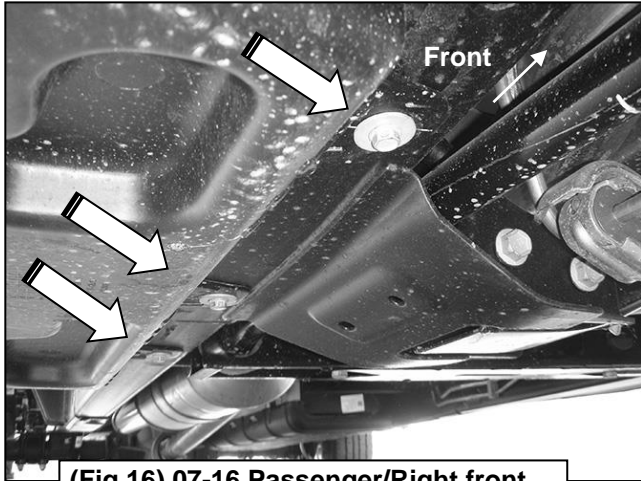

**(Fig 16) 07-16 Passenger/Right front**  
**pictured with DEF tank cover. Remove**  
**(3) hex bolts to remove cover**

**Remove (2) factory bolts**  
**to remove tank straps**

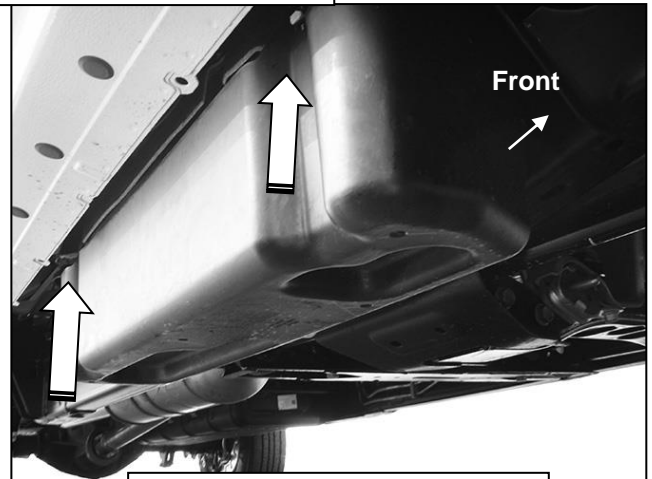

**(Fig 17) 07-16 Passenger/Right**  
**DEF tank and cover**

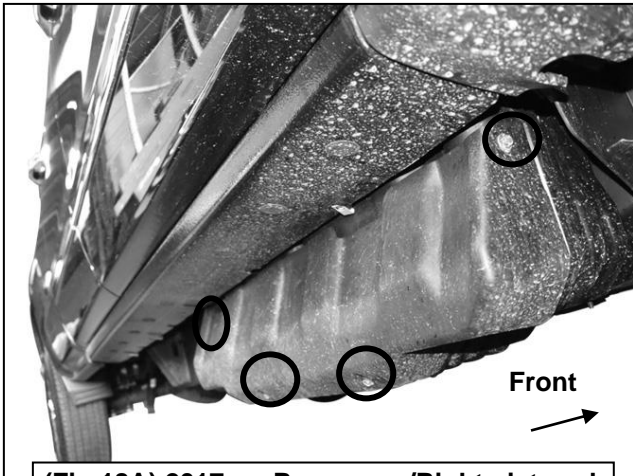

**(Fig 18A) 2017-on Passenger/Right**  
**pictured with DEF plastic tank cover. Remove**  
**(4) hex bolts to remove plastic cover**

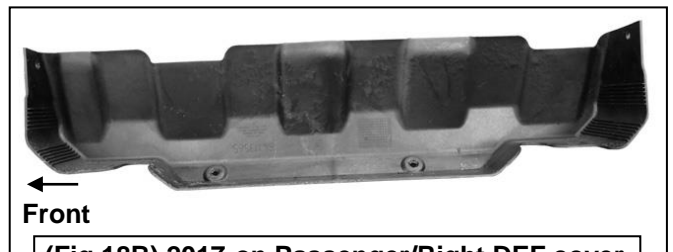

**(Fig 18B) 2017-on Passenger/Right DEF cover**

**NB1 WHEEL TO WHEEL RUNNING BOARDS**  
**07-18 1500 SILVERADO/SIERRA EXTENDED/DOUBLE CAB 6 1/2FT BED**  
**INCLUDES 19-21 SILVERADO 1500 LD & 19-21 SIERRA 1500 LIMITED**  
**07-19 25-3500 SILVERADO/SIERRA EXTENDED/DOUBLE CAB 6 1/2FT BED**  
**INCLUDES DIESEL W/DEF**  
**Passenger/Right side Installation Pictured**

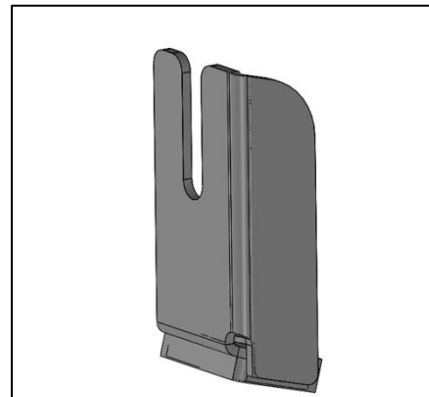

**(Fig 19) Passenger/Right Front Upper Bracket (all models)**

**8mm x 25mm Hex Bolt**  
**8mm Lock Washer**  
**8mm Flat Washer**

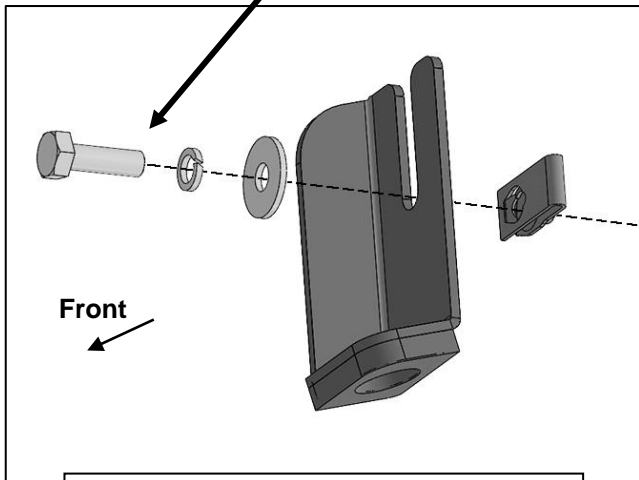

**(Fig 20) Slide Upper Bracket over weld nut if equipped-also see Figure 2**



**(Fig 21) 8mm x 35mm Bolt Plate**

**NB1 WHEEL TO WHEEL RUNNING BOARDS**  
**07-18 1500 SILVERADO/SIERRA EXTENDED/DOUBLE CAB 6 1/2FT BED**  
**INCLUDES 19-21 SILVERADO 1500 LD & 19-21 SIERRA 1500 LIMITED**  
**07-19 25-3500 SILVERADO/SIERRA EXTENDED/DOUBLE CAB 6 1/2FT BED**  
**INCLUDES DIESEL W/DEF**

**Passenger/Right side Installation Pictured**

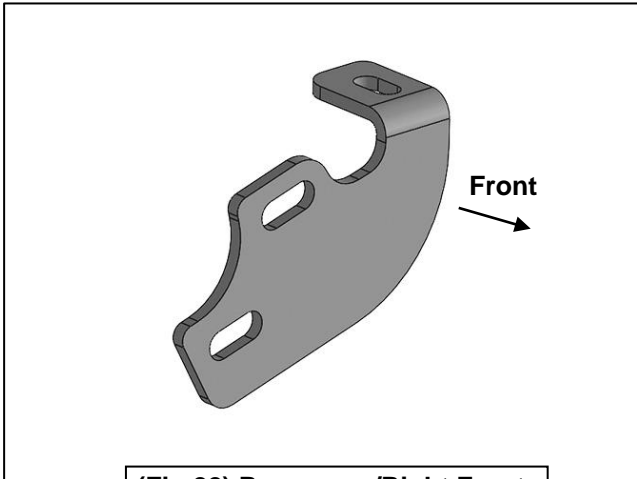

**(Fig 22) Passenger/Right Front Lower Bracket (all models)**

On models with flat tab and 8mm Bolt Plate (see Fig. 21) use:  
 8mm Flat Washer  
 8mm Nylon Lock Nut  
 to attach Lower Bracket to Bolt Plate

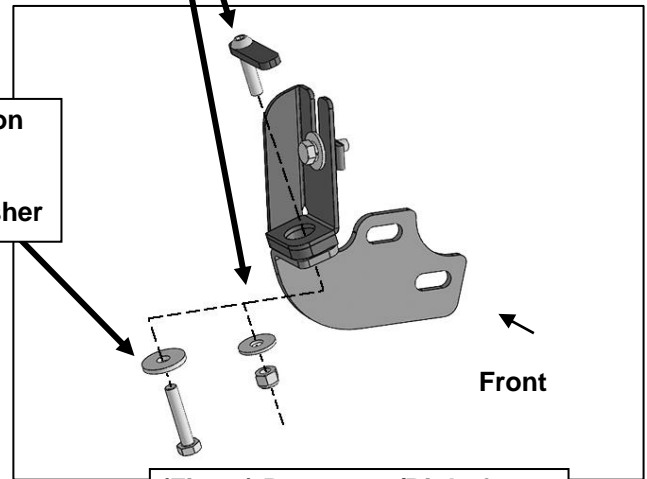

**(Fig 23) Passenger/Right front Bracket installation**

Models with weld nut on tab (see Fig. 2) use:  
 8mm x 40mm Hex Bolt  
 8mm x 28mm Flat Washer



**(Fig 24A) 2017-on DEF tank Mark for cut is approximately 70mm x 10mm**



**(Fig 24B) 2017-on Passenger DEF cut for example only**