

INSTALLATION INSTRUCTIONS

Mechanical PARTS LIST:

Qty	Item Description	Qty	Item Description
2	Running Boards	4	8-1.25mm x 30mm Hex Bolts
1	Driver/Left Front Bracket Assembly	4	8mm Lock Washers
1	Passenger/Right Front Bracket Assembly	8	6-1.0mm x 25mm Hex Bolts
1	Driver/Left Rear Bracket Assembly	16	6mm x 22mm OD x2mm Flat Washers
1	Passenger/Right Rear Bracket Assembly	8	6mm Nylon Lock Nuts
1	Electronic Materials Package	8	6mm Flange Nuts
4	9mm ID x 33mm x 4mm Square Washer Plates	8	6-1.0mm x 20mm Carriage Bolts
15	Zip Ties		

Electronic Materials Package PARTS LIST:

Qty	Item Description	Qty	Item Description
1	Main Harness	1	ECU
2	Wire Taps	4	LED lights
1	LED Y-Harness (280mm)	1	LED Y-Harness (1200mm)

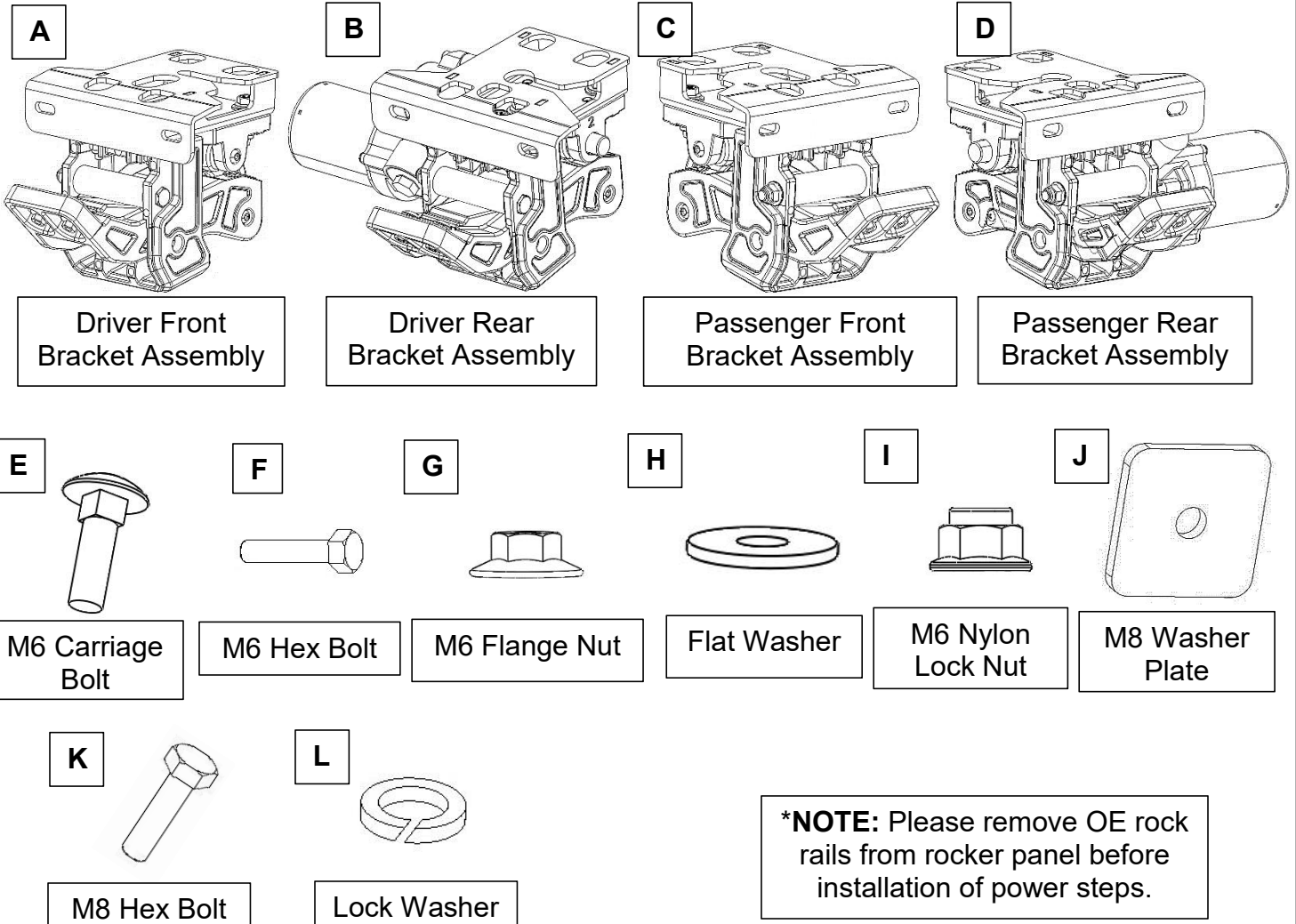

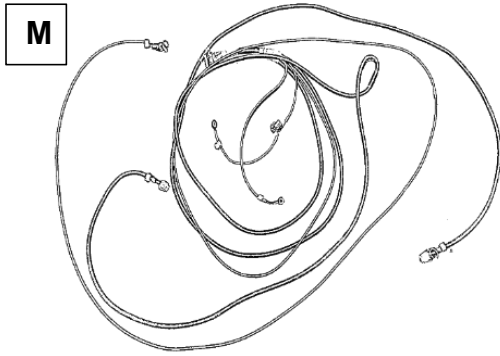

Main Harness

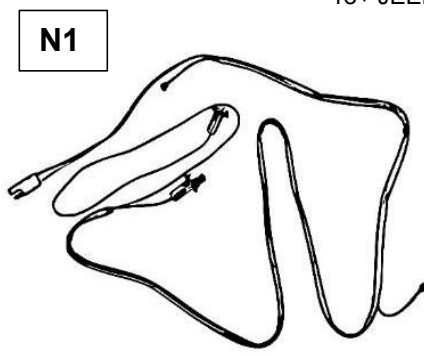

LED Y-Harness (Long)

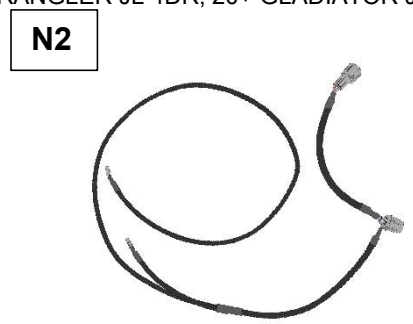

LED Y-Harness (Short)

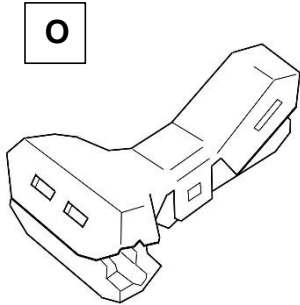

Wire Taps

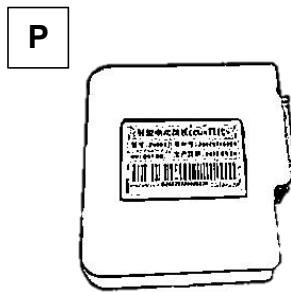

ECU

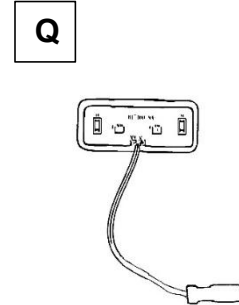

LED Lights

TOOLS REQUIRED

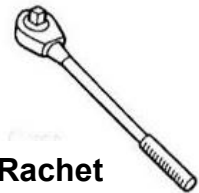

Ratchet



8mm
10mm
13mm

Socket



Extensions



Wrenches

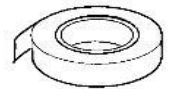

Electrical Tape

1

Locate the Driver Side center mounting points on the rocker panel under the B-Pillar (between front door and rear door). Loosely screw in the M8 Hex Bolt (K), M8 Lock Washer, and Washer Plate (J) into the upper threaded insert. Do **not** screw in all the way yet. The bracket will slide into the space between the bolt and rocker panel and will be tightened later.

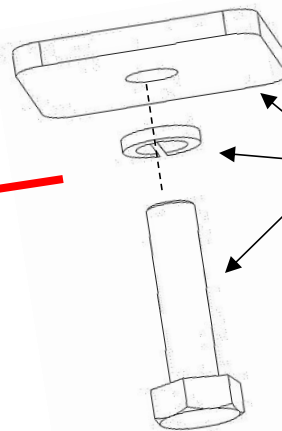

M8 Washer Plate
+
M8 Lock Washer
+
M8 Hex Bolt

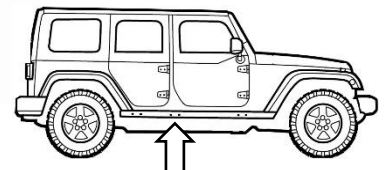

2

Next, line up front mounting bracket slots to the holes on the pinch weld and the M8 Hex Bolt (K), and then place Driver Side/Left Front Bracket Assembly (A) onto rocker panel. Then fasten the M6 Bolts (F), Nylon Lock Nuts (I), washers (H), and the M8 Bolt (K). Do not tighten all the way yet.

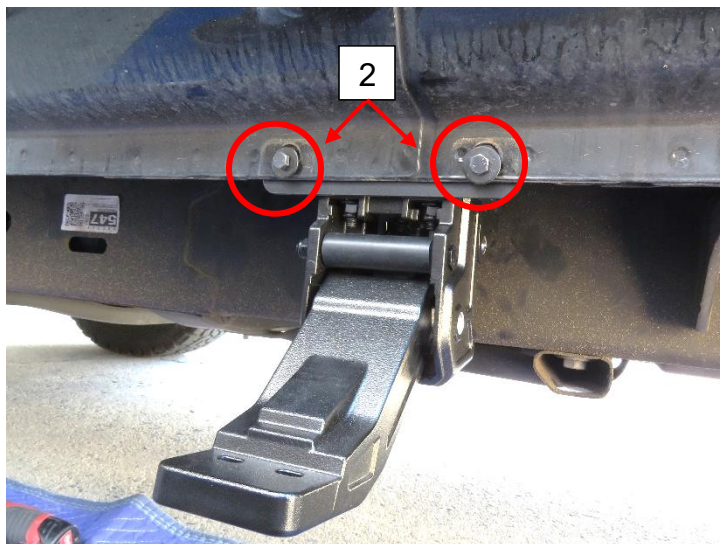
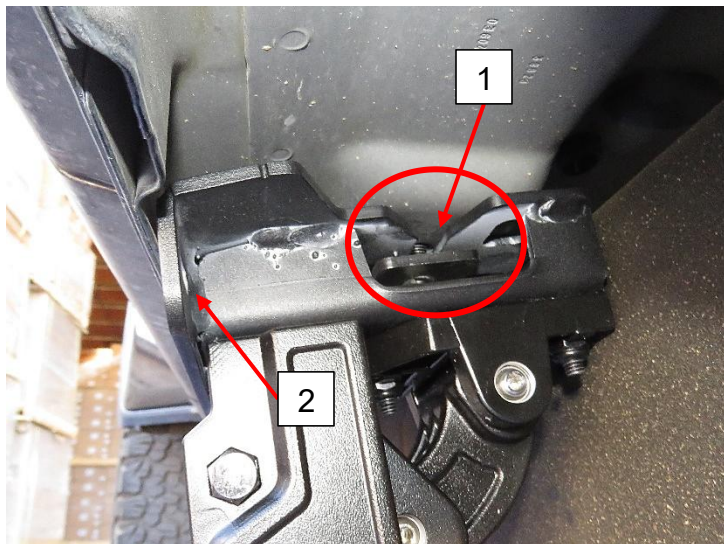

3

Locate rear mounting points. Repeat step 1 for the rear mounting point. Next, line up rear mounting bracket slots to the holes and M8 Hex Bolt (K), and then slide the Driver Side/Left Rear Bracket Assembly (B) into place. Position the bracket so that the holes on the pinch trim and the bracket line up. Then fasten the M6 Bolts (F), Nylon Lock Nuts (I), washers (H), and the M8 Bolt (K). Tighten the M8 bolt first, then the M6 bolts.

First insert bolt + plate

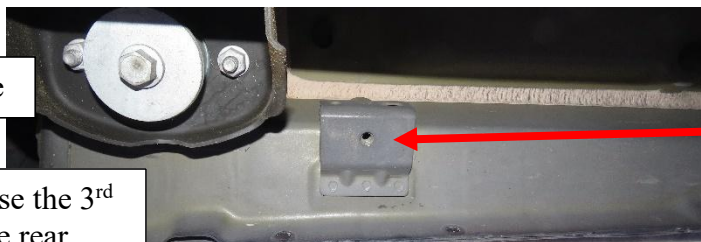

*Note: For Gladiator JT, use the 3rd mounting point towards the rear.

Then slide bracket into place

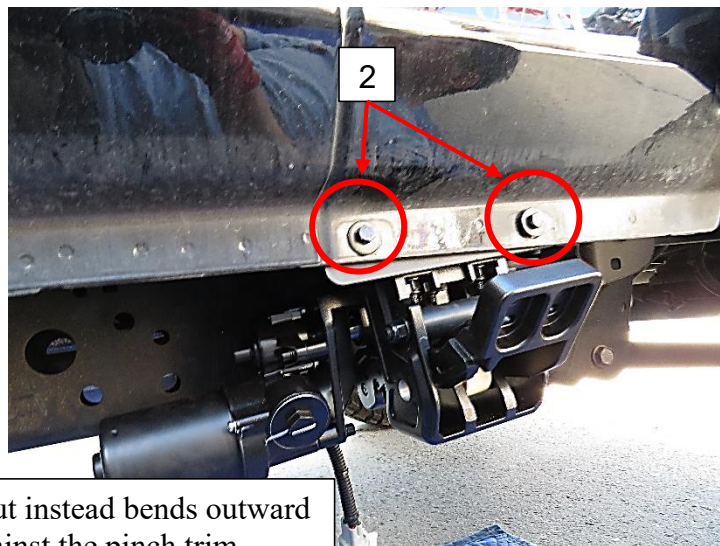
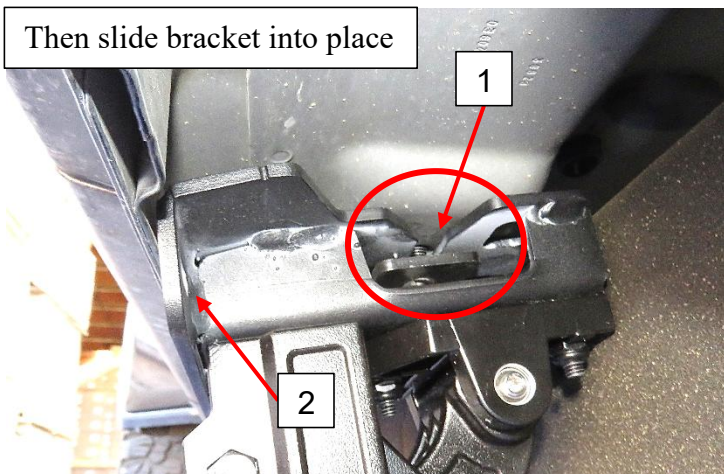

*Note: The body of the vehicle is not totally straight but instead bends outward slightly. Be sure to push the bracket assembly fully against the pinch trim.

4

Repeat steps 1 – 3 for the Passenger Side.

5

Start from the engine compartment by opening the front hood of the vehicle. Locate the Battery and its terminals (positive/negative). Remove the 25A fuse from the fuse box that comes with the main harness (M).

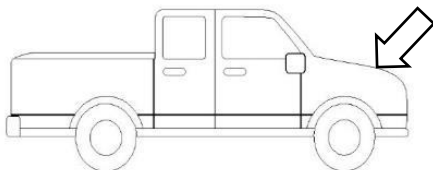

***WARNING:** Keeping the fuse connected to the fuse box may result in electrical sparks and risk of shorting when working with the battery.

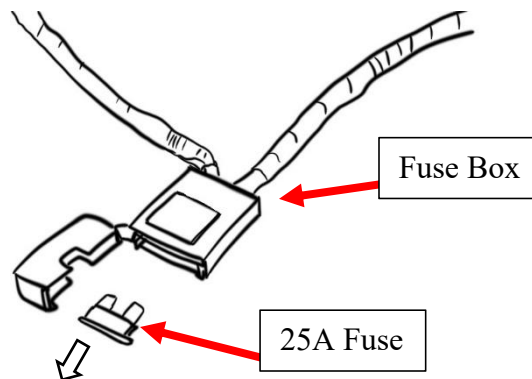

6

Connect the positive power lead on the main harness (M) to the positive battery terminal. Connect the negative lead to the negative battery terminal.

Make sure both power leads are fully secured. Then Connect the ECU (P) to the main harness and locate a space to place and secure to ECU.

Connect the Long LED Y-Harness (N1) to the Driver-side branch of the main harness. Connect the Short LED Y-Harness (N2) to the Passenger-side branch of the main harness.

***NOTE:** Battery is on the Passenger Side of the engine compartment.

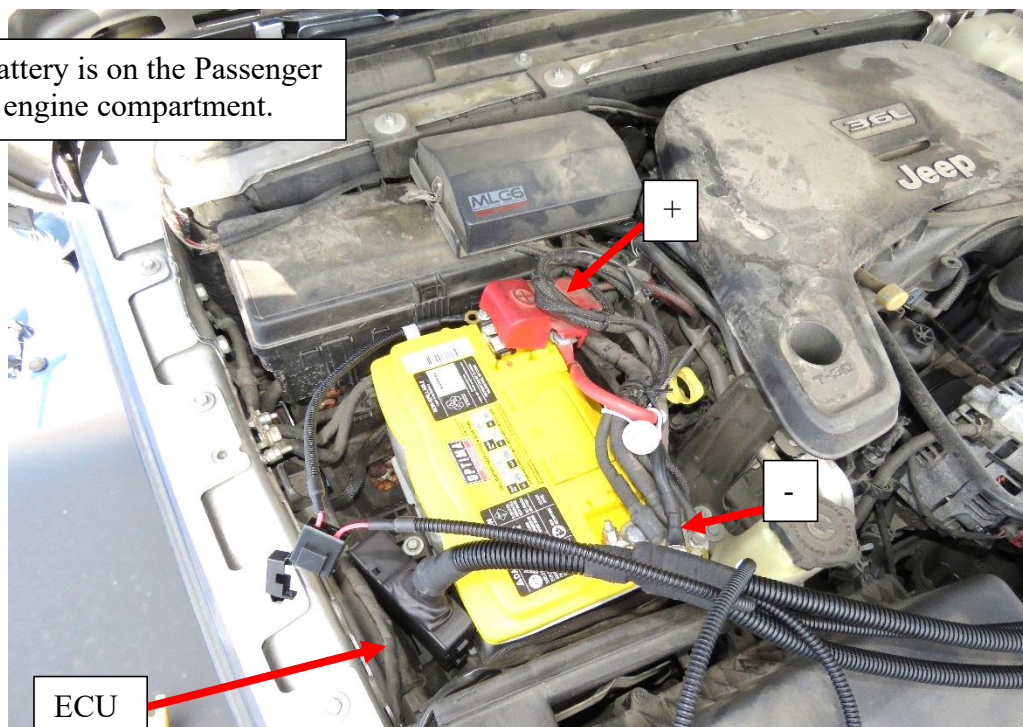

7

Route the main harness (M) around the battery, up along the rear of the engine compartment, and the Driver Side leg down the Driver-side frame. Route the Passenger Side leg of the harness down the Passenger-side wheel well. **Be sure to avoid contact with any moving or hot engine components.** Attach and secure the main harness (M) with supplied cable ties.

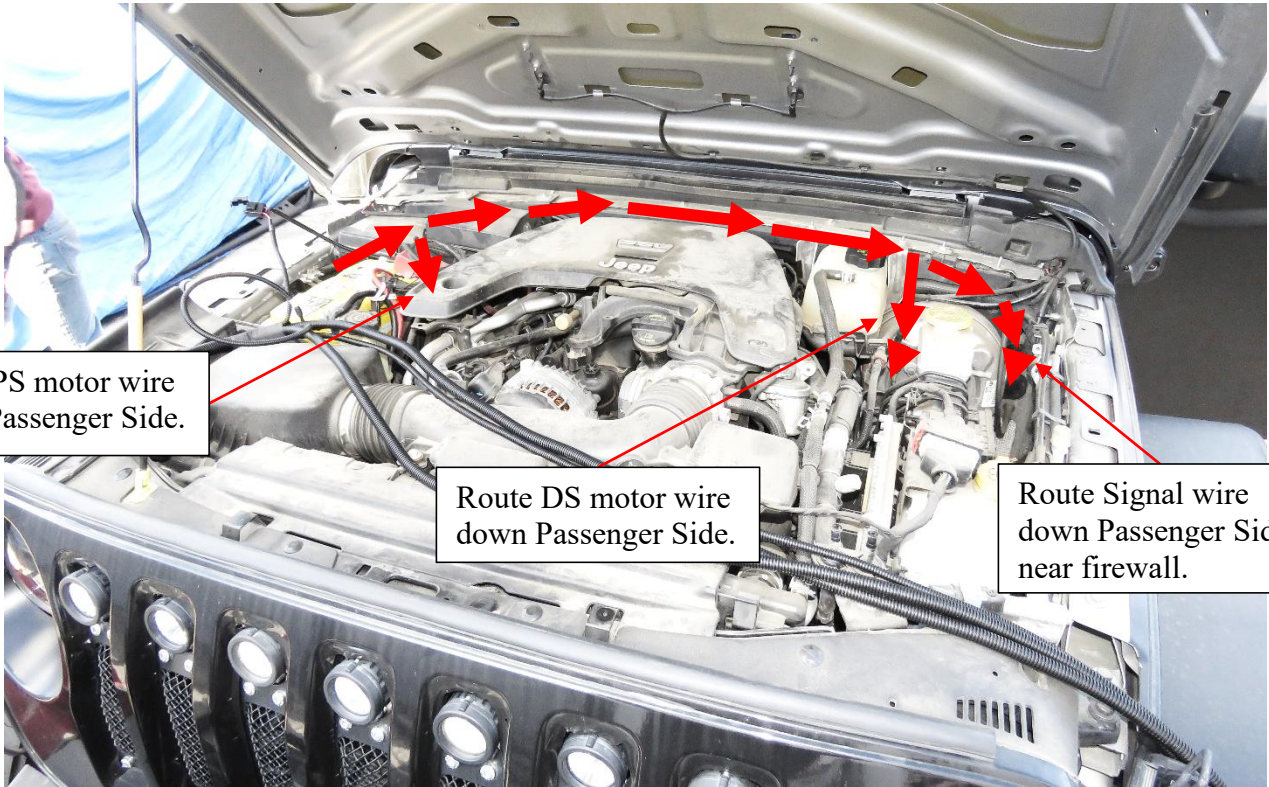

Route PS motor wire
down Passenger Side.

Route DS motor wire
down Passenger Side.

Route Signal wire
down Passenger Side,
near firewall.

8

Inside the vehicle cabin, locate the rubber grommet connecting to the firewall. The grommet is found under the dash panels, behind the OBD port, and up into the cabin-side firewall. Poke a hole through the grommet and feed the signal wires through.

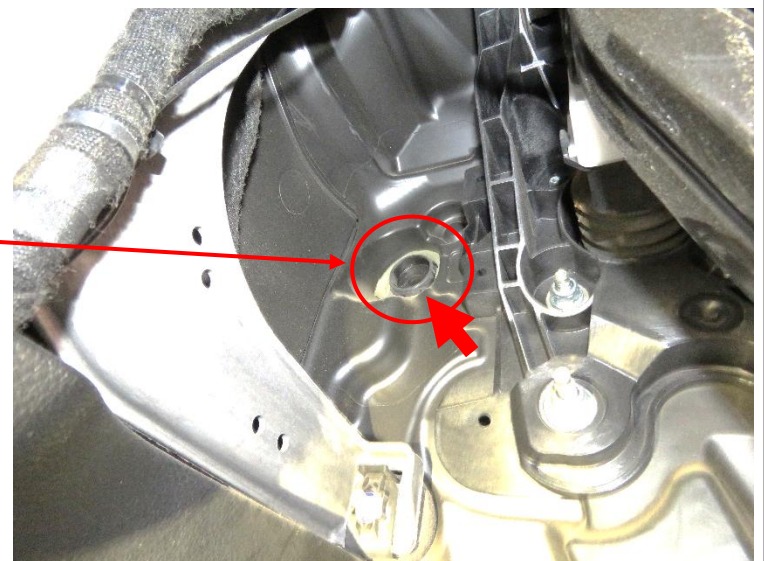

Once the signal leg of the main harness is fed through the grommet, route the wiring under the carpet and through the side of the bottom of the center console area. It is recommended to use the vacant space between the center console bracketry.

Route signal wire under carpet and up to center console

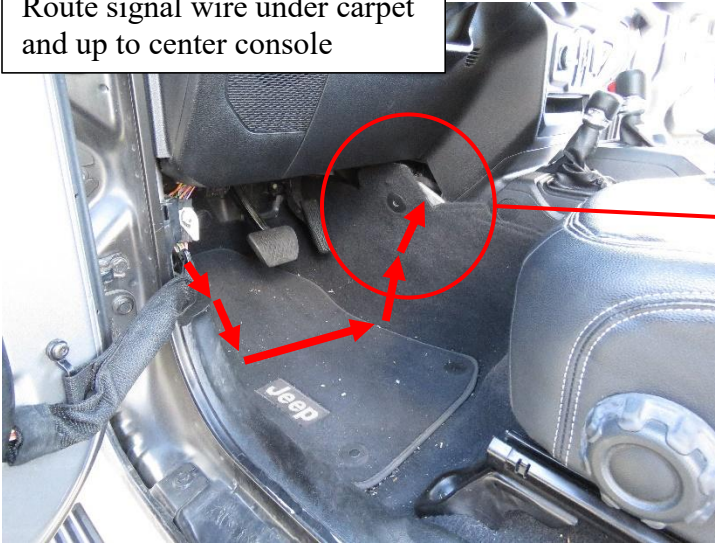

Route through the empty space under the console.

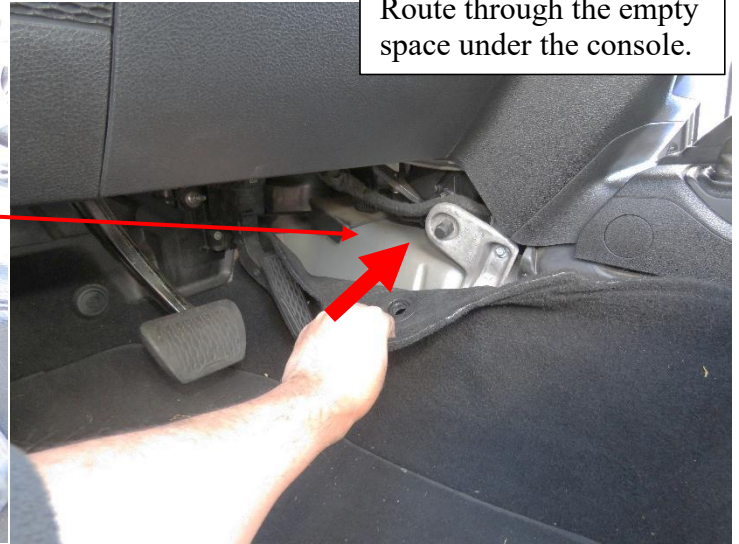

Route through the gap out to the other side.

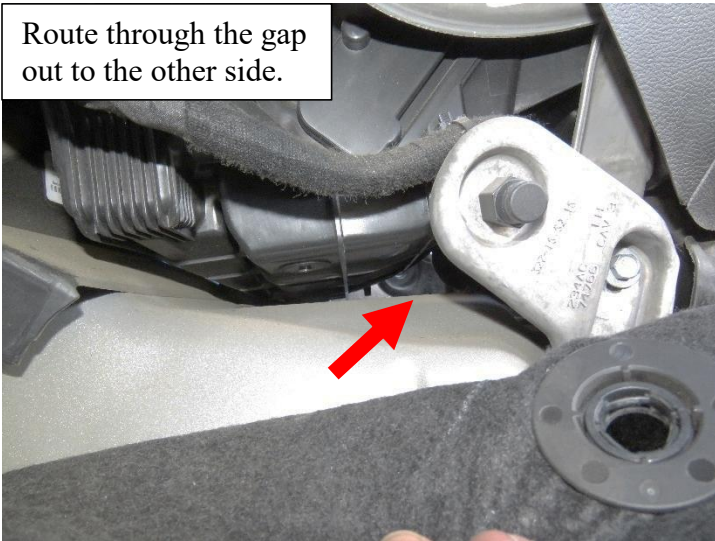

Remove carpet if needed, and route under and up to glove box.



9

Attach the main harness (M) to one LED Y-Harness (N). Then attach the LED Y-Harness (N) to the motor on the Driver Side. Repeat for Passenger Side.

Driver side

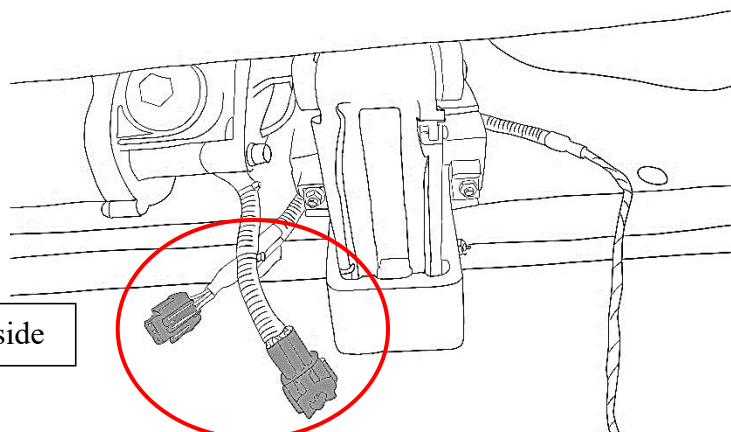

Open the glove box and locate the safety tab at the back of the box. Press and release the glove box safety tab and remove the glove box.



Unhook strut by pushing up.

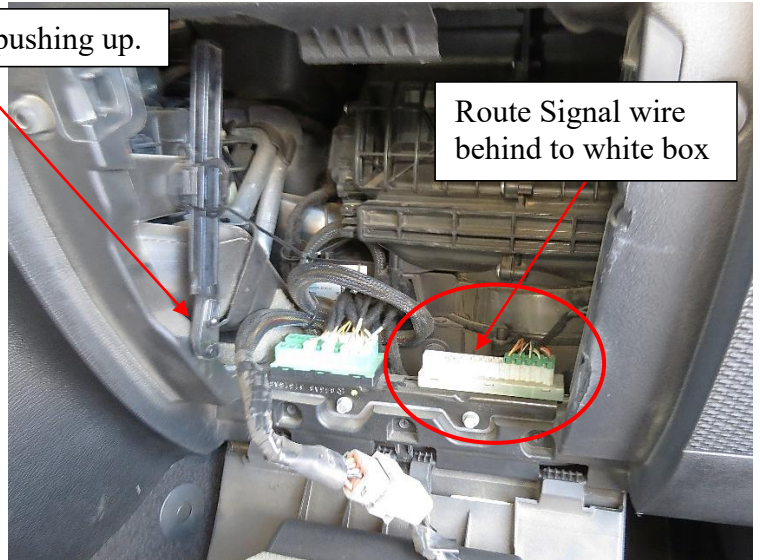

Route Signal wire behind to white box

Identify the configuration of the plugs on the CAN Bus hub. Locate the white hub on the right side. Select the any of the plugs with two wires extending from it. The wire closer to the plug's retaining tab is the CAN High wire. Confirm the vehicle is powered off. Then connect the High and Low wires from the main harness (M) using the supplied wire taps (O). Be sure the signal wire routing allows the glove box to close.

NOTE: Wire taps supplied with kit. Please see next page for guide.

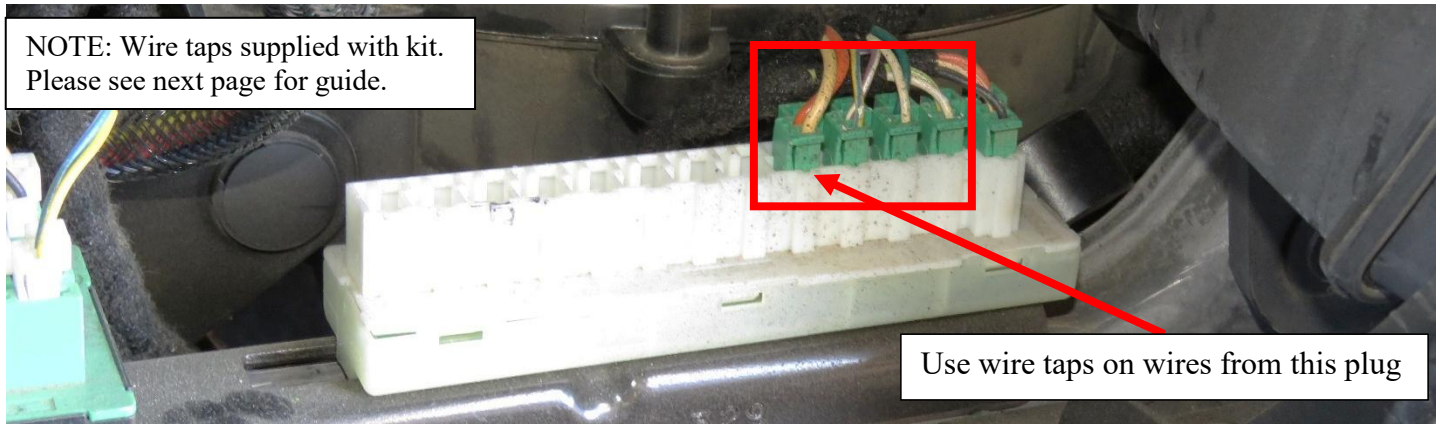

Use wire taps on wires from this plug

Factory CAN Wire	Main Harness wire color
Yellow (CAN-L)	Yellow (Low)
Orange (CAN-H)	White (High)

*NOTE: Some colors may differ from vehicle to vehicle. It is recommended to use the OE plug as a reference point when identifying the CAN High and CAN Low wires. (High is next to plug tab, inner side)

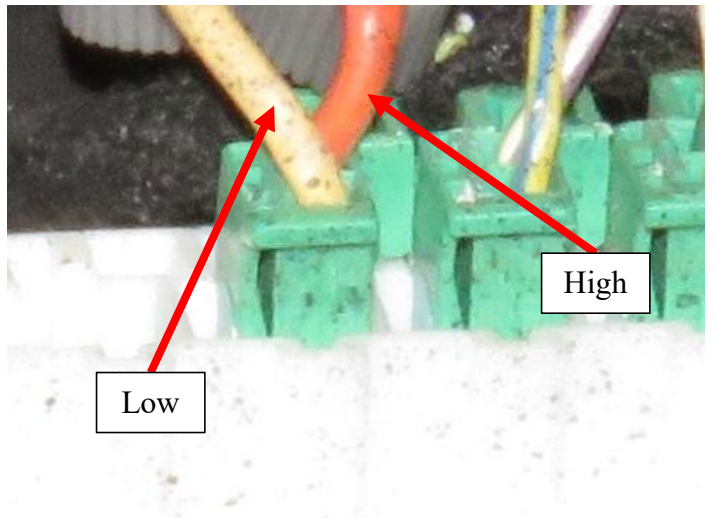

Low

High

The kit comes supplied with wire taps called "shark taps". Follow the guide below to tap the wire using the "shark tap":

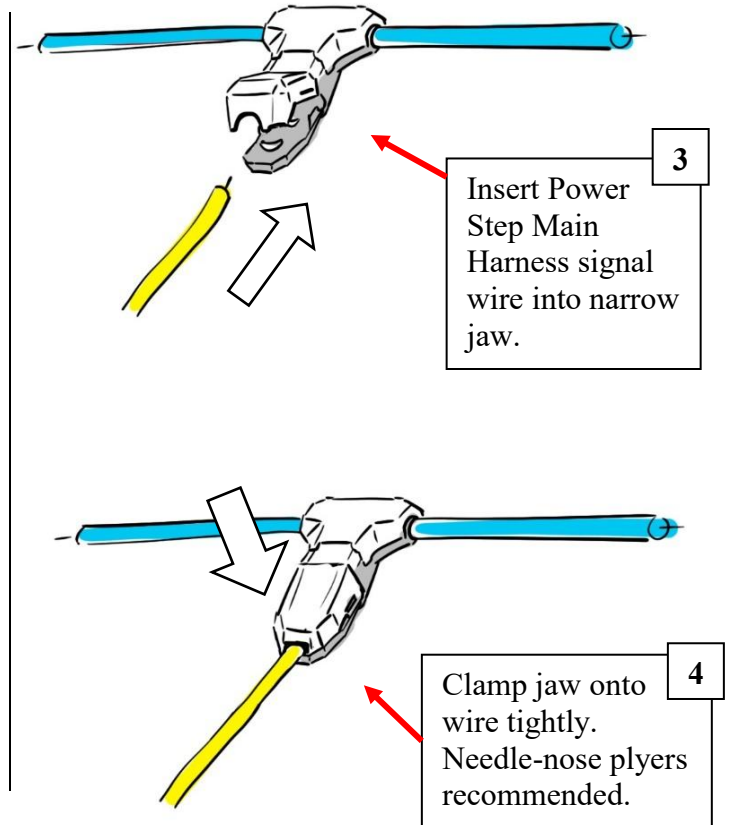
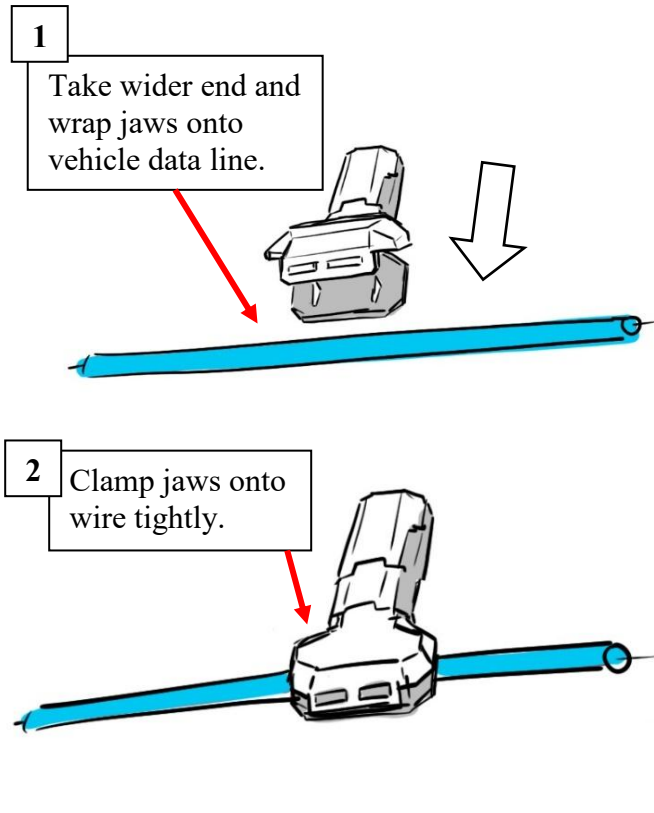

NOTE: Make sure wire is seated properly in the jaws before clamping. The wire being tapped must be centered on the "teeth" to make a proper tap.

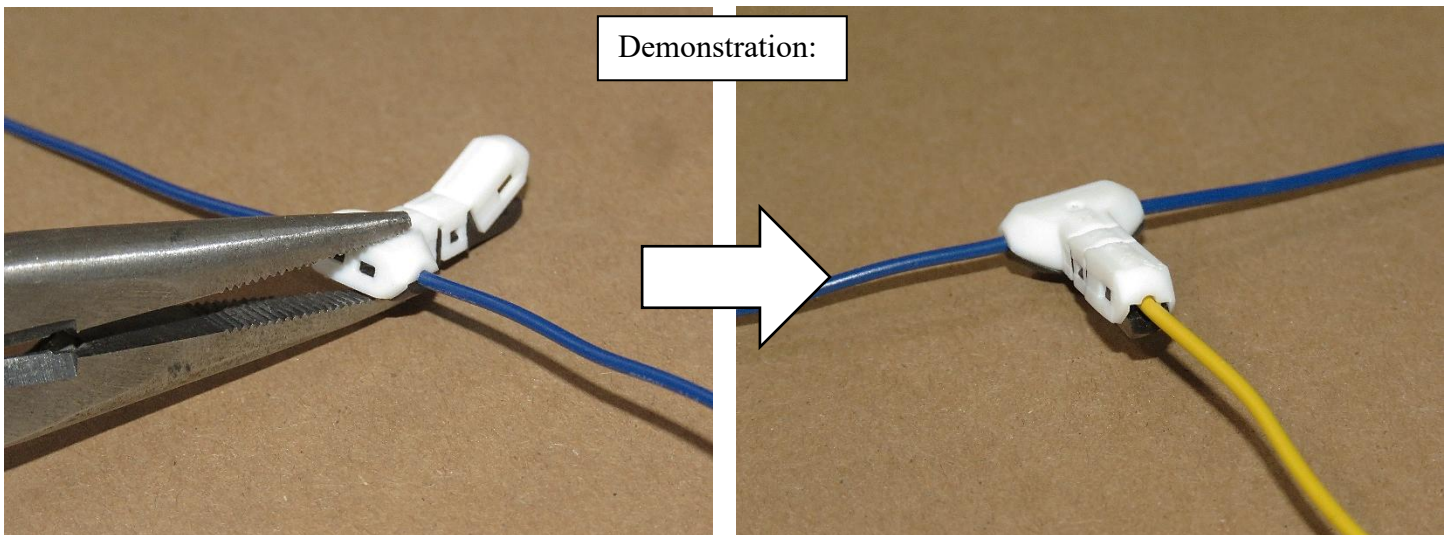

11

Plug in LED lights (Q) into LED Y-Harness (N) and attach them to the bottom of the rocker panel. Use provided 3M double sided adhesive tape on back of LED light (Q). Replace Fuse into Fuse Box.

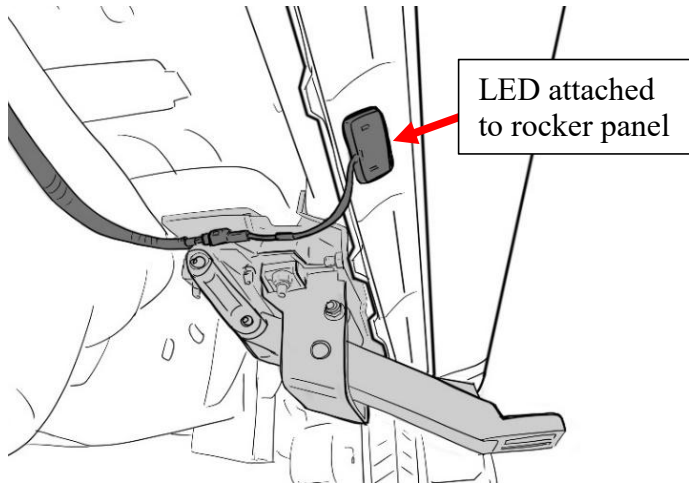

Close lid after replacing Fuse

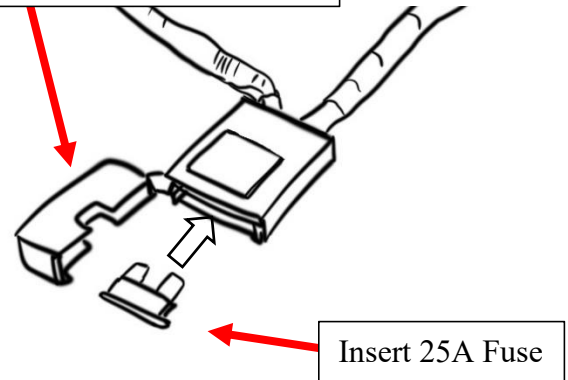

12

Check to make sure the harnesses on the Driver Side/Left Front Bracket Assembly (A) and Passenger Side Front Bracket Assembly (C) are connected to the main harness (M) via the LED-Y harnesses (N).

*NOTE: The linkage arms on the front bracket assemblies will not move unless both motors are connected.

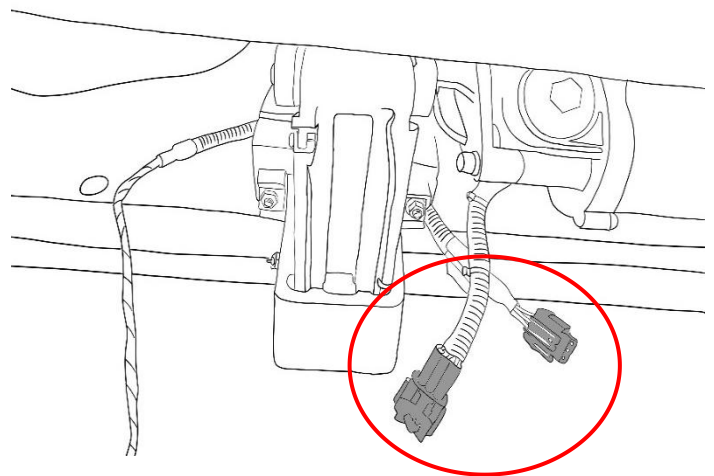

13

Seal the grommet in the firewall with RTV Silicone Sealant.

Hide wires and reattach any panels and carpet that was removed. Reattach the **glove box** and check to make sure there are no obstructions or potential snag points around the brake pedal area.

Be sure that the glove box can open And close without snagging on any wires.

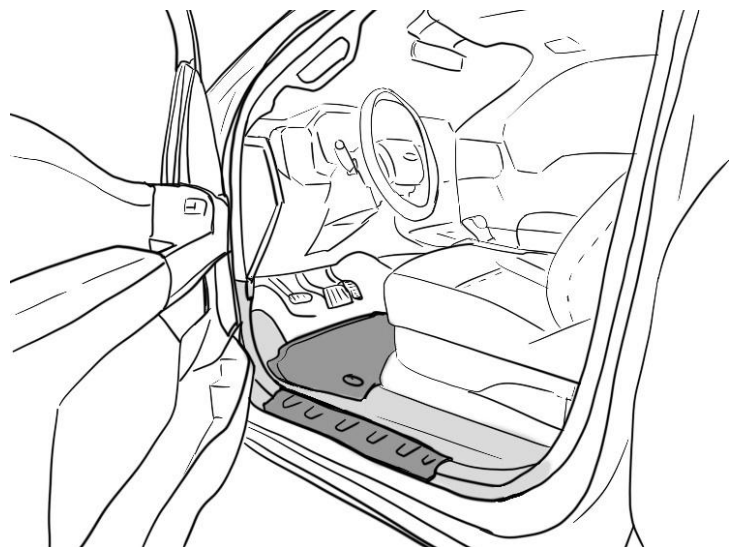

Prepare the power step boards. Locate the end of the boards and slide the M6 Carriage Bolts (E) into the channel on the underside of the board. Insert a total of 4 carriage bolts (E).

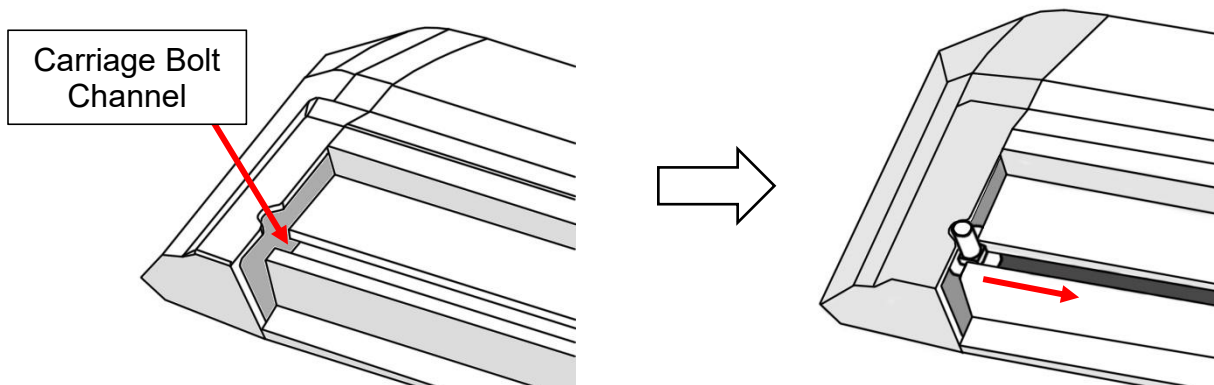

Use the notch in the board's end caps to feed the bolts into the channel.

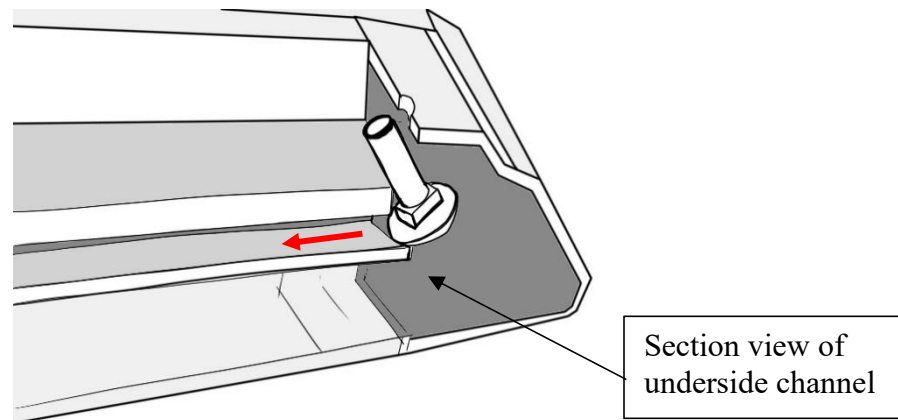

15 Perform a function check by closing the driver side front door and opening it again. The front bracket assembly (A) motor should activate the linkage arm and move it into the down or "deployed" position.

After deploying linkage arms, unplug main harness connector, while front door is open, to hold deployed position for running board installation.

Line up the carriage bolts (E), under the power step boards, with the slots on the linkage arms (A & B). Insert the 4 carriage bolts (E) into the slots on front and rear linkage arms. Adjust board to desired position. Moderately hand tighten the flange nuts (G) onto the carriage bolts.

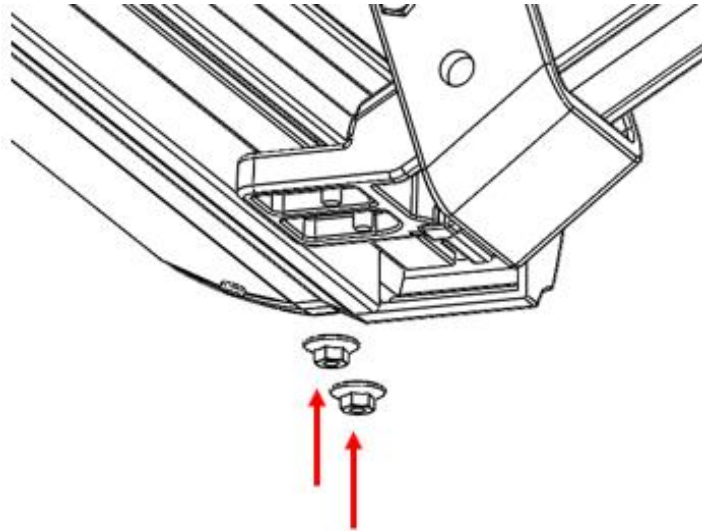

Once the board is adjusted, plug in main harness (M) connector to return power to the linkage arms. Open and close doors several times to deploy and retract the steps to settle the steps into their natural alignment. After cycling the step, tighten all hardware on the board and brackets.

Some further adjustment may be required for desired step position. Repeat for passenger side.

16 Perform system check and troubleshooting. If board is making irregular movements or noise, readjust the boards as follows:

- a) With board deployed loosen 6mm flange nuts under board.
- b) Leave the flange nuts slightly less than snug.
- c) Open and close door several times for board to settle into position.
- d) With the step in the deployed position, gradually tighten flange nuts while alternating between each. Do not over tighten.

If board is making abnormal noise or the motion is binding, repeat steps “a” through “d”.

Note: If the above method does not resolve the issue, the brackets mounting to the vehicle may not be aligned properly with the vehicle. In this case, remove the board and realign brackets before attempting steps “a” to “d” once again.

Reinstall any remaining trim panels if necessary. Check and make sure all hardware is fully tightened. Perform a final system check. Finish.

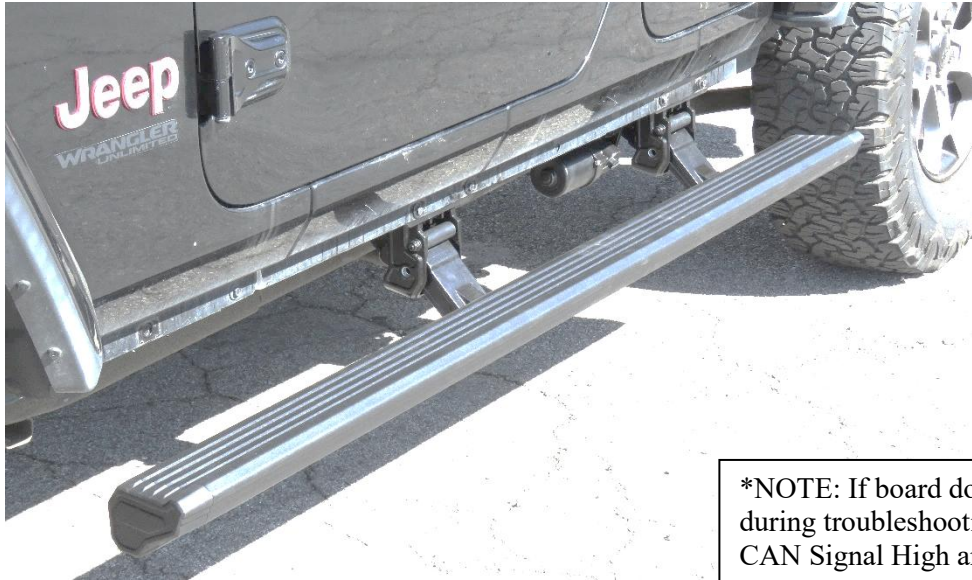

***NOTE:** If board does not move during troubleshooting, check the CAN Signal High and Low wires.