

## INSTALLATION INSTRUCTIONS

### Mechanical PARTS LIST:

Qty	Item Description	Qty	Item Description
2	Running Boards	16	8mm Lock Washers
1	Driver/Left Front Bracket Assembly	8	8-1.25mm x 25mm Hex Bolts
1	Passenger/Right Front Bracket Assembly	8	8mm x 24mm x 2mm Large Flat Washers
1	Driver/Left Rear Bracket Assembly	4	8mm Flange Nylon Lock Nuts
1	Passenger/Right Rear Bracket Assembly	8	8-1.25mm x 30mm Hex Bolt s
1	Electronic Materials Package	4	6mm Double Nut Plates
2	Support Bracket 1 (A)	8	6mm Flange Nuts
2	Support Bracket 2 (B)	8	6-1.0mm x 20mm Carriage Bolts
4	8mm Plastic Insulators	8	6mm x18mm x 1.6mm Flat Washers
4	8mm Bolt-Nut Plates	8	6mm Lock Washers
8	8mm x 16mm x 1.6mm Flat Washers	8	6-1.0mm x 25mm Hex Bolts
1	Rubber Sleeve	15	Zip Ties

### Electronic Materials Package PARTS LIST:

Qty	Item Description	Qty	Item Description
1	Main Harness	1	ECU
2	Wire Taps	4	LED lights
1	LED Y-Harness (280mm)	1	LED Y-Harness (1200mm)

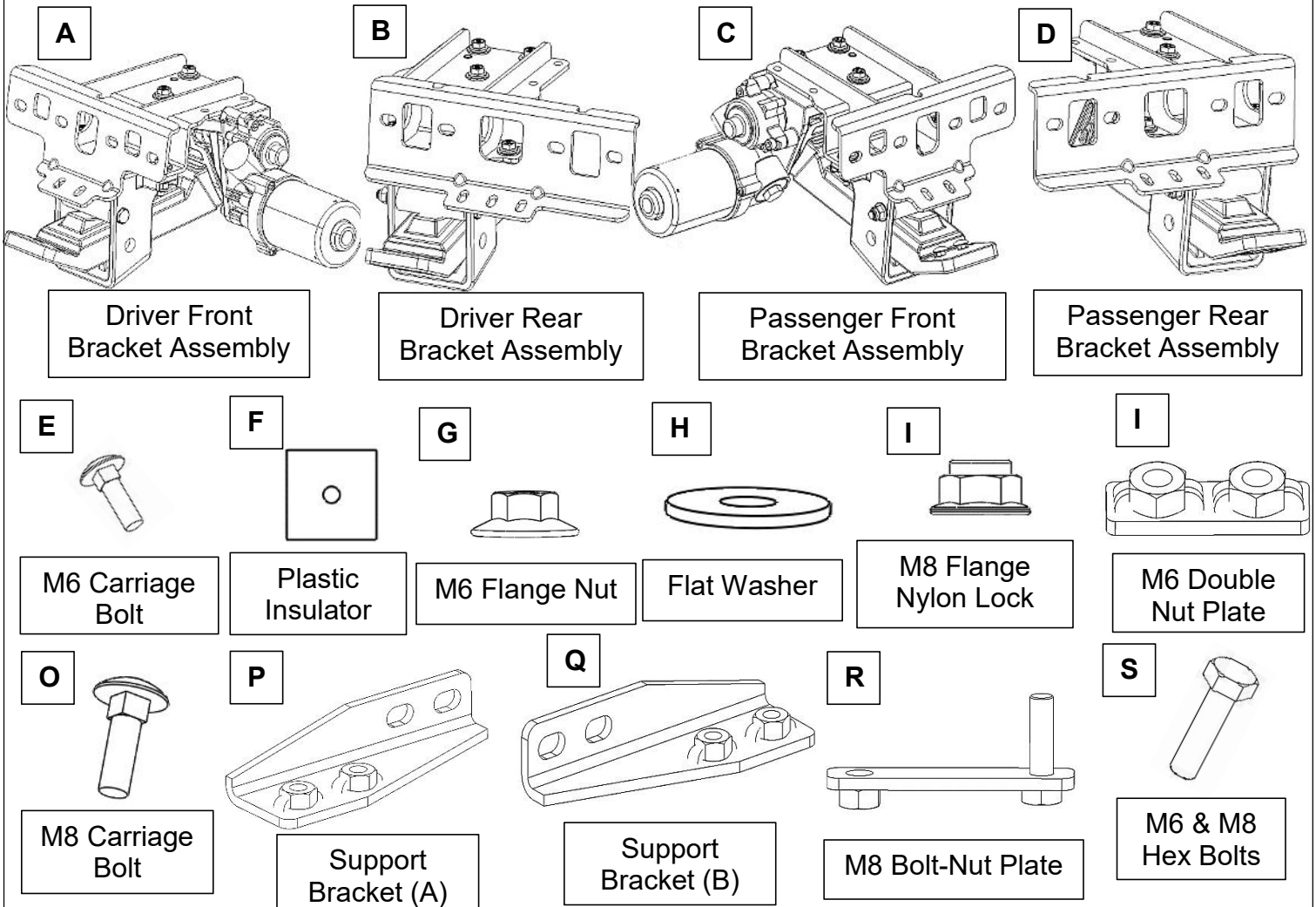

13-18 DODGE RAM 1500 (Incl. 2019 Ram 1500 Classic) & 13-24 DODGE RAM 2500/3500 QUAD CAB/CREW CAB/MEGA CAB  
 (Excl. Diesel Chassis Cab Models and models with Air Ride Suspension tanks)

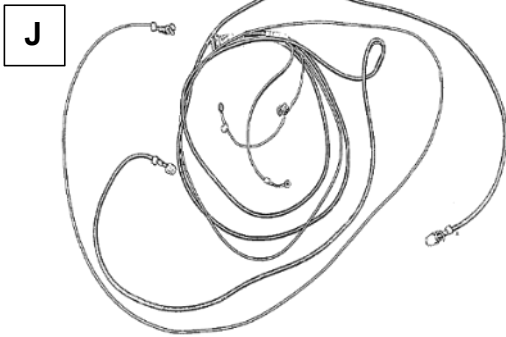

Main Harness

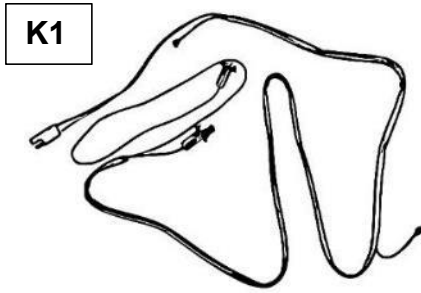

LED Y-Harness (1200mm)

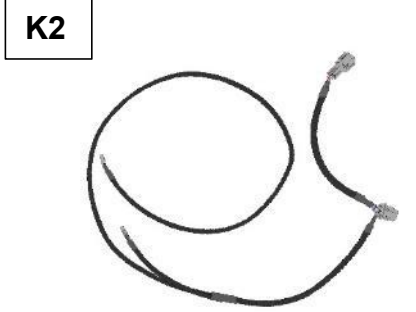

LED Y-Harness (280mm)

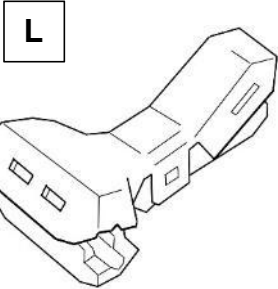

Wire Taps

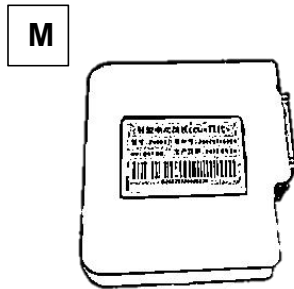



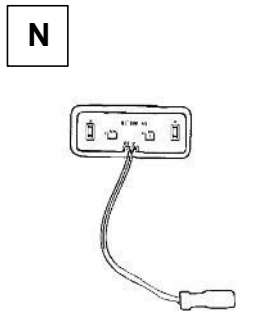

ECU

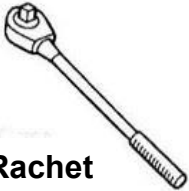

LED Lights

**TOOLS REQUIRED**

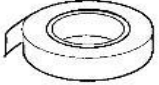
 <p>Ratchet</p>	 <p>8mm 10mm 13mm</p> <p>Socket</p>	 <p>Extensions</p>	 <p>Wrench</p>	 <p>Electrical Tape</p>
--	--	---	---	--

**1A** Locate body frame on underside of vehicle and identify whether there is are OE module plugs or Mass Dampers. Be sure to check both Driver and Passenger Sides. Some vehicles may not have these parts from the manufacturer.

If vehicle has an **OE module plug**, follow **Step 1A**. If vehicle has **Mass Dampers**, follow **Step 1B**. If vehicle does not have an these on front part of body frame, **proceed directly to Step 2**.

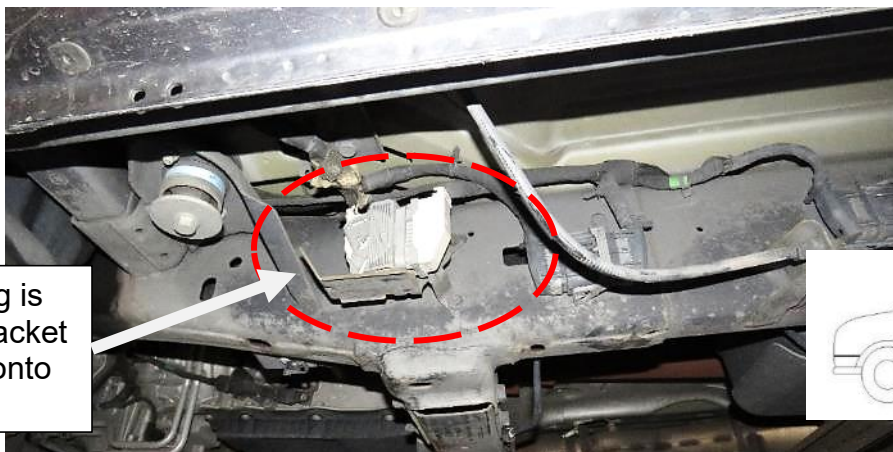

OE Module Plug is attached via a bracket which is bolted onto the frame.

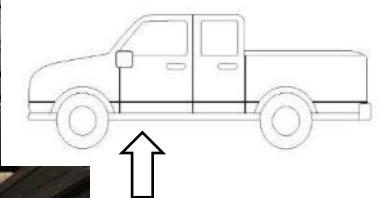

13-18 DODGE RAM 1500 (Incl. 2019 Ram 1500 Classic) & 13-24 DODGE RAM 2500/3500 QUAD CAB/CREW CAB/MEGA CAB  
(Excl. Diesel Chassis Cab Models and models with Air Ride Suspension tanks)

On some vehicles, an OE module plug may be in the way. If so, unbolt the plug's bracket from the frame. Then remove the plug from the bracket. Plug may be located at the front or rear.

OE plug bracket

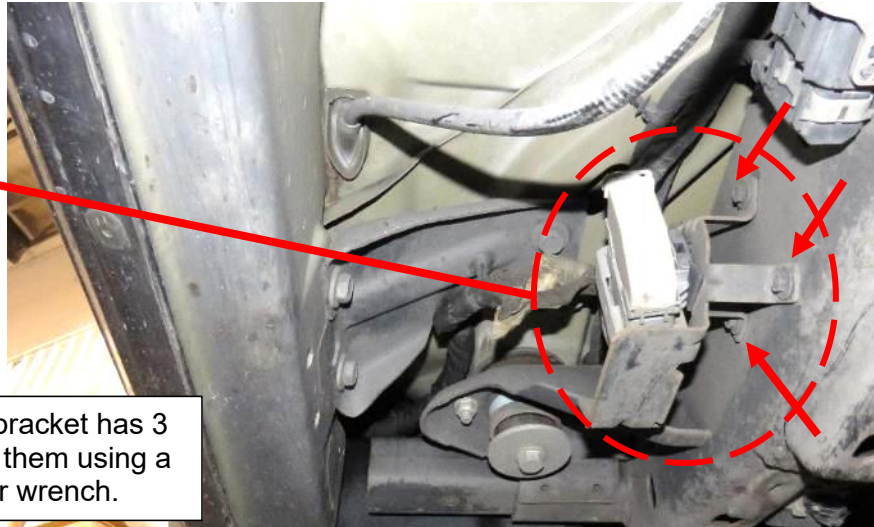
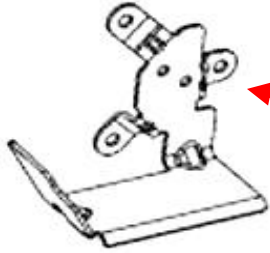

Note: OE plug bracket has 3 bolts. Unfasten them using a 10mm socket or wrench.

Once removed, resecure the plug to the frame out of the way of the components using zip ties.

After removing the plug bracket from the frame, it is recommended to separate the bracket from the plug.

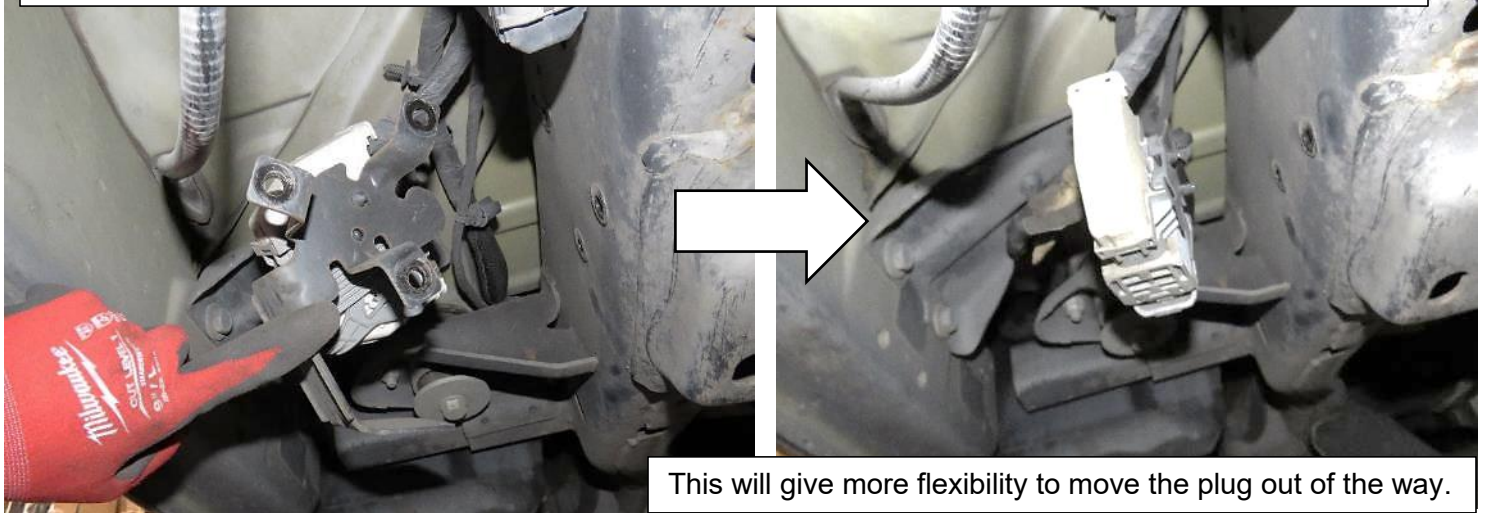

This will give more flexibility to move the plug out of the way.

**1B** Some vehicles may have Mass Dampers attached to the front frame area (commonly found on Quad Cabs). If your vehicle has one, unbolt the Mass Damper and remove it from its frame bracket.

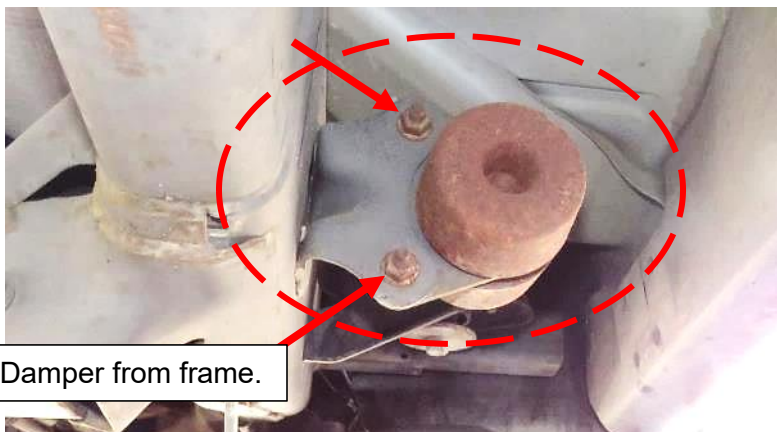

Unbolt Mass Damper from frame.

Next, locate the front mounting area. Determine if the rocker panel has either threaded inserts or has simple hexagonal holes. Follow the step in the black box below:

If vehicle has only hexagonal holes, **follow Step 2A**. If vehicle has threaded inserts, **proceed directly to Step 2B** instead.

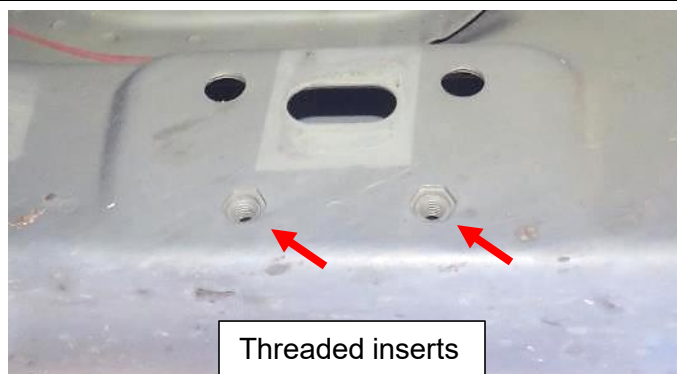
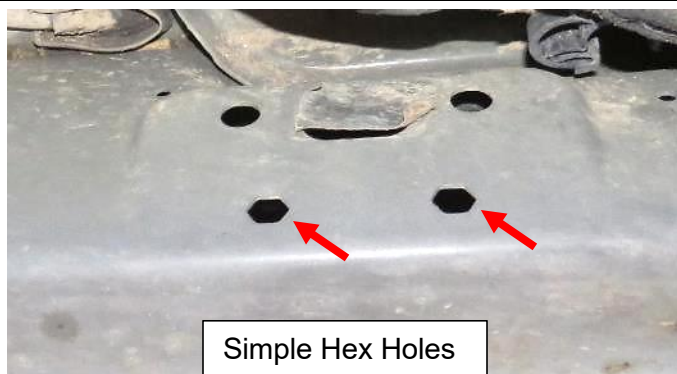

**2A** Take the Bolt-Nut Plate, and thread an M8 Hex Bolt into the nut side of the Bolt-Nut Plate. Stop when the bolt reaches the end of the nut as pictured below.

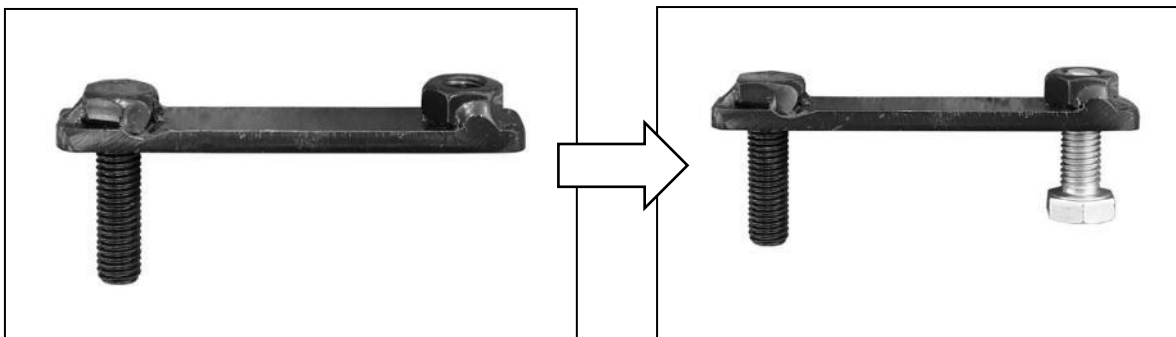

Use the loose Hex Bolt as a handle and insert the Bolt-Nut Plate into the oval hole. **Do NOT let go of the Hex Bolt.** Feed the threaded bolt end of the Bolt-Nut Plate out either factory hex shaped hole. Hold the Bolt-Nut Plate in position using a plastic insulator. Once the plastic insulator is threaded onto the Bolt-Nut Plate, let go of the Hex Bolt handle.

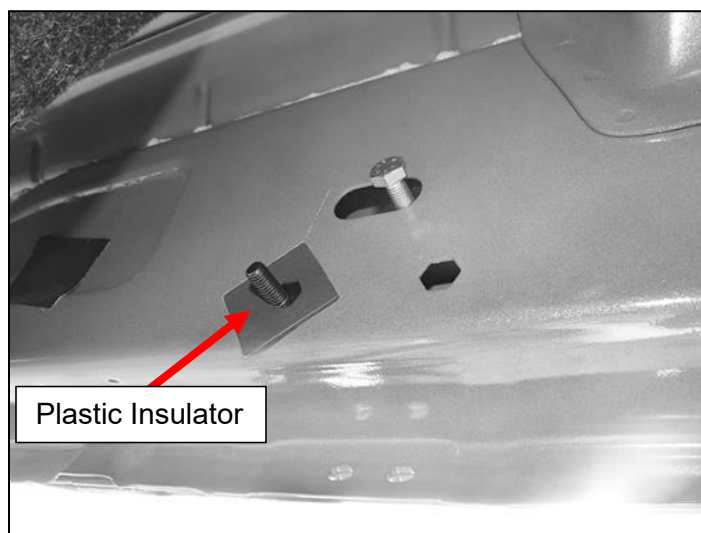
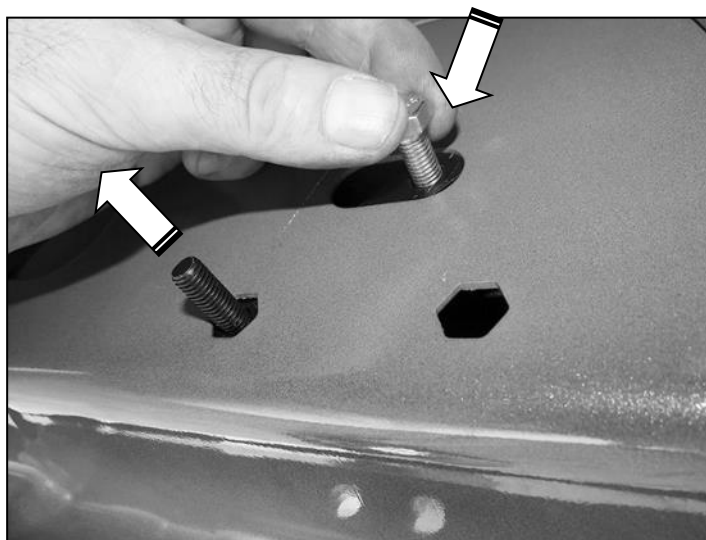

13-18 DODGE RAM 1500 (Incl. 2019 Ram 1500 Classic) & 13-24 DODGE RAM 2500/3500 QUAD CAB/CREW CAB/MEGA CAB  
(Excl. Diesel Chassis Cab Models and models with Air Ride Suspension tanks)

Next, line up front mounting bracket slots to the rocker panel mounting points and place Driver Side/Left Rear Bracket Assembly (A) onto rocker panel. Be sure to remove the temporary Hex Bolt handle from the Bolt-But Plate. The threaded end of the Bolt-Nut Plate should insert through one of the forward slots on the mounting bracket. Then fasten Nylon Lock Nuts (I) and washers (H) onto the threaded bolt. Do not tighten all the way yet.

Example of how threaded end of Bolt-Nut Plate fits to the bracket.

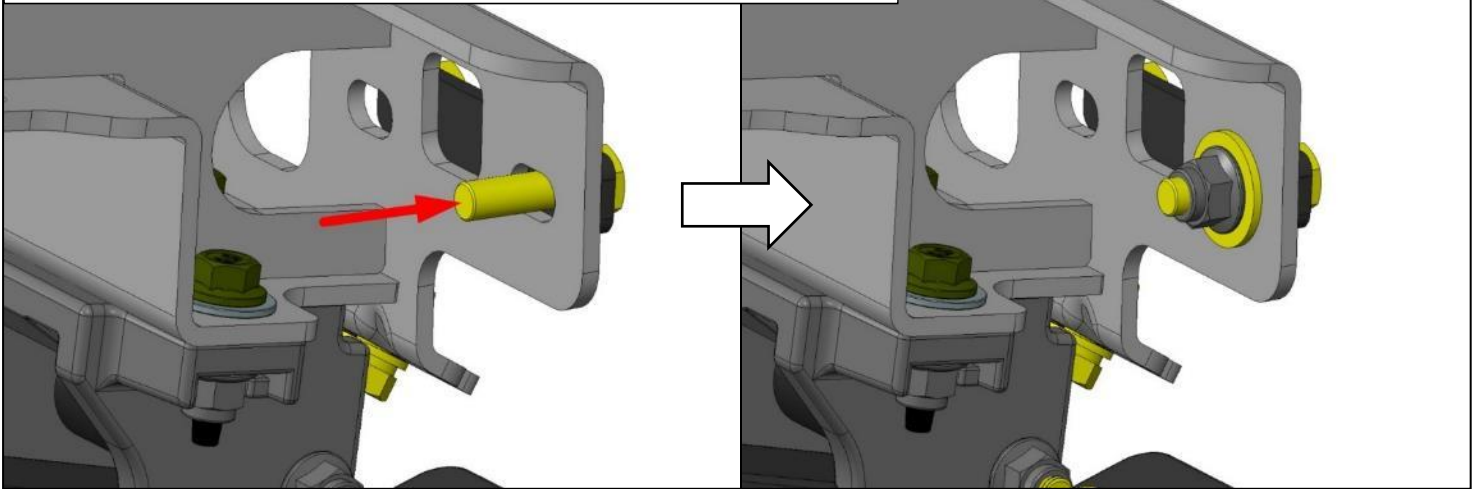

Use the threaded bolt end of the Bolt-Nut Plate to rotate the nut side in-line with the other mounting hole. The Bolt-Nut Plate should be oriented horizontally. Thread the M8 Hex Bolt (30mm length) + M8 Lock Washer + M8 Flat Washer (24mm diameter) into the nut side of the Bolt-Nut Plate to mount the bracket assembly. Hand tighten the mounting hardware until snug.



At this point is recommended that the bracket assembly be mounted tight enough to not fall or shift from its own weight but loose enough to adjust further.

Proceed to step 3.

Locate the front threaded mounting points. Next, line up the front mounting bracket slots to the rocker panel mounting points and place Driver Side/Left Rear Bracket Assembly (A) onto rocker panel. Thread the M8 Hex Bolt (30mm length) + M8 Lock Washer + M8 Flat Washer (24mm diameter) into the two threaded inserts. Do not tighten all the way yet. Hand tighten the mounting hardware until snug.

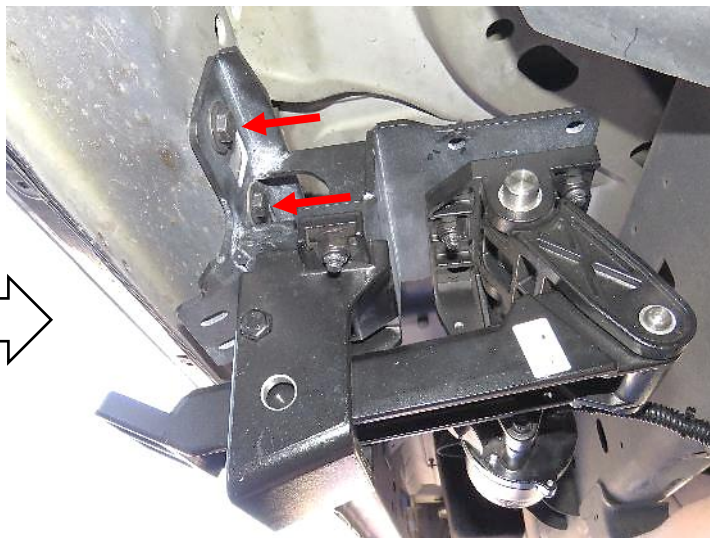

At this point is recommended that the bracket assembly be mounted tight enough to not fall or shift from its own weight but loose enough to adjust further.

Proceed to step 3.

3

Look at the bracket assembly and determine if the bracket is mounted crooked. Adjust the bracket assembly so that the horizontal lines of the linkage arm are parallel to vehicle body. Once the bracket assembly is aligned correctly, fully tighten the mounting hardware.

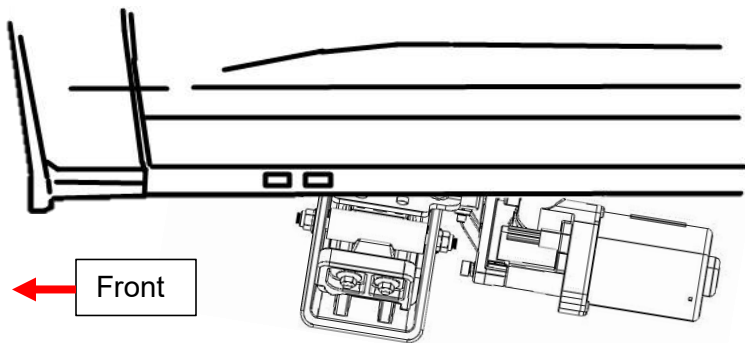

**Bad Alignment**  
to vehicle body.

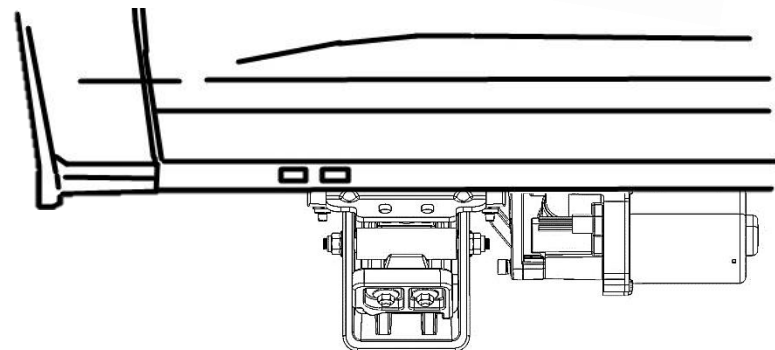

**Good Alignment**  
to vehicle body.

Locate rear mounting points (rearmost on vehicle rocker panel). Repeat either Step 2A or Step 2B depending on the hole or insert style the vehicle has.

For most cab models, the slots on the extended part of the bracket assembly will be used as shown below to avoid interfering vehicle parts. Next, line up rear mounting bracket slots to the studs and place Driver Side/Left Rear Bracket Assembly (B) onto rocker panel. Then fasten Nylon Lock Nuts (I) and washers (H). Do not tighten all the way yet.

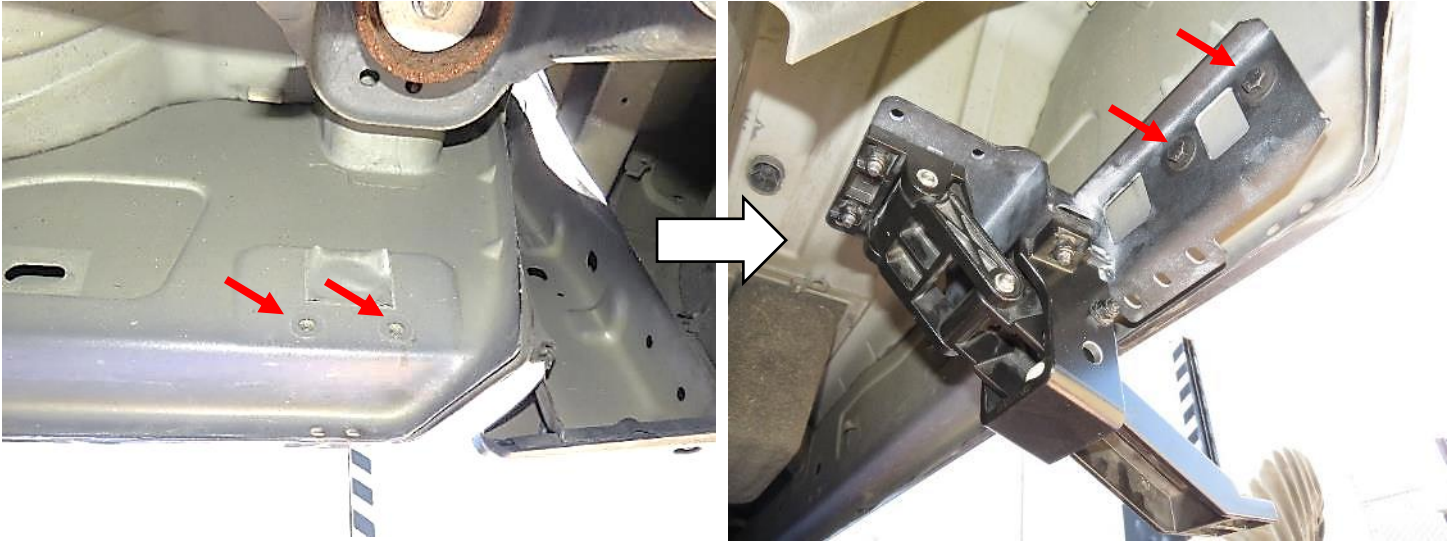

Apply adhesive foam or rubber sleeve where appropriate if vehicle has a brake cable.

Use these mounting slots for Crew and Quad

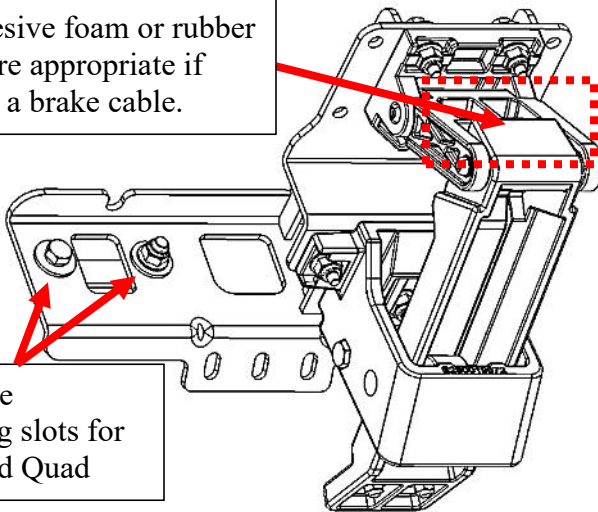

Use these mounting slots for Mega Cab models.

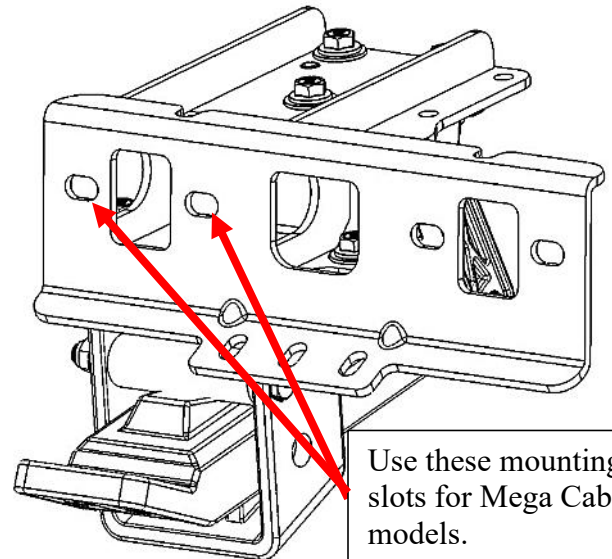

For Mega Cab models, the extended Part of the bracket assembly is not used for mounting. Instead, follow the guide as shown.

Line up the two mounting slots closest to the center of the rear bracket assembly (B).

**Repeat step 3 to check alignment of rear bracket assembly. Then proceed to step 5.**

Rear bracket assembly mounted to Mega Cab



Take the support bracket labeled "DF/PR" (Support Bracket (A)) and attach it to the Driver Side Front Bracket Assembly (A) and the vehicle pinch weld. Thread in the appropriate M6 Hex Bolts (25mm length) + M6 Lock Washers + M6 Flat Washers and use the Double Nut Plate to connect the support bracket to the vehicle pinch weld.

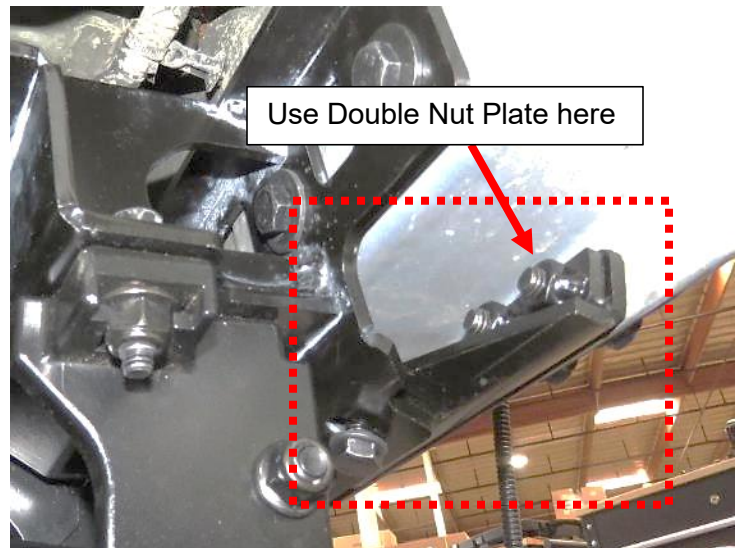
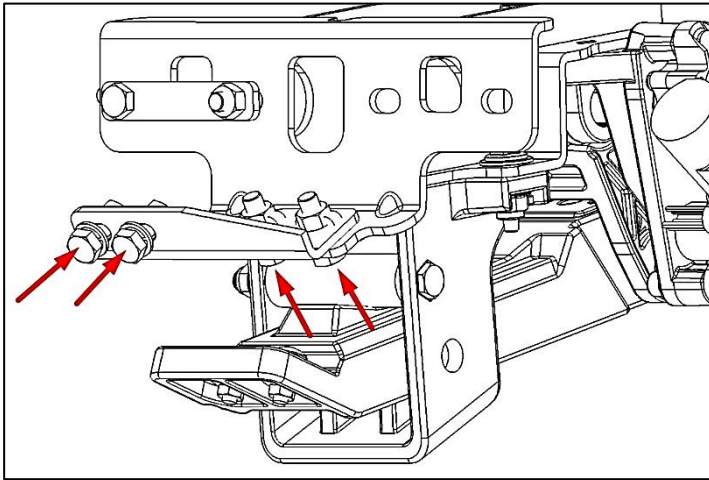

Take the support bracket labeled "DR/PF" (Support bracket (B)) and attach it to the rear bracket assembly using the same process. For Mega Cab vehicles, use Support Bracket A instead.

On Crew and Quad Cabs

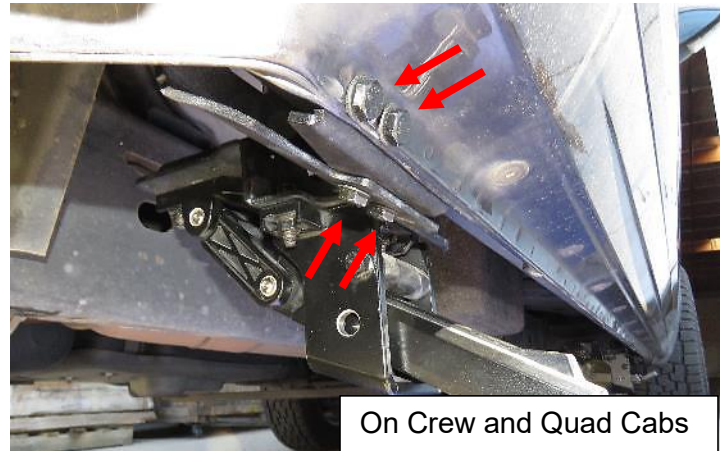
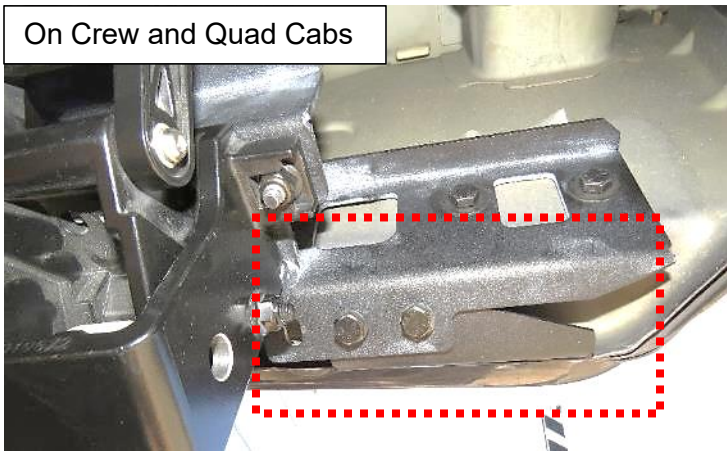

On Mega Cabs

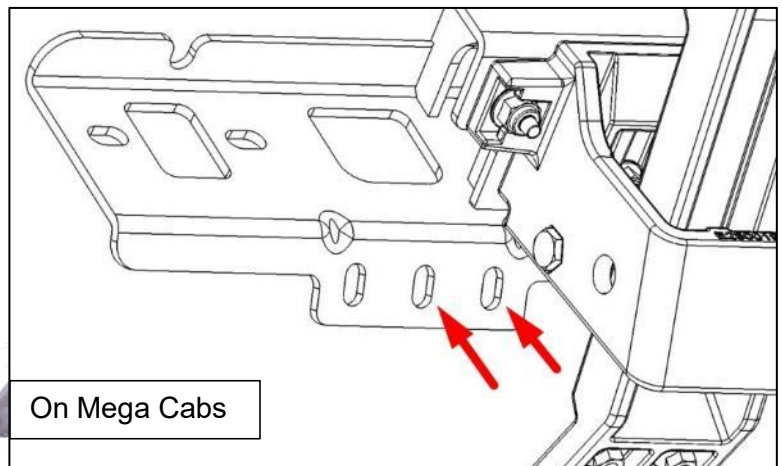
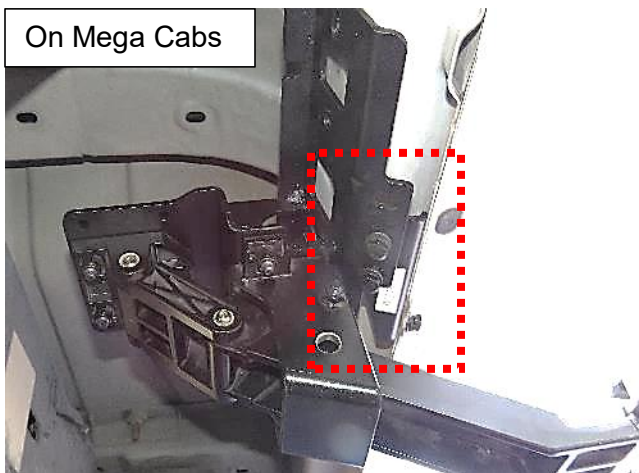



Repeat steps 1 – 2 for the Passenger Side.

- 7** Start from the engine compartment by opening the front hood of the vehicle. Locate the Battery and its terminals (positive/negative). Remove the 25A fuse from the fuse box that comes with the main harness (J).

**\*WARNING:** Keeping the fuse connected to the fuse box may result in electrical sparks and risk of shorting when working with the battery.

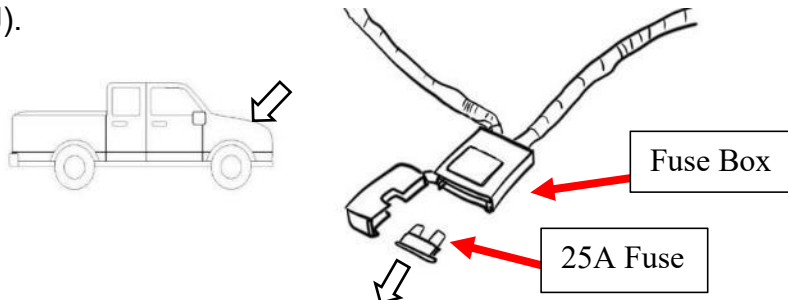

- 8** Connect the positive power lead on the main harness (J) to the positive battery terminal. Connect the negative lead to the negative battery terminal. Make sure both power leads are fully secured. Connect the ECU (M) to the main harness.

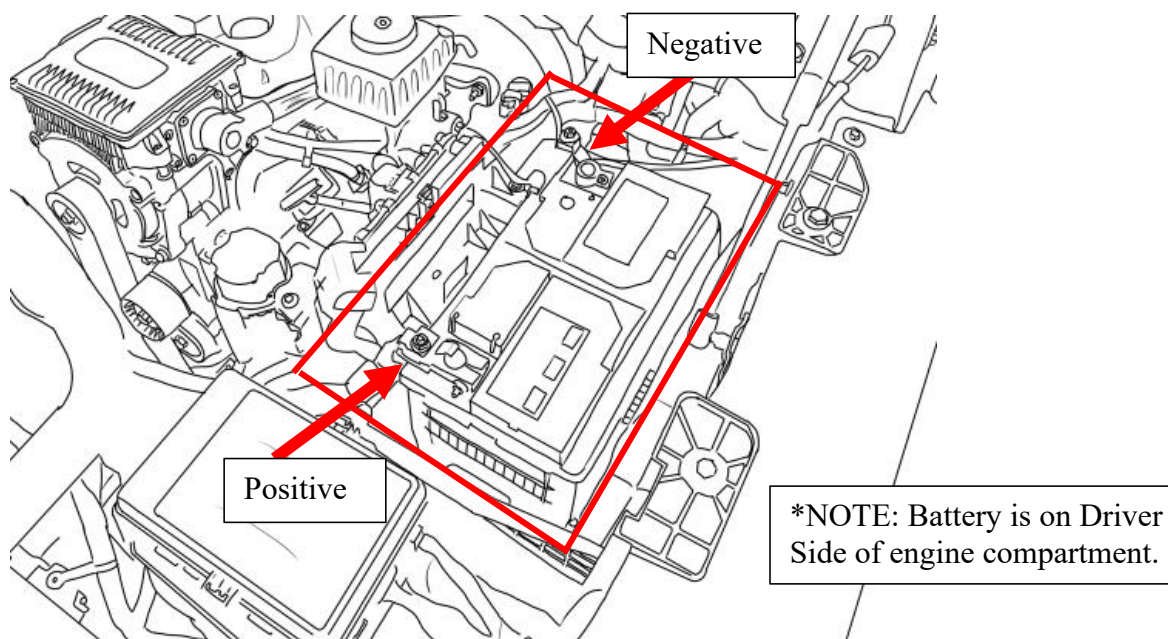

Connect the Long LED Y-Harness (K1) to the Driver-side branch of the main harness.

Connect the Short LED Y-Harness (K2) to the Passenger-side branch of the main harness.

Connect leads before routing main harness legs in next step.

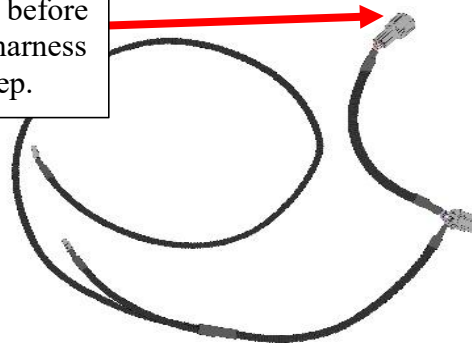

Route the main harness (J) around the battery, up along the rear of the engine compartment. The longer Driver-side branch of the main harness must route down the backside, against the fire wall, and down past the steering column towards the vehicle frame. **Be sure to avoid contact with the steering column.**

Route the shorter (marked "Passenger-side") leg of the harness down the Passenger-side wheel well. **Be sure to avoid contact with any moving or hot engine components.** Attach and secure the main harness (J) with supplied cable ties.

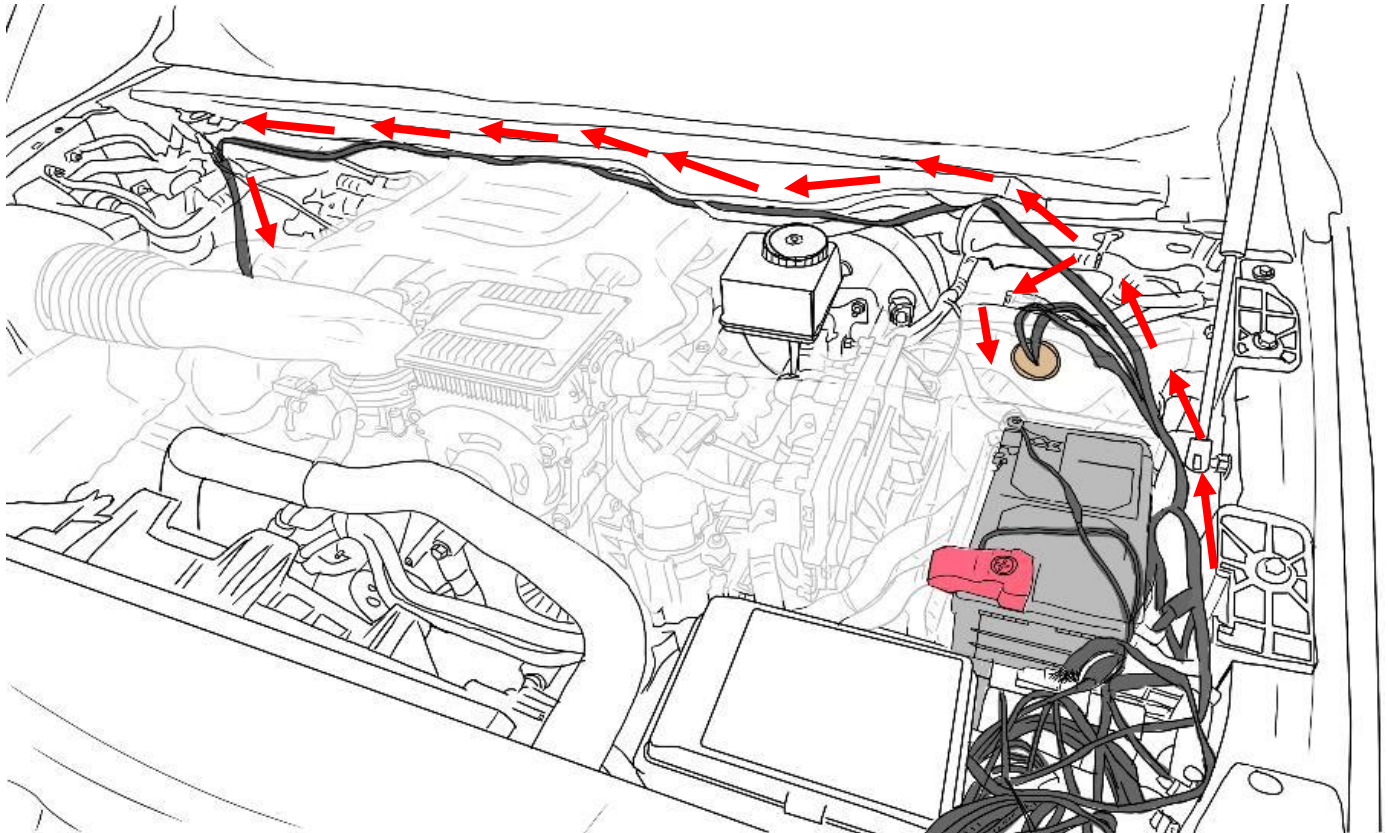

Route the CAN signal (has 2 wires with labels "High" & "Low") branch of the main harness through the double-sided rubber boot against the backside of the engine bay. The boot can be clearly seen from the inside of the cabin. **Be sure to avoid contact with the steering column.**

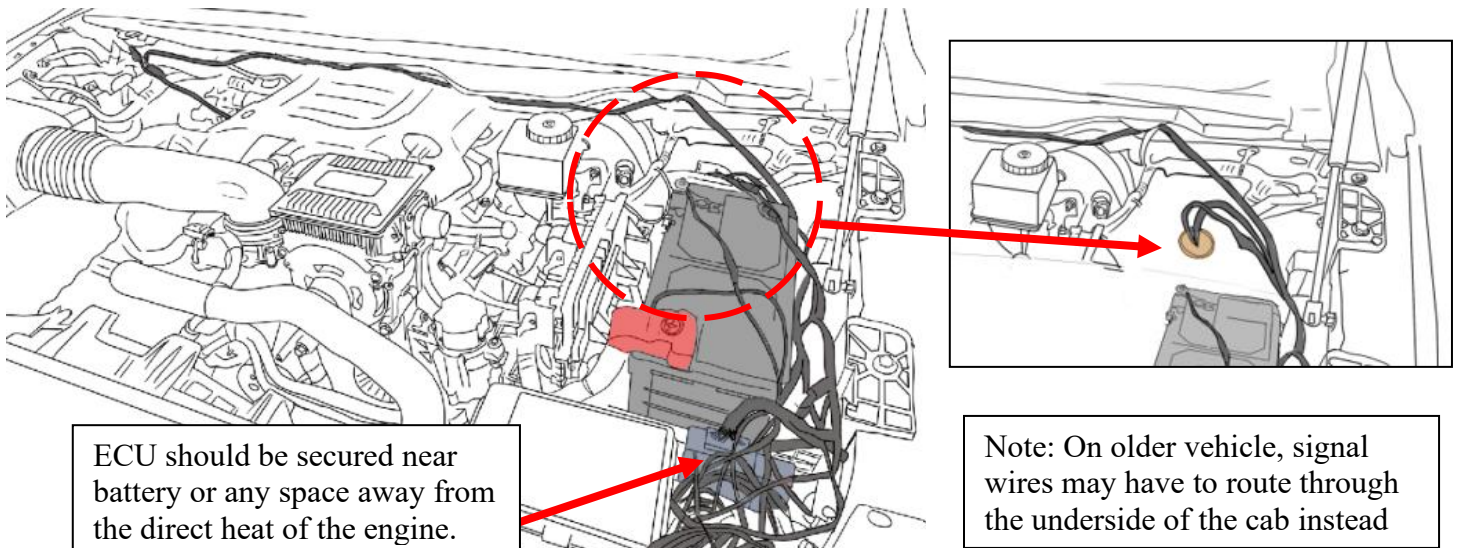

ECU should be secured near battery or any space away from the direct heat of the engine.

Note: On older vehicle, signal wires may have to route through the underside of the cab instead

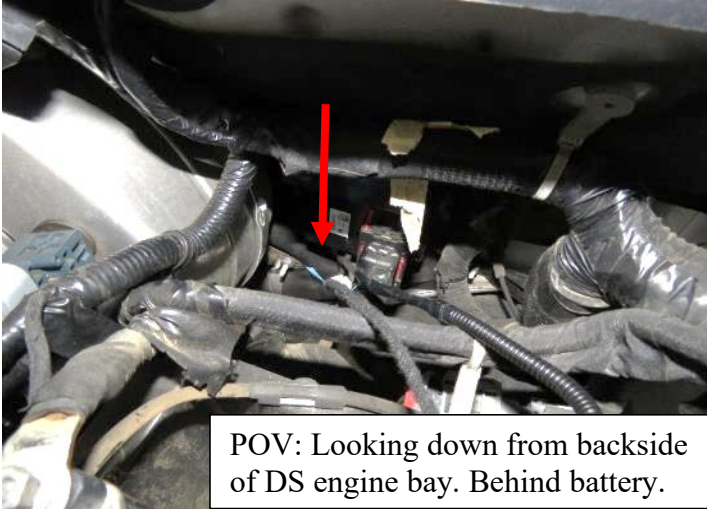

POV: Looking down from backside of DS engine bay. Behind battery.

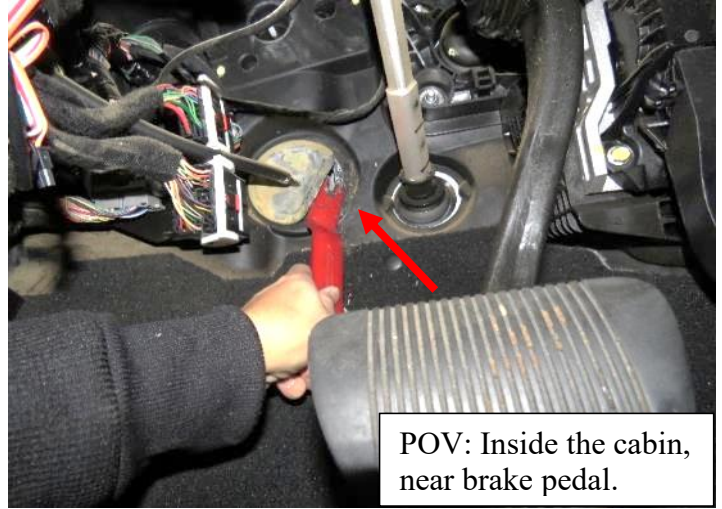

POV: Inside the cabin, near brake pedal.

Inside the cabin, the rubber boot access is located under the steering wheel, behind the brake pedal. A pry-tool is recommended when peeling back the boot flap from the inside of the cabin.

**10**

Route the Driver Side motor branch of the main harness (J) through the engine bay and **behind the Driver-Side wheel well liner**, then to the Drive-side frame.

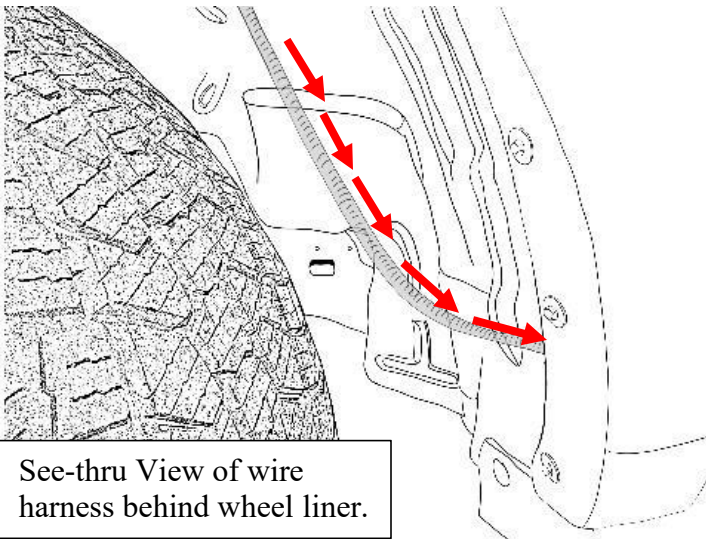

See-thru View of wire harness behind wheel liner.

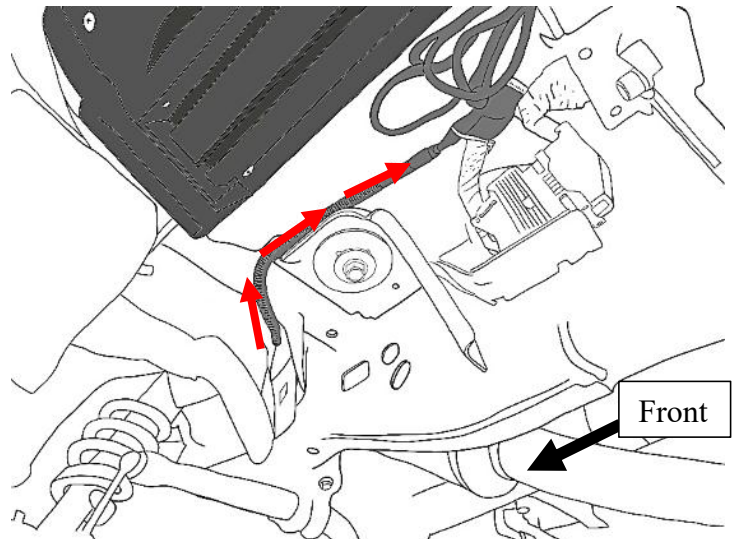
**11**

After routing all branches of the Main Harness (J), check to make sure the wires are secure with cable ties. **Be sure to avoid contact with any moving or hot engine components.** When routing wires through the wheel well area, **it is important to avoid the vehicle suspension.**

If vehicle year is **2019-2024** (Excluding 19 classic), proceed to **step 12A**. If vehicle year is **2013-2018** (Including 19 classic), proceed to **step 12B** instead.

the side of the dash panel on with the front driver side door open. Carefully peel the weather strip from the door seams and use a pry tool to remove to the side dash panel.



Locate the green CAN wiring hub on the backside of the metal framework. Carefully remove the entire black plastic casing (with the green wiring hub attached) by pulling it up. On some models a plastic detent may need to be pressed to unhook the plastic casing from the metal bracket. Carefully pull the plastic hub out of the side cavity for ease of reach.

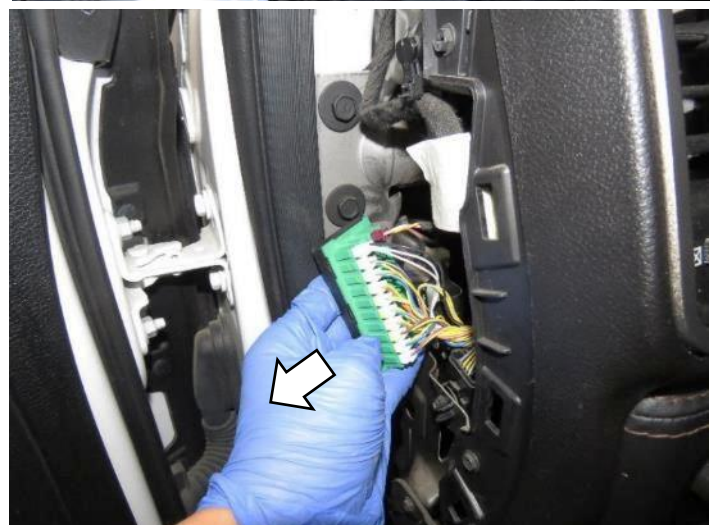
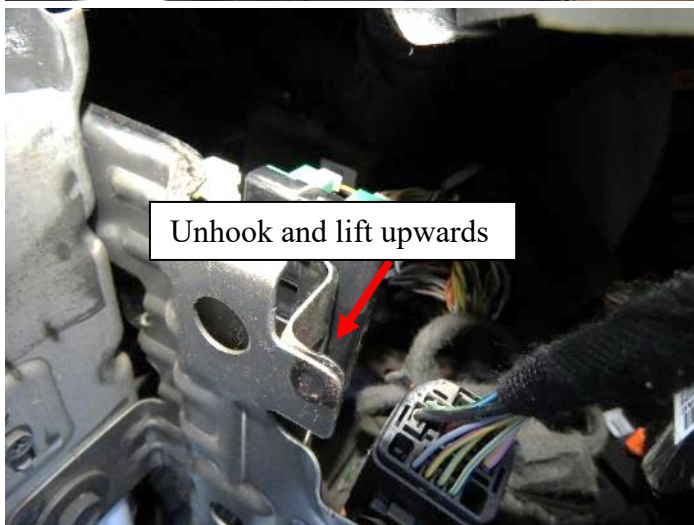
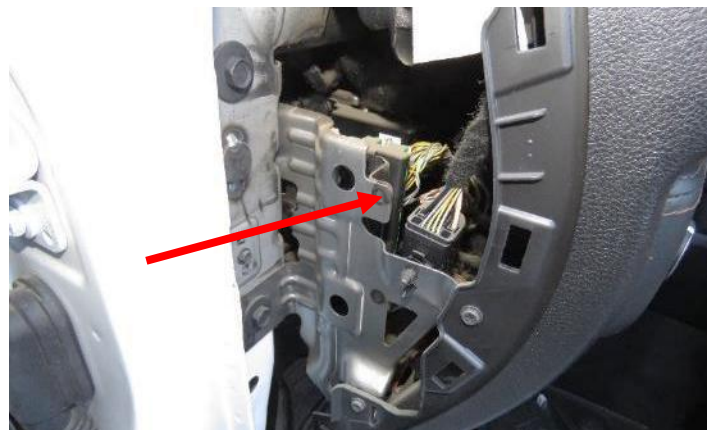

13-18 DODGE RAM 1500 (Incl. 2019 Ram 1500 Classic) & 13-24 DODGE RAM 2500/3500 QUAD CAB/CREW CAB/MEGA CAB  
 (Excl. Diesel Chassis Cab Models and models with Air Ride Suspension tanks)

Identify the configuration of the plugs on the CAN Bus hub. On the row with empty slots, select the closest plug with two wires extending from it. The wire closer to the center of the hub is the CAN High wire. The wire further towards the outer edges is the CAN Low wire.

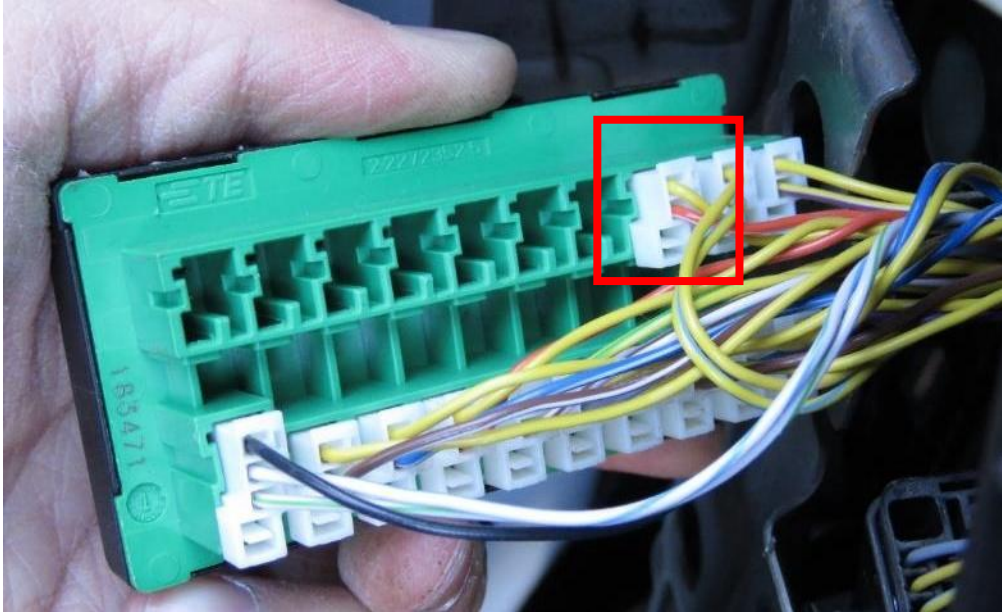

Confirm that the truck is powered off. Connect the High and Low wires from the main harness (J) using the supplied wire taps (L). After successfully connecting the wires, return the module back into its place and check that it is secure on the bracket.

\*NOTE: Some colors may differ from vehicle to vehicle. It is recommended to always use the OE plug as a reference point when identifying the CAN High and CAN Low wires.

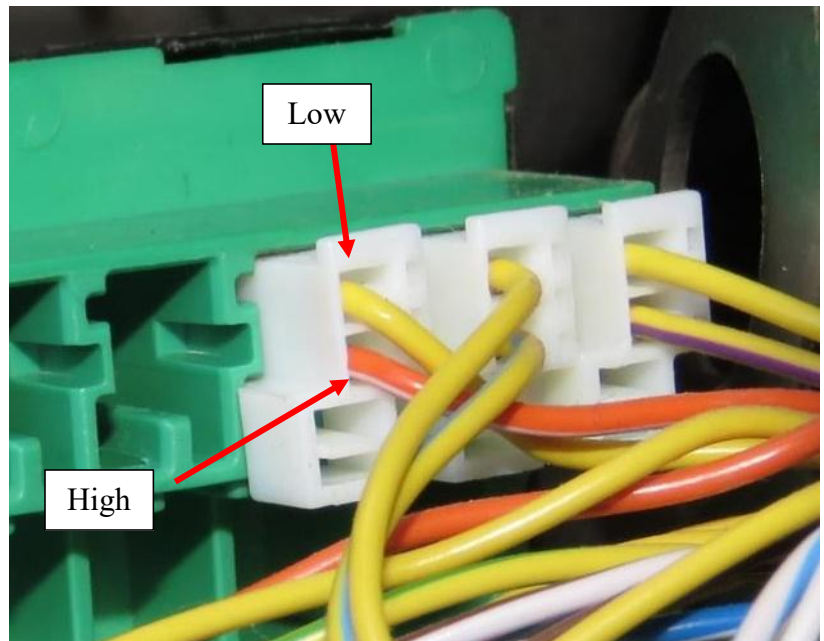

Factory CAN Wire	Main Harness wire color
Yellow (CAN-L)	Yellow (Low)
Orange w/ White Stripe (CAN-H)	White (High)

\*NOTE: Vehicles will often have different colored wires on the plugs. If the indicated wire colors are not present, tap any of the pairs of wires on the upper row.

Wire taps supplied with kit.  
 Please see page 15 for guide.

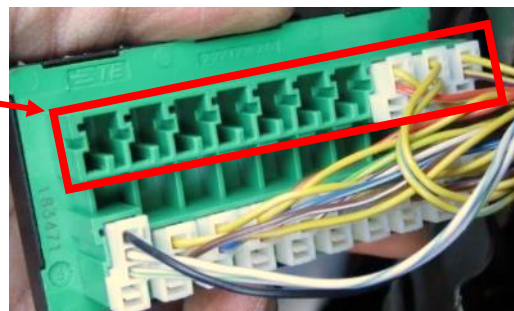

On the Driver Side (under the steering wheel, near the kick panel), locate the wires behind the OBD-II Connector.



Connect the High and Low wires from the main harness (M) using the supplied wire taps (O). Identify wires from back of the OBD-II Connector. Unbuckle the OBD-II Connector for easier access to the wires.

**OBD-II Connector Pin Layout**

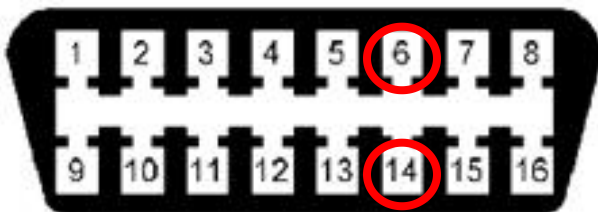

Find and use wire taps on corresponding wires for Pin 6 and 14 on backside of OBD.

Pin 6 = CAN-H  
Pin 14 = CAN-L

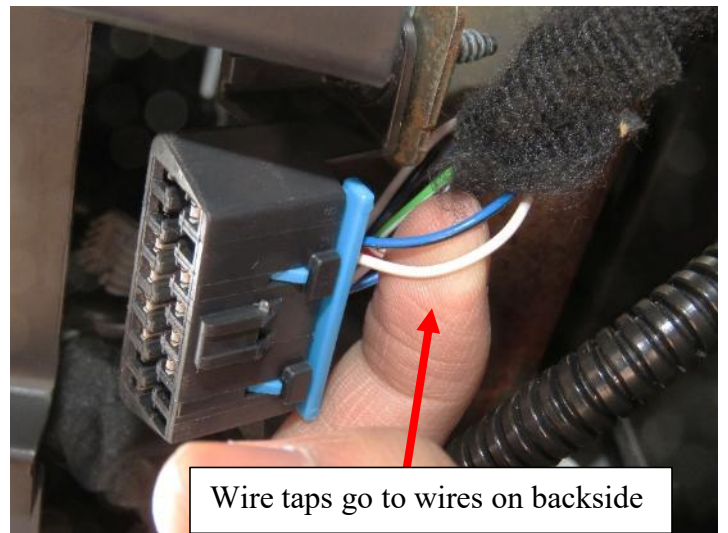

Wire taps go to wires on backside

\*NOTE: On some vehicles, wires may have different colors than depicted here.

NOTE: Wire taps supplied with kit. Please see page 15 for guide.

Factory CAN Wire	Main Harness wire color
3rd from right (lower), Pin 14	Yellow (Low)
3rd from right (upper), Pin 6	White (High)

After successfully connecting the wires, return the connector back into its place and secure the wiring out of the way of the brake pedal and other important instruments.

The kit comes supplied with wire taps called “shark taps”. Follow the guide below to tap the wire using the “shark tap”:

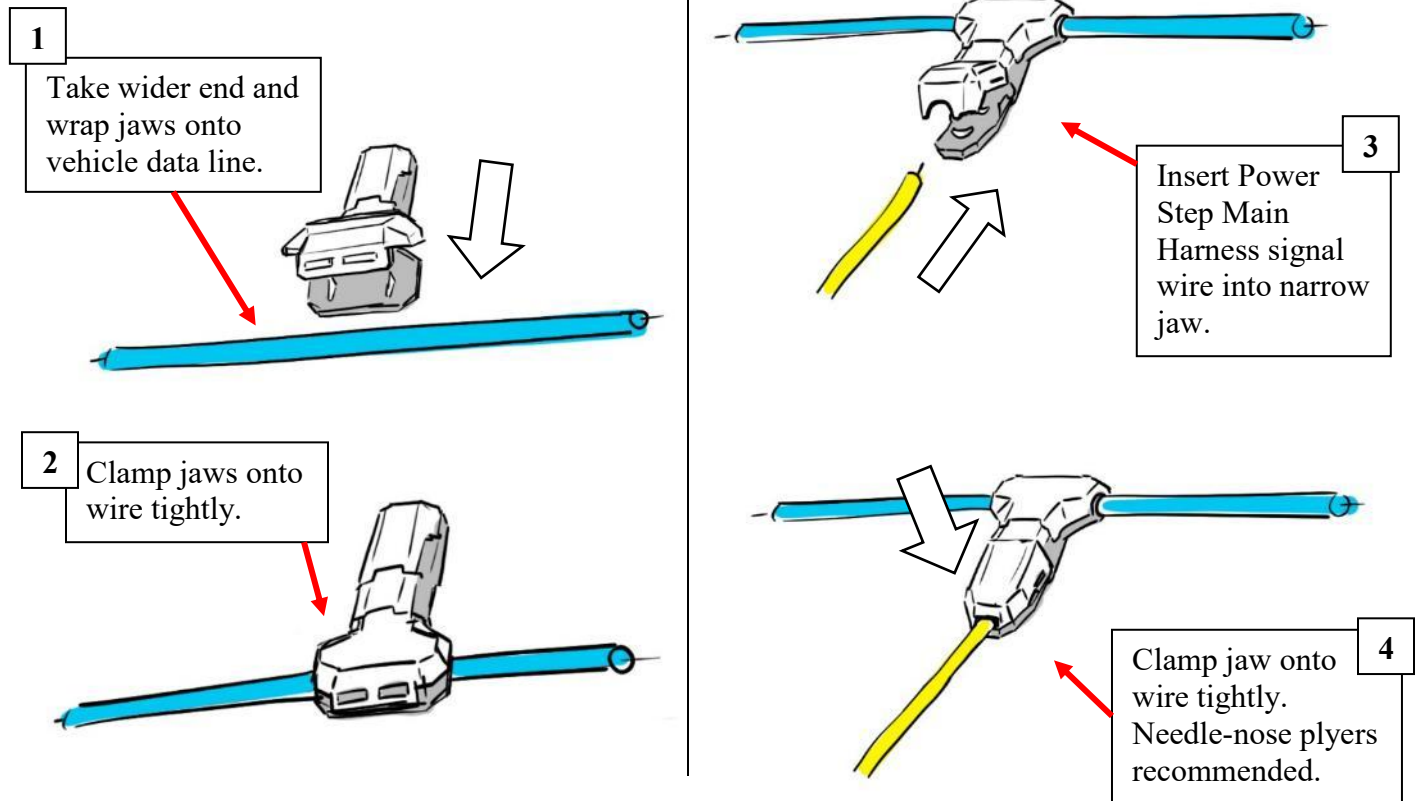

**13** Be sure the main harness (J) is connected to the appropriate length LED Y-Harness (K). Then attach the LED Y-Harness (K) to the motor on the Driver Side. Repeat for Passenger Side.

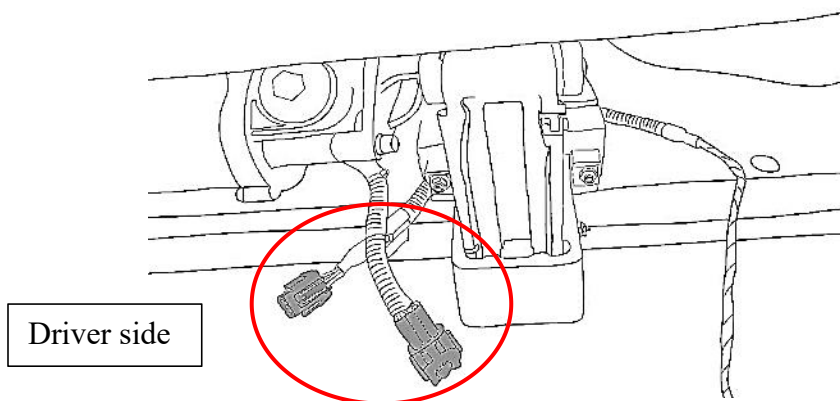

Plug in LED lights (N) into LED Y-Harness (K) and attach them to the bottom of the rocker panel. Use provided 3M double sided adhesive tape on back of LED light (N). Replace Fuse into Fuse Box.

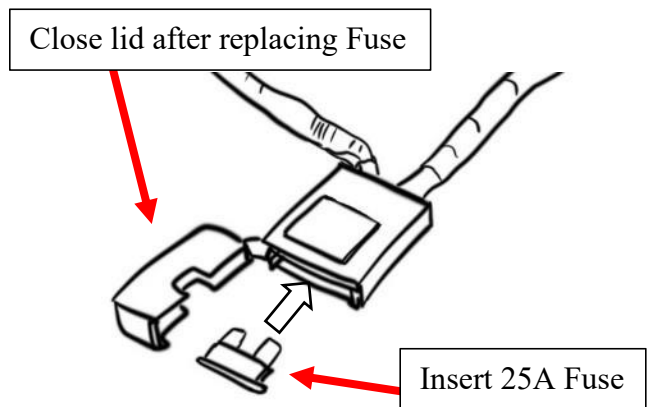
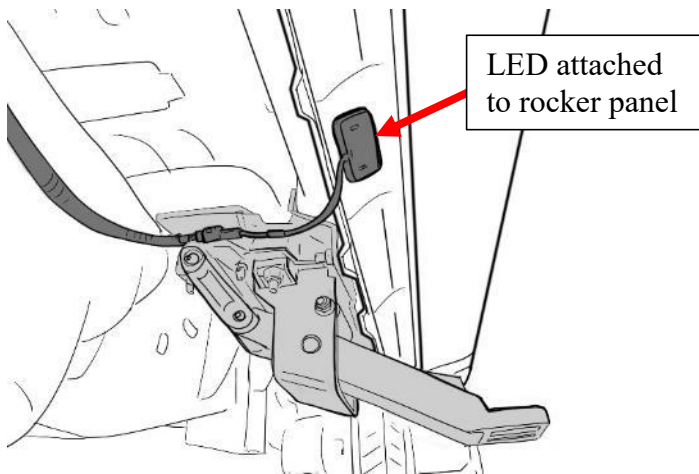

## 15

Check to make sure the harnesses on the Driver Side/Left Front Bracket Assembly (A) and Passenger Side Front Bracket Assembly (C) are connected to the main harness (J) via the LED-Y harnesses (K).

\*NOTE: The linkage arms on the front bracket assemblies will not move unless both motors are connected.

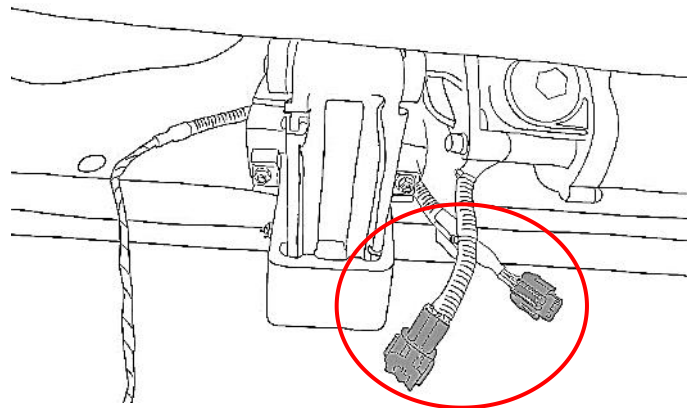

## 16

Seal the rubber boot with RTV Silicone Sealant if needed.

Hide wires and reattach the interior panels with the carpet fully unfurled in its original position. Reattach the door sill weather strip.

Check to make sure there are no obstructions or potential snag points around the brake pedal area.

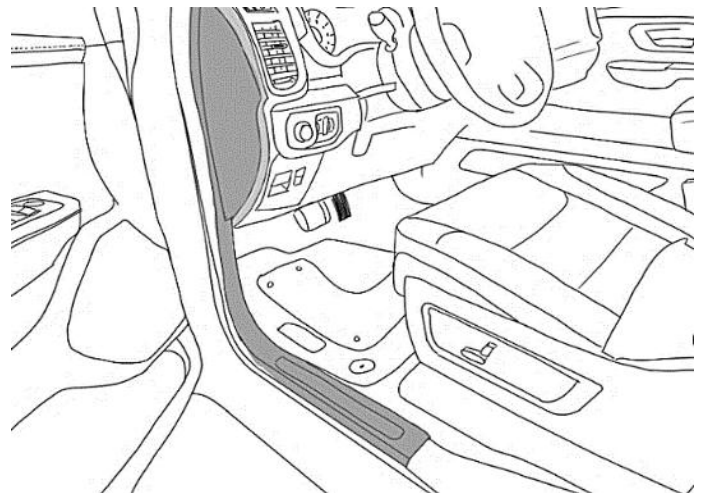



- 17** Prepare the power step boards. Locate the end of the boards and slide the M6 Carriage Bolts (E) into the channel on the underside of the board. Insert a total of 4 carriage bolts (E).

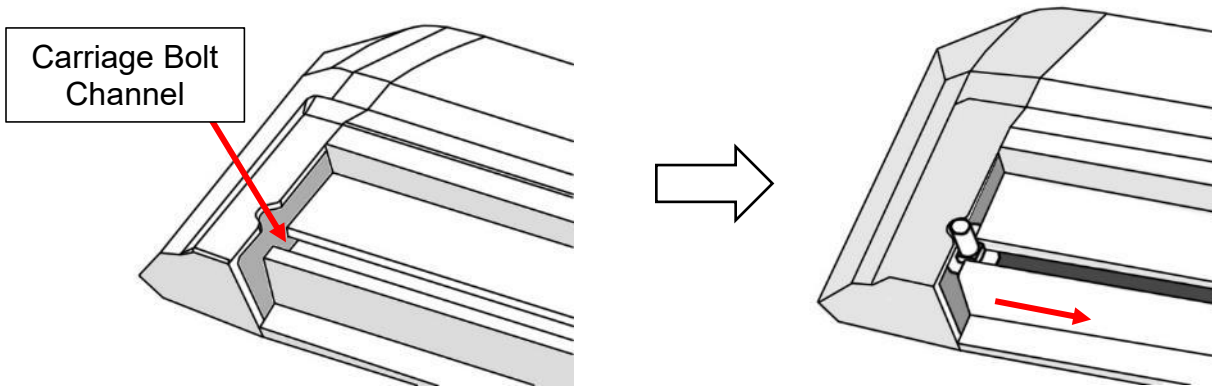

Use the notch in the board's end caps to feed the bolts into the channel.

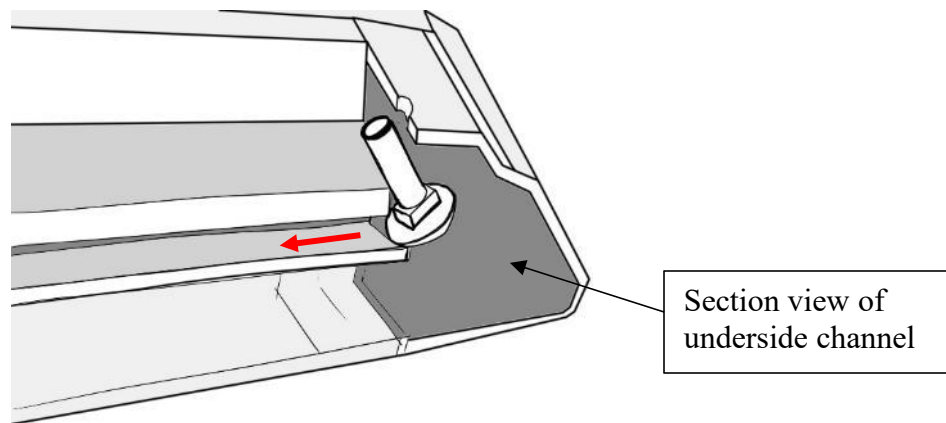

- 18** Perform a function check by closing the driver side front door and opening it again. The front bracket assembly (A) motor should activate the linkage arm and move it into the down or "deployed" position.

After deploying linkage arms, unplug main harness connector while front door is open to hold the board in the deployed position for running board installation.

Line up the carriage bolts (E), under the power step boards, with the slots on the linkage arms (A & B). Insert the 4 carriage bolts (E) into the slots on front and rear linkage arms. Adjust board to desired position. Moderately hand tighten the flange nuts (G) onto the carriage bolts.

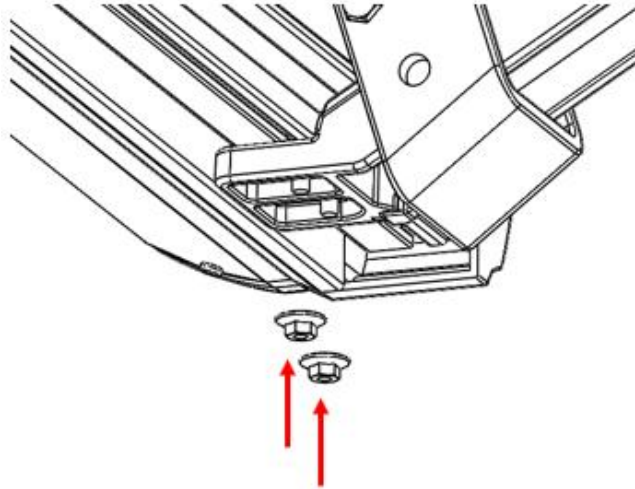

\*NOTE: May need to loosen support brackets to adjust bracket assemblies.

Once the board is adjusted, plug in main harness (J) connector to return power to the linkage arms. Open and close doors several times to deploy and retract the steps to settle the steps into their natural alignment. After cycling the step, tighten all hardware on the board and brackets.

Some further adjustment may be required for desired step position. Repeat for passenger side.

## 19

Perform system check and troubleshooting. If board is making irregular movements or noise, readjust the boards as follows:

- a) With board deployed loosen 6mm flange nuts under board.
- b) Leave the flange nuts slightly less than snug.
- c) Open and close door several times for board to settle into position.
- d) With the step in the deployed position, gradually tighten flange nuts while alternating between each. Do not over tighten.

If board is making abnormal noise or the motion is binding, repeat steps “a” through “d”.

Note: If the above method does not resolve the issue, the brackets mounting to the vehicle may not be aligned properly with the vehicle. In this case, remove the board and realign brackets before attempting steps “a” to “d” once again. Reinstall any remaining trim panels if necessary. Check and make sure all hardware is fully tightened. Perform a final system check. Finish.

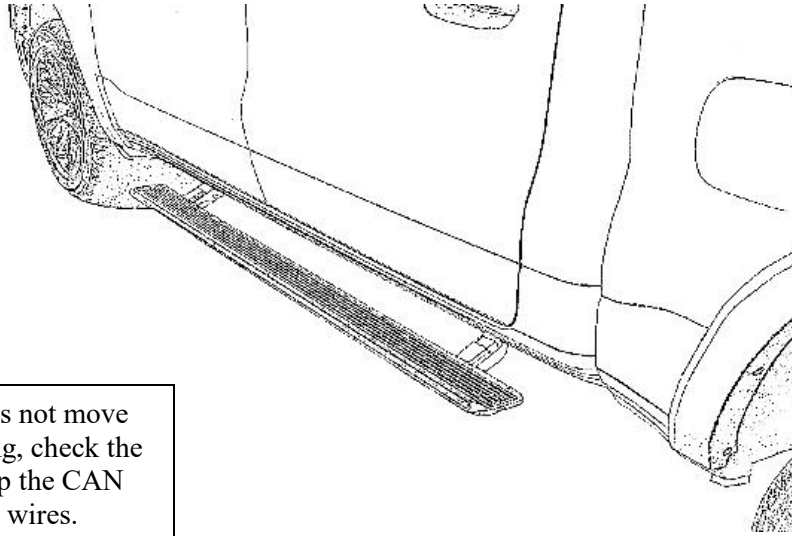

\*NOTE: If board does not move during troubleshooting, check the tap connections or flip the CAN Signal High and Low wires.

\*NOTE: May need to loosen support brackets to adjust bracket assemblies.

\*NOTE: May need to check to see if bracket alignment is correct (see step 3).