

iBoard®



Scan for
Installation Video

iBoard® by APS

PART#: IB-K406

READ INSTRUCTIONS CAREFULLY BEFORE STARTING INSTALLATION. REMOVE CONTENTS FROM BOX AND VERIFY ALL PARTS ARE PRESENT. ASSISTANCE IS RECOMMENDED.

*ROCKER PANEL MOUNT
*NO DRILLING REQUIRED

Fastener Size	Tightening Torque (ft-lbs)	Required
6mm	6-7	√
8mm	16-18	X
10mm	31-32	X
12mm	56-58	√
14mm	92-94	X

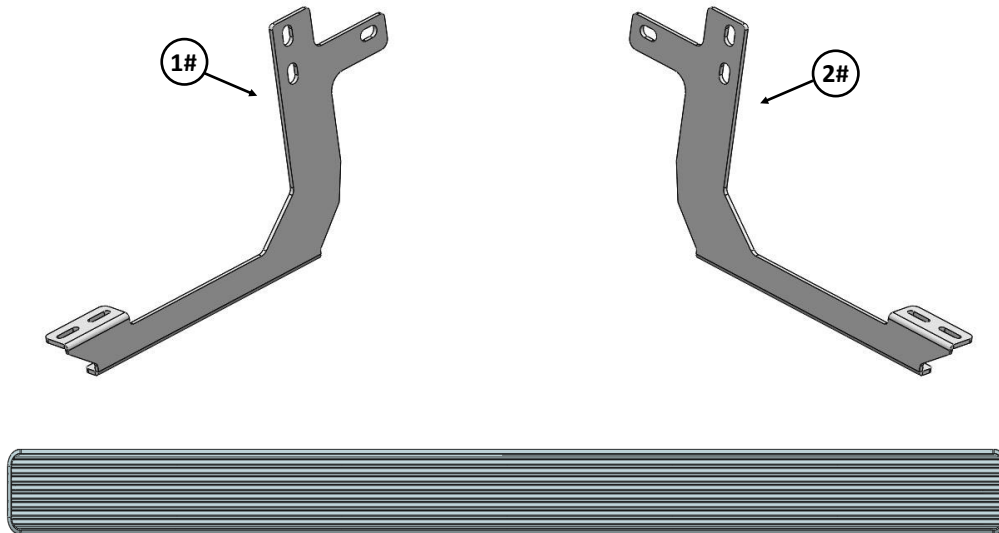

Front
↑





Customer Support: info@iboardauto.com

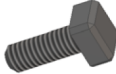

Mounting Bracket List					
Item	QTY	Description	Item	QTY	Description
1#	1	Driver Side Mounting Bracket	2#	1	Passenger Side Mounting Bracket

Hardware Package A (For Bracket Installation)					
Item	QTY	Description	Item	QTY	Description
1#	6	M12X1.75-100mm Hex Bolts	3#	6	M12 Nylon Lock Nuts
2#	12	M12 Large Flat Washers			
 1#  2#  3#					

Hardware Package B (For Aluminum Step Bar Installation Only, Not Supply to SS. Step Bar)					
Item	QTY	Description	Item	QTY	Description
1#	4	M6X1-20mm Square Head Bolts	3#	4	M6 Nylon Lock Nuts
2#	4	M6 Large Flat Washers			
 1#  2#  3#					



WARNING: ALLOW TIME FOR THE MUFFLER TO COOL COMPLETELY BEFORE INSTALLING REAR BUMPER GUARD BRACKETS.

STEP 1

Start the installation under the driver side, rear of the vehicle, (Fig 1). Locate the (3) mounting holes in the frame.

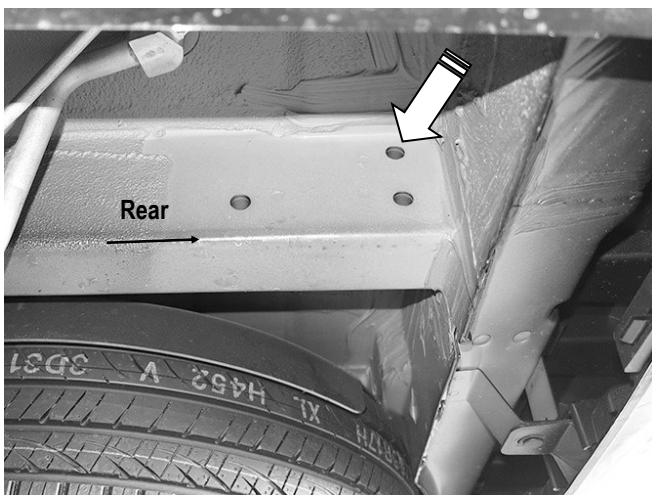

(Fig 1) Driver Side Mounting Location

STEP 2

Select the Driver Side Mounting Bracket. Attach the Bracket to the outside of the frame with the included (3) M12X1.75-100mm Hex Bolts, (6) M12 Large Flat Washers and (3) M12 Nylon Lock Nuts, (Figs 2 & 3). Do not fully tighten hardware at this time.

STEP 3

Repeat **Steps 1-2** to install the passenger side Mounting Bracket.

(3) M12X1.75-100mm Hex Bolts
(6) M12 Large Flat Washers
(3) M12 Nylon Lock Nuts

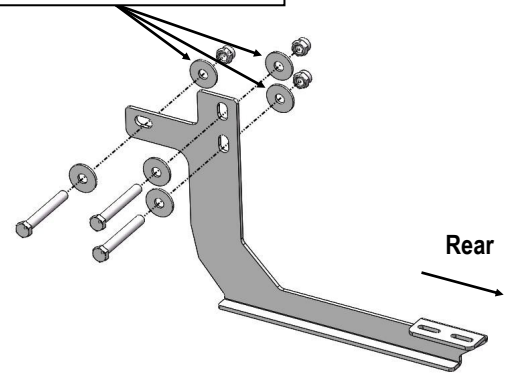

(Fig 2) Driver Side Mounting Brackets Installed



(Fig 3) Driver Side Mounting Brackets Installed

STEP 4

Select a Step Bar. Slip (2) M6x1-20mm Square Head Bolts into each bottom channel (Fig 4). Carefully position the Step Bar onto the (2) Mounting Brackets.

IMPORTANT: Do not slide the Step Bar on the Brackets or the bottom surface of the board will be damaged. Attach the Step Bar to each Mounting Brackets with (2) M6x1-20mm Square Head Bolts, (2) M6 Large Flat Washers and (2) M6 Nylon Lock Nuts, (Fig 5). Do not fully tighten at this time.

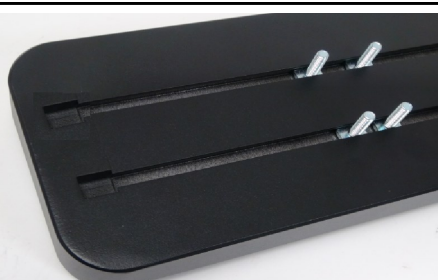

(Fig 4) Slip M6X1-20mm Square Head Bolts Into The Bottom Channels

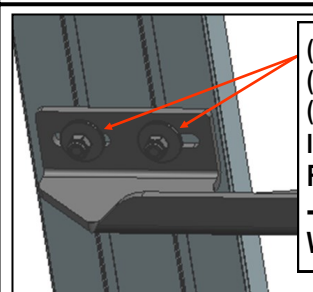

(2) M6X1-20mm Square Head Bolts
(2) M6 Large Flat Washers
(2) M6 Nylon Lock Nuts
IMPORTANT: TORQUE FOR 6MM FASTNERS MUST LESS THAN 6 -7 FT-LBS OR THE FASTNERS WILL BE DAMAGED!

(Fig 5) Step Bar Installed Onto Mounting Bracket

STEP 5

Level and adjust the Step Bar and fully tighten all hardware.
The installation is completed!!!

Attention

Do periodic inspections to the installation to make sure that all hardware is secure and tight.
In order to protect your bars/boards, please use mild soap/non-abrasive products for cleaning only.