

iBoard®

iBoard® by APS

PART#: IB-R060H_Y

READ INSTRUCTIONS CAREFULLY BEFORE STARTING INSTALLATION. REMOVE CONTENTS FROM BOX AND VERIFY ALL PARTS ARE PRESENT. ASSISTANCE IS RECOMMENDED.

*ROCKER PANEL MOUNT
*DRILLING IS REQUIRED

Fastener Size	Tightening Torque (ft-lbs)
6mm	6-7
8mm	16-18
10mm	31-32
12mm	56-58
14mm	92-94

PART LIST

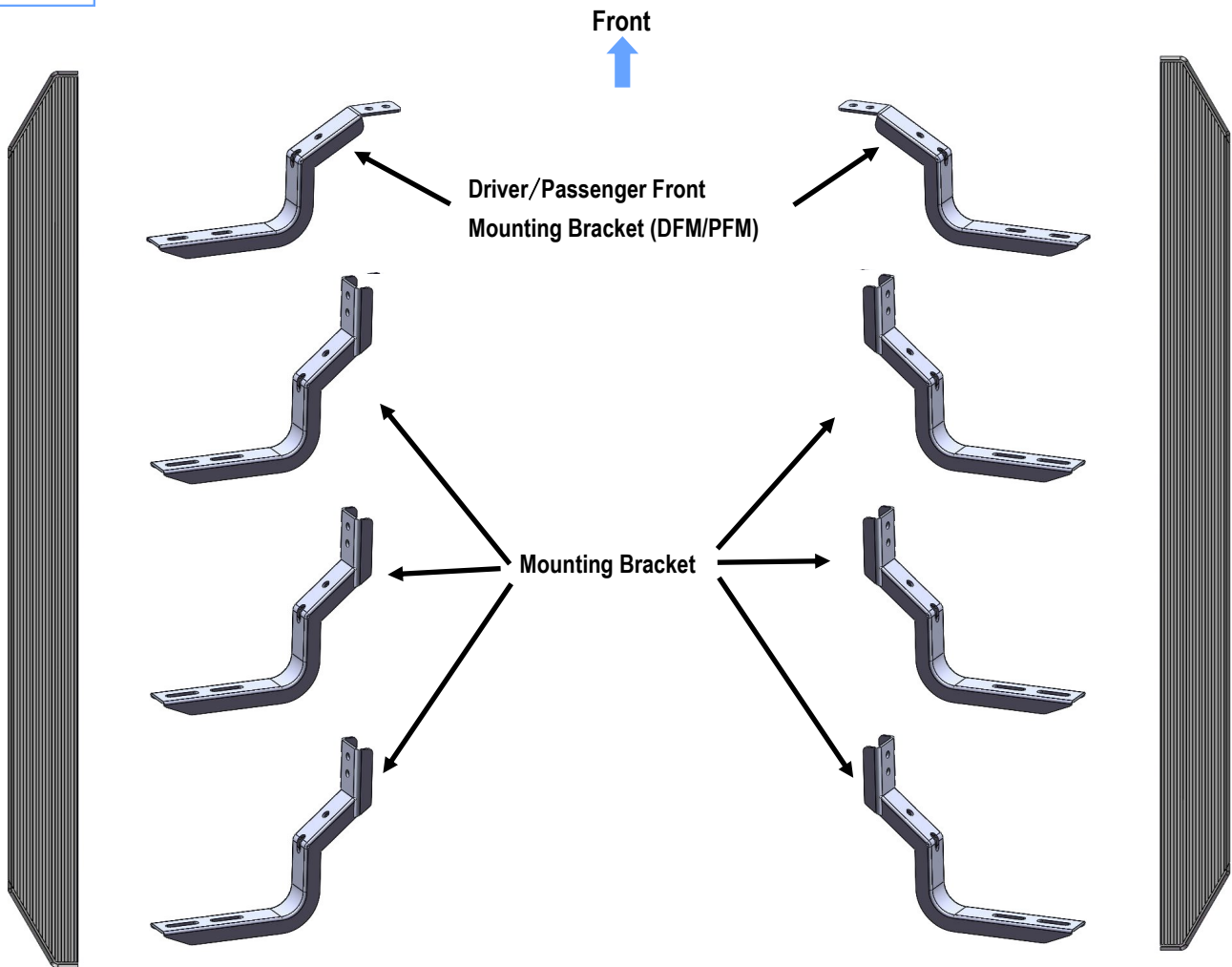

Customer Support: info@iboardauto.com

iBoard®



STEP 1

Start installation from the passenger side of the vehicle. Drilling 5/16" holes in pinch weld as show, (See Fig 1).

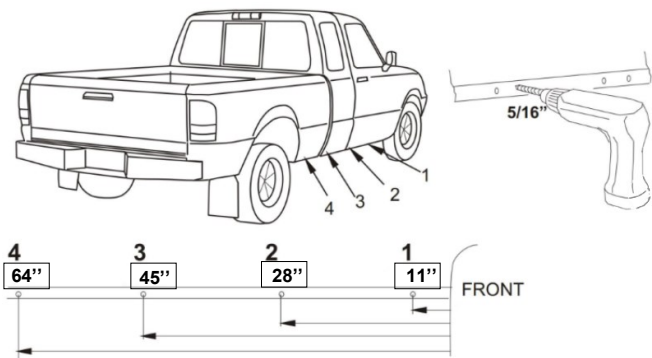

(Fig 1) Passenger Side Mounting Locations

STEP 2

Start from the passenger side front mounting location. Select (1) Passenger Front Mounting Bracket (DFM/PFM). Attach the Passenger Front Mounting Bracket with (2) ST6.3x25mm Hex Flange Self Tapping Screws, (1) M8X1.25-20mm Hex Bolt, (2) M8 Flat Washers, and (1) M8X1.25 Nylon Lock Nut, (Fig 2). Do not fully tighten hardware at this time.

Note: (2) Driver/Passenger Front Mounting Brackets are universal.

- (1) M8X1.25-20mm Hex Bolt
- (2) M8 Flat Washers
- (1) M8X1.25 Nylon Lock Nut

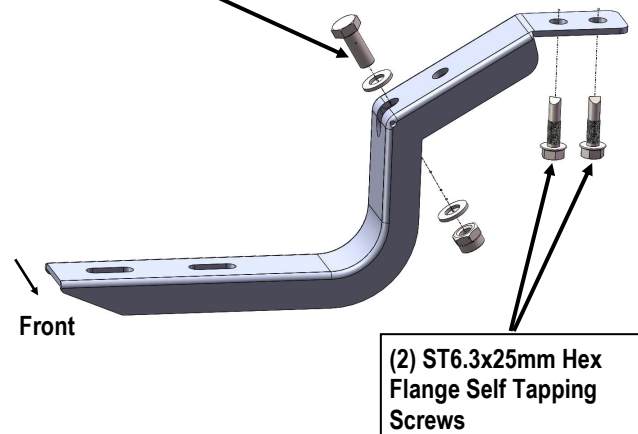

(Fig 2) Passenger Front Mounting Bracket Installation

STEP 3

Move to the passenger side 2nd, 3rd & 4th mounting locations. Select the Mounting Brackets. Repeat **Step 2** to install the Mounting Brackets, (Fig 3). Do not fully tighten hardware at this time.

Note: (6) Mounting Brackets are universal.

iBoard®

- (1) M8X1.25-20mm Hex Bolt
- (2) M8 Flat Washers
- (1) M8X1.25 Nylon Lock Nut

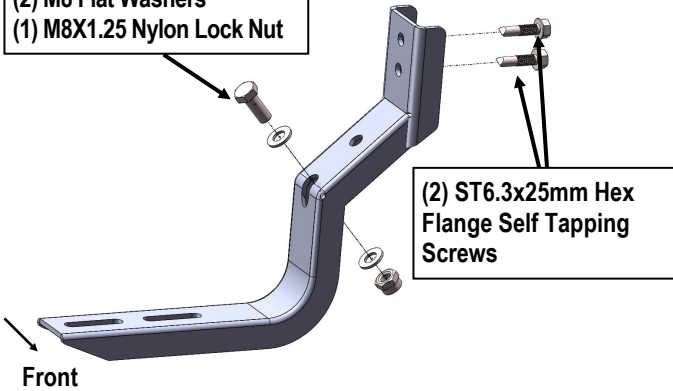

(Fig 3) Passenger Side 2nd & 3rd & 4th Mounting Bracket Installation

STEP 5

Select a Running Board. Slip (4) M6x1-20mm Square Head Bolts into each bottom channel (Fig 4). Carefully position the Running Board onto the (4) Mounting Brackets.

IMPORTANT: Do not slide the Running Board on the Brackets or the bottom surface of the board will be damaged. Attach the Running Board to each Mounting Bracket with (2) M6x1-20mm Square Head Bolts, (2) M6 Large Flat Washers and (2) M6 X1 Nylon Lock Nuts (Fig 5). Do not fully tighten at this time.

Level and adjust the Running Board and fully tighten all hardware.

M6X1-20mm Square Head Bolts

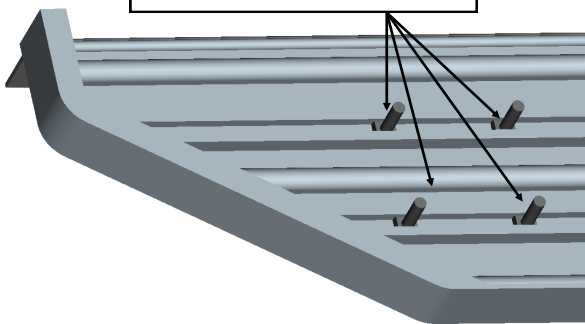

(Fig 4) Slip (3) M6X1-20mm Square Head Bolts Into Each Bottom Channel

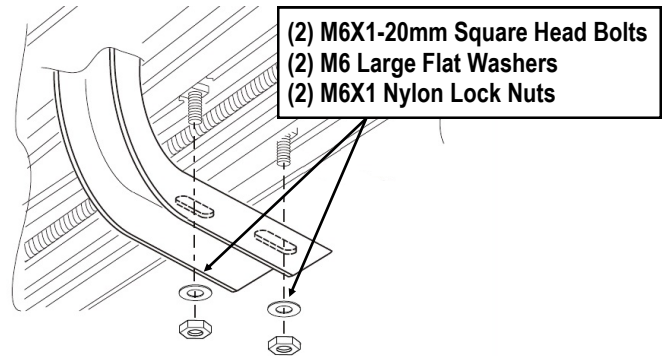

(Fig 5) Running Board Installed Onto Mounting Bracket

STEP 6

Repeat **Steps 1-5** for the other side Running Board installation. The installation is completed (Fig 6).



(Fig 6) Installation Completed

Attention

Do periodic inspections to the installation to make sure that all hardware is secure and tight.

In order to protect your bars/boards, please use only mild soap/non-abrasive products for cleaning.