

iBoard®



Scan for
Installation Video

iBoard® by APS

PART#: IB-R933/R934

READ INSTRUCTIONS CAREFULLY BEFORE STARTING INSTALLATION. REMOVE CONTENTS FROM BOX AND VERIFY ALL PARTS ARE PRESENT. ASSISTANCE IS RECOMMENDED.

*ROCKER PANEL MOUNT
*NO DRILLING REQUIRED

Fastener Size	Tightening Torque (ft-lbs)	Required
6mm	6-7	√
8mm	16-18	√
10mm	31-32	X
12mm	56-58	X
14mm	92-94	X

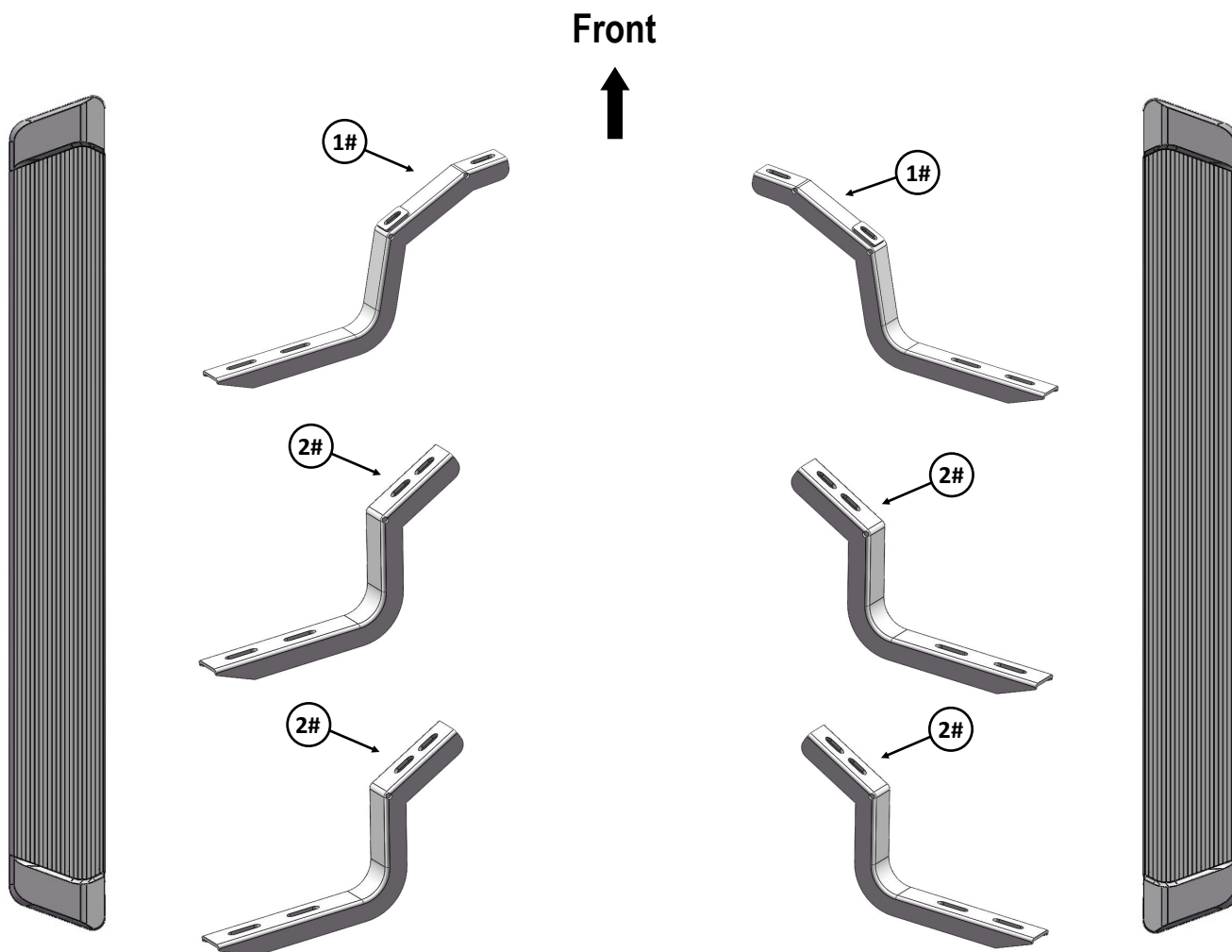

Customer Support: info@iboardauto.com



Scan for
Installation Video

Item	QTY	Description	Item	QTY	Description
1#	2	Driver/Passenger Front Mounting Brackets	3#	12	M8X1.25-20mm Hex Bolts
2#	4	Mounting Brackets			

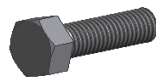

3 #

Hardware Package B (For Step Bar Installation)

Item	QTY	Description	Item	QTY	Description
1#	12	M6X1-20mm Square Head Bolts	3#	12	M6 Nylon Lock Nuts
2#	12	M6 Large Flat Washers			

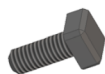

1#



2#



3#



STEP 1

Start installation at the driver side of the vehicle.

Locate the (3) factory mounting hole locations on the underside of vehicle rocker panel. Attach Driver Front Mounting Bracket to the first set of mount holes closest to the front of vehicle with (2) M8X1.25-20mm Hex Bolts. Don't fully tighten at this time, (Fig 1).

Note: The (2) Front Mounting Brackets are different with (4) Center and Rear Mounting Brackets.

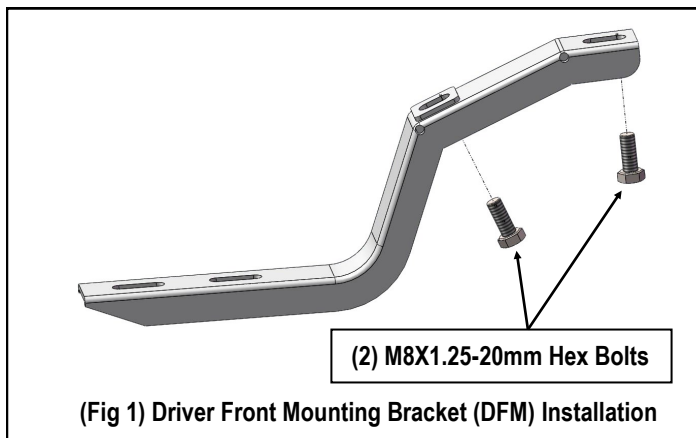

STEP 2

Move to the Center & Rear mounting locations. Repeat **Step 1** to install Center & Rear Mounting Brackets. Do not fully tighten at this time, (Fig 2).

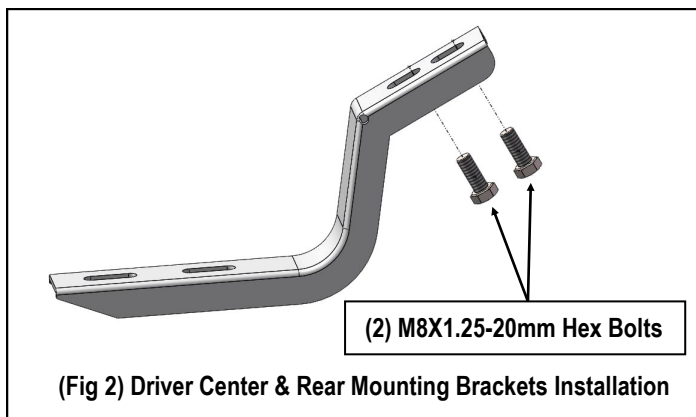

STEP 3

Once all (3) mounting brackets are installed. Select a Running Board. Slip (3) M6X1-20mm Square Head Bolts into each bottom channel (Fig 3). Carefully position the Running Board onto the (3) Mounting Brackets. Attach the Running Board to each Mounting Bracket with (2) M6X1-20mm Square Head Bolts, (2) M6 Large Flat Washers and (2) M6 Nylon Lock Nuts (Fig 4). Do not fully tighten at this time.

IMPORTANT: Do not slide the Running Board on the Brackets or the bottom surface of the board will be damaged.

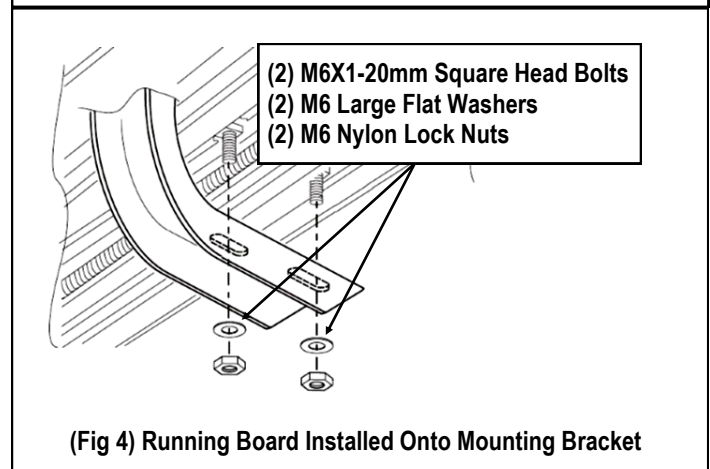
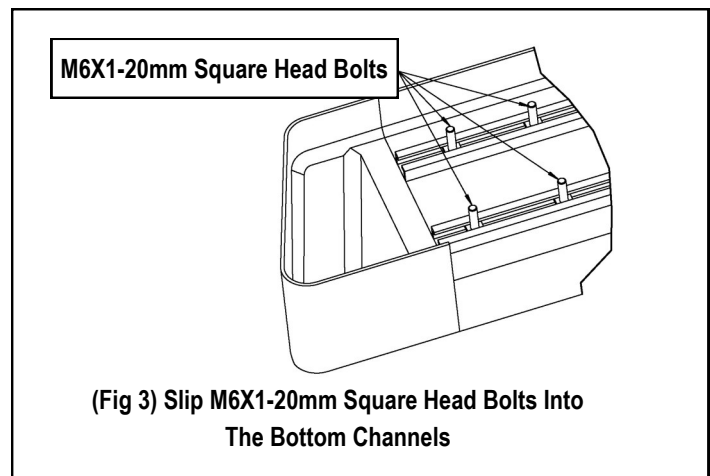



STEP 4

Level and adjust the Running Board and fully tighten all hardware.

Important: Please follow the recommended Tightening Torques shown in the table on page 1. Don't over tighten, or the nuts/bolts will be damaged.

STEP 5

Repeat **Steps 1-4** for the other side Running Board installation. The installation is completed.

Attention

Do periodic inspections to the installation to make sure that all hardware is secure and tight.

In order to protect your bars/boards, please use mild soap/non-abrasive products for cleaning only.