



PART#: IB-P971Y&H

iBoard® Series

READ INSTRUCTIONS CAREFULLY BEFORE STARTING INSTALLATION. REMOVE CONTENTS FROM BOX AND VERIFY ALL PARTS ARE PRESENT. ASSISTANCE IS RECOMMENDED.

*ROCKER PANEL MOUNT

*DRILLING IS REQUIRED / CUTTING IS REQUIRED

Fastener Size	Tightening Torque (ft-lbs)	Required
6mm	6-7	√
8mm	16-18	√
10mm	31-32	√
12mm	56-58	X
14mm	92-94	X

PART LIST

Driver Side Step Bar

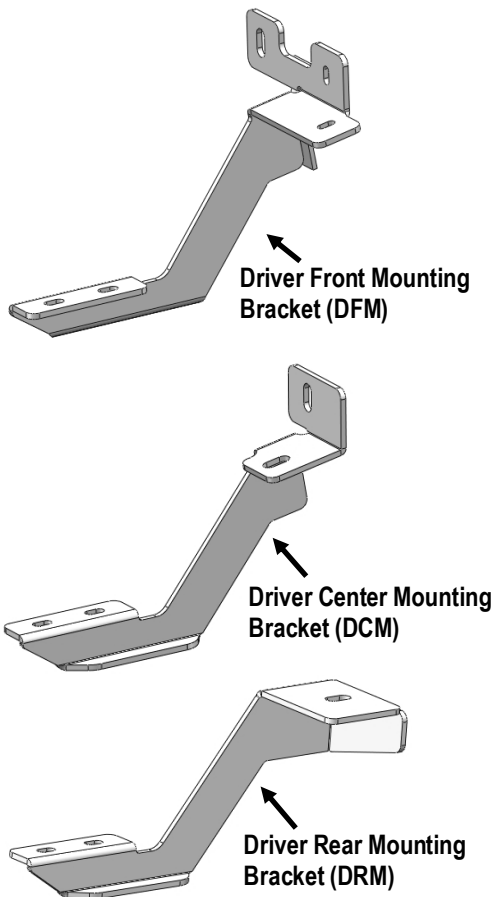

Front
↑

Passenger Side Step Bar

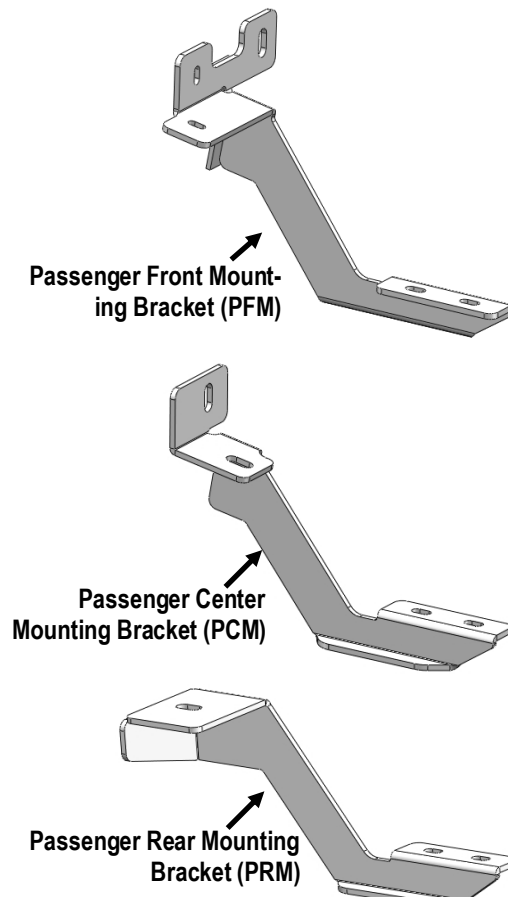
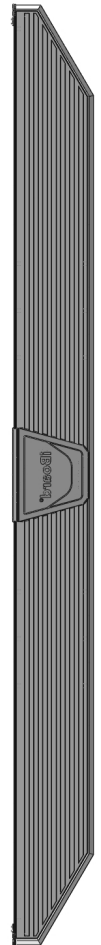



Scan for
Installation Video

Hardware Package A (For Bracket Installation)					
Item	QTY	Description	Item	QTY	Description
1#	1	Insert Installation Tool	8#	4	M10 Lock Washers
2#	2	M10X35 Bolt Plates	9#	4	M10 Hex Flange Nuts
3#	2	M10X50 T Block Bolts	10#	4	M10 Rivet Nuts
4#	4	M10 Plastic Washers	11#	4	M6X1-25mm Hex Bolts
5#	4	M10X1.5-25mm Hex Bolts	12#	4	M6 Flat Washers
6#	2	M10 Large Flat Washers	13#	4	M6 Lock Washers
7#	6	M10 Flat Washers	14#	3	M6 Rivet Nuts

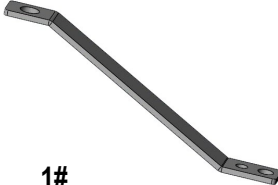

1#

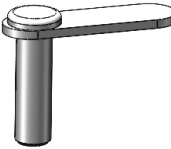

2#



3#

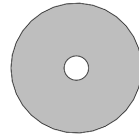

4#

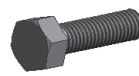

5#



6#



7#



8#



9#



10#

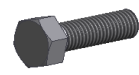

11#



12#



13#



14#

Hardware Package B (For Step Bar Installation)					
Item	QTY	Description	Item	QTY	Description
1#	12	M8X1.25-35mm Carriage Bolts	3#	12	M8 Nylon Lock Nuts
2#	12	M8 Large Flat Washers	4#	6	Sliders (Packed with Mounting Brackets)

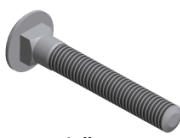

1 #



2 #

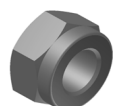

3 #

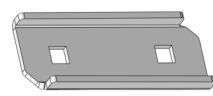

4 #



STEP 1

Starting installation under the driver side of the vehicle. Remove the plastic covers, **(Fig 1)**. Locate the (2) factory holes in the inside wall of the floor panel, **(Fig 1)**.

Pay close attention to the type and location of all factory hardware for reinstallation.

NOTE: The mounting locations may be covered by rubber plugs, sealant and/or undercoating.

IMPORTANT: Scrape any excess sealant from body panel before installing any and all Brackets.

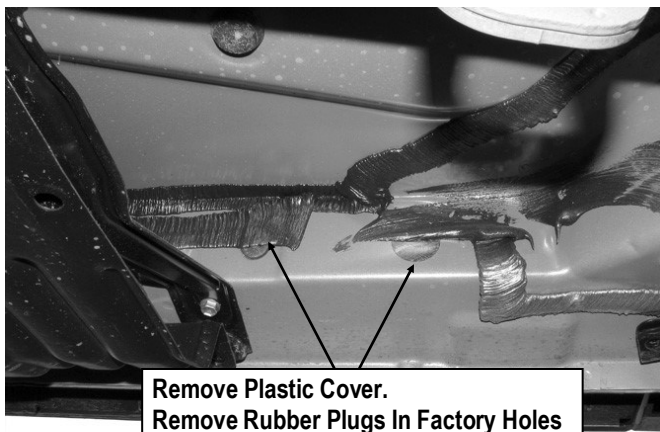

(Fig 1) Driver Side Front Mounting Location

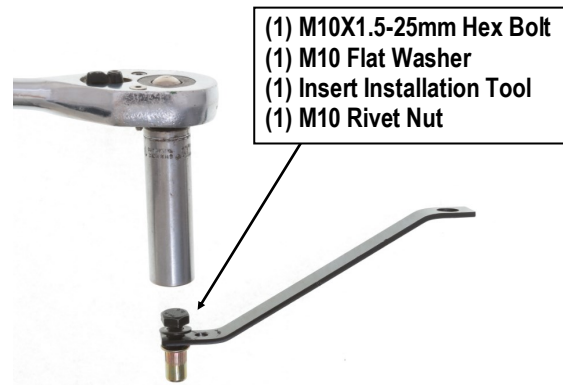

(Fig 2) Insert Installation Tool Assembly Pictured

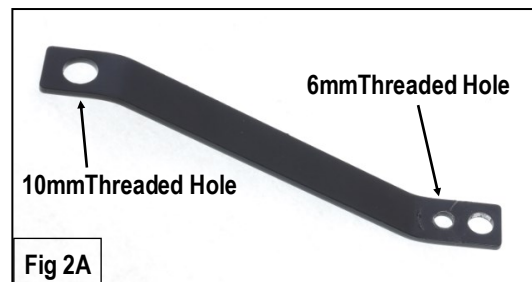
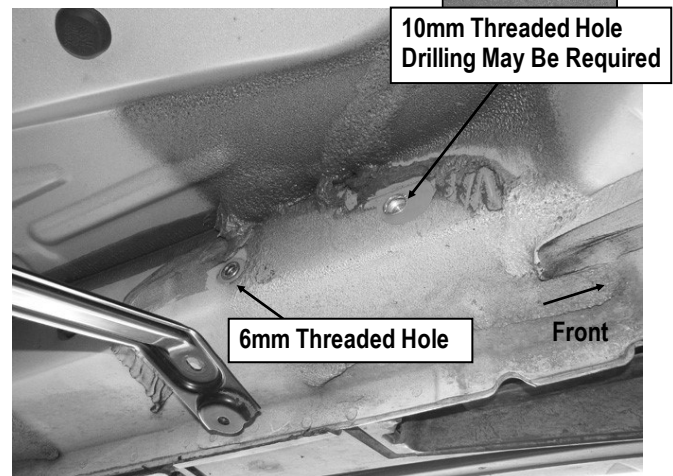
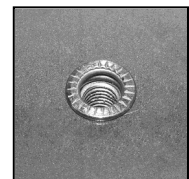

Fig 2A



(Fig 3) Driver Side Front Mounting Location

STEP 2

Select (1) M10 Rivet Nut, (1) Insert Installation Tool, (1) M10X1.5-25mm Hex Bolt and (1) M10 Flat Washer. Assemble the M10 Rivet Nut as pictured in **Fig 2**. **NOTE:** Select 10 mm hole in Insert Installation Tool, **(Fig 2A)**. Insert the Rivet Nut assembly into the forward, larger hole in the inner body panel, **(Fig 3)**.

NOTE: If Insert fits too tight, enlarge hole by drilling with a 1/2" drill bit. **IMPORTANT:** Be careful not to enlarge hole too much. Insert should fit snug in hole and lip on Insert should be against sheet metal surface.



STEP 3

Hold the assembly in place by the handle on the Tool and apply pressure to keep the Insert in the hole. Tighten the Hex Bolt on the assembly until Insert is fully compressed/expanded and locked in place, **(Fig 3)**.

NOTE: Do not over tighten or Insert failure or pull out may occur. Once the Threaded Insert is fully compressed, remove the Hex Bolt and Tool. Repeat **Steps 2 & 3** for all M10 Rivet Nut installations.

STEP 4

Next, assemble (1) M6 Rivet Nut and Insert Installation Tool as previously described. Insert the M6 Rivet Nut assembly into the small hole 4" back from the first Insert installation in **Steps 2 & 3**. **NOTE:** Select 6 mm hole in Insert Installation Tool, **(Fig 2A)**.

a. Driver Front Mounting Bracket installation:

Remove the 6mm factory hex bolt holding the bracket for the plastic cover up to the bottom of the frame channel, **(Fig 3)**. Select the Driver Front Mounting Bracket (**DFM**). Slide the mounting tab on the Bracket under the factory bracket. Bolt the Mounting Bracket to the M10 Rivet Nut with (1) M10X1.5-25mm Hex Bolt, (1) M10 Lock Washer, (1) M10 Flat Washer. Attach the Bracket to the M6 Rivet Nut with (1) M6X1-25mm Hex Bolt, (1) M6 Lock Washer and (1) M6 Flat Washer. Replace the factory 6mm bolt with (1) M6X1-25mm Hex Bolt, (1) M6 Lock Washer and (1) M6 Flat Washer, **(Fig 4)**. Do not fully tighten hardware at this time.

b. Passenger Front Mounting Bracket installation:

Repeat **Steps 1-4a** to install the Rivet Nut for the passenger side front Bracket but note that there is **no 6mm hex bolt** on the bottom of the body panel, **(Figs 5 & 6)**. Install the Passenger Front Mounting Bracket (**PFM**) as previously described in driver side installation, **(Fig 7)**. Mark the location of the bottom mounting tab onto the bottom of the floor panel. Drill a 3/8" hole in the marked location, **(Fig 6)**. Install (1) M6 Rivet Nut. Secure the bottom tab to the Threaded Insert with (1) M6X1-25mm Hex Bolt, (1) M6 Lock Washer and (1) M6 Flat Washer, **(Fig 8)**.

(2) M6X1.5-25mm Hex Bolts
(2) M6 Lock Washers
(2) M6 Flat Washers

(1) M10X1.5-25mm Hex Bolt
(1) M10 Lock Washer
(1) M10 Flat Washer

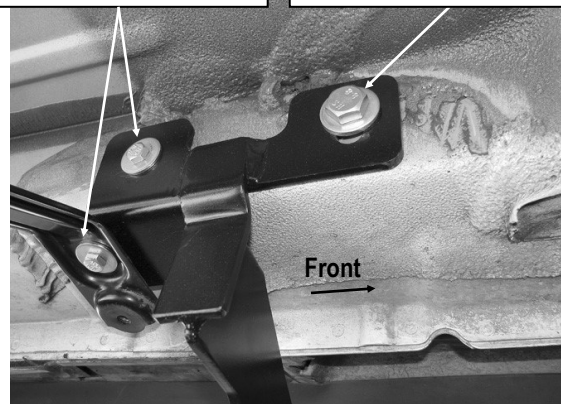

(Fig 4) Driver Side Front Mounting Bracket Installation

NOTE: To insert a 10mm Threaded Insert into the large factory hole, check for fit and/or use 1/2" drill bit as necessary

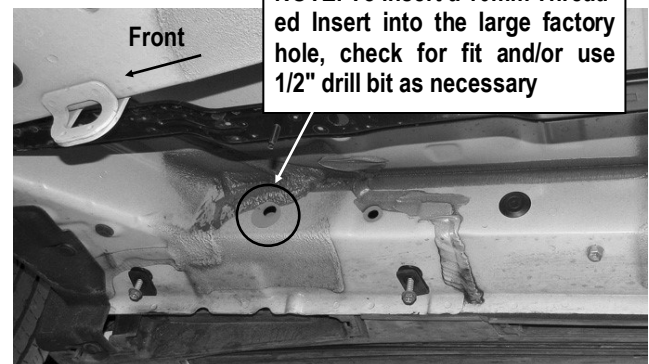

(Fig 5) Passenger Side Front Mounting Location

10mm Threaded Hole
Drilling May Be Required

6mm Threaded Hole

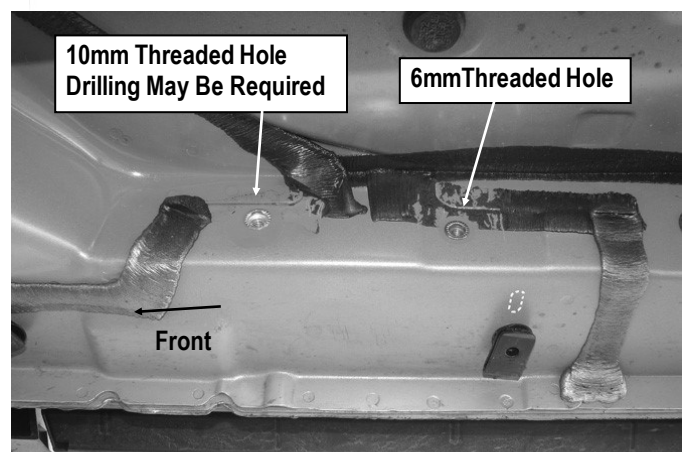

(Fig 6) Passenger Side Front Mounting Location

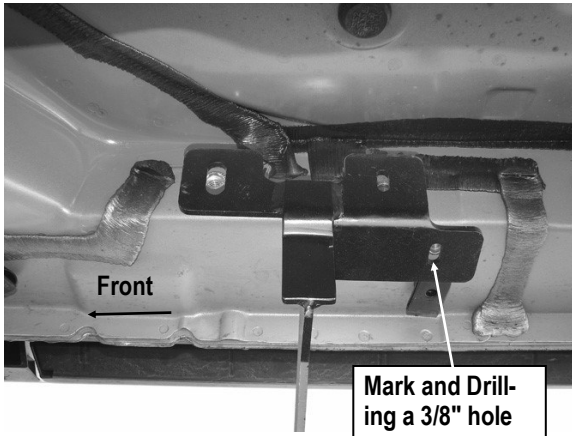

(Fig 7) Passenger Side Front Mounting Location

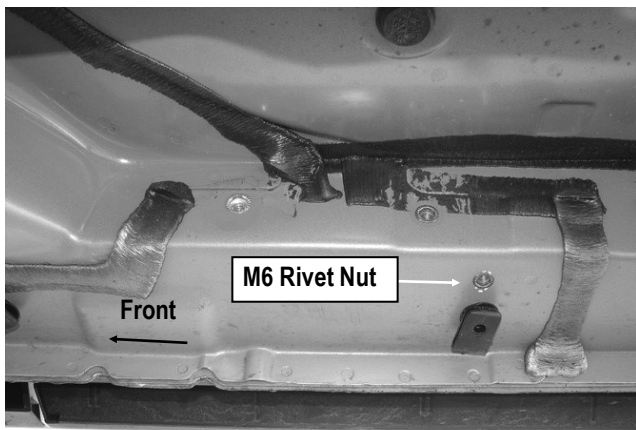

(Fig 8) Passenger Side Front Mounting Location

STEP 5

Move to the driver side center mounting location. Remove the plastic plug on the inside of the frame channel approximately 31-1/2" back along the floor panel from the front wheel opening, (Fig 9). Select (1) M10X35 Bolt Plate and (1) M10 Plastic Washer. Partially thread the M10 Plastic Washer onto the M10X35 Bolt Plate. Insert the Bolt Plate into the factory hole, (Fig 9). Thread the M10 Plastic Washer down tight against the sheet metal. **IMPORTANT:** The Plastic Washer is designed to prevent the Bolt Plate from falling into the body cavity and to aid Bracket installation.

a. Driver Center Mounting Bracket installation:

Remove the Plastic Washer on the bottom of the floor panel. Select (1) M10 Rivet Nut and assemble the insert tool, (Fig 9). Push the Rivet Nut into the hole in the bottom of the floor panel and install as previously described. **NOTE:** It may be necessary to enlarge hole slightly as described in Step 2.

Hold the Driver Center Mounting Bracket (DCM) up in place and attach it to the M10X35 Bolt Plate with (1) M10 Flat Washer and (1) M10 Hex Flange Nut . Secure the Bracket to the M10 Rivet Nut with (1) M10X1.5-25mm Hex Bolt, (1) M10 Lock Washer, (1) M10 Flat Washer, (Fig 10). Do not fully tighten hardware at this time.

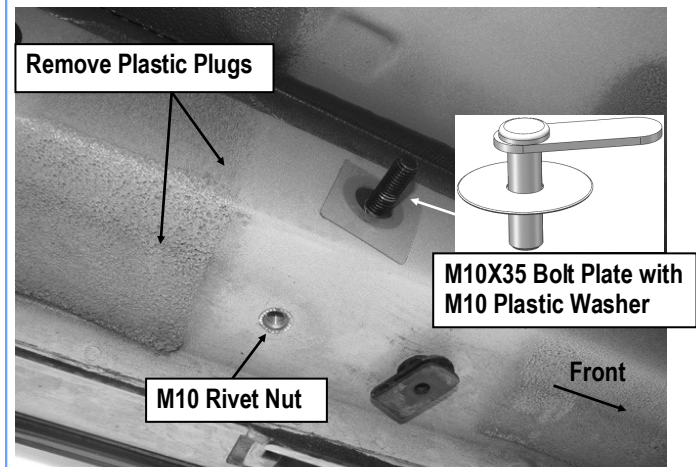

(Fig 9) Driver Side Center Mounting Location

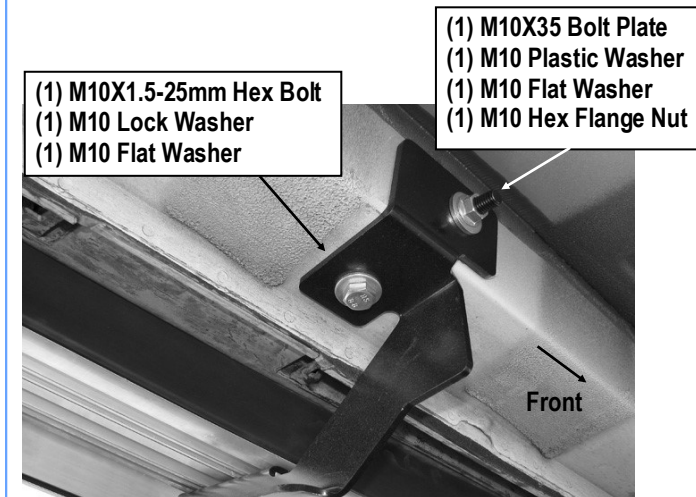

(Fig 10) Driver Side Center Mounting Location



b. Passenger Center Mounting Bracket installation:

Repeat **Step 5a** to install the Passenger Center Mounting Bracket (**PCM**) but note that there is no factory hole in the bottom of the frame channel, (similar to front Bracket install in **Step 4**). Bolt the Bracket to the M10X35 Bolt Plate as previously described with the Bracket tight against the bottom of the frame channel, (**Fig 11**). Mark the slot location onto the bottom of the channel, (**Fig 12**). Remove the Center Bracket. Drill a 1/2" hole in the marked location. Install the M10 Rivet Nut into the hole as previously described, (**Fig 13**). Reinstall the Bracket. Bolt the Bracket to the M10 Rivet Nut with (1) M10X1.5-25mm Hex Bolt, (1) M10 Lock Washer, (1) M10 Flat Washer. Do not fully tighten hardware at this time.

- (1) M10X35 Bolt Plate
- (1) M10 Plastic Washer
- (1) M10 Flat Washer
- (1) M10 Hex Flange Nut

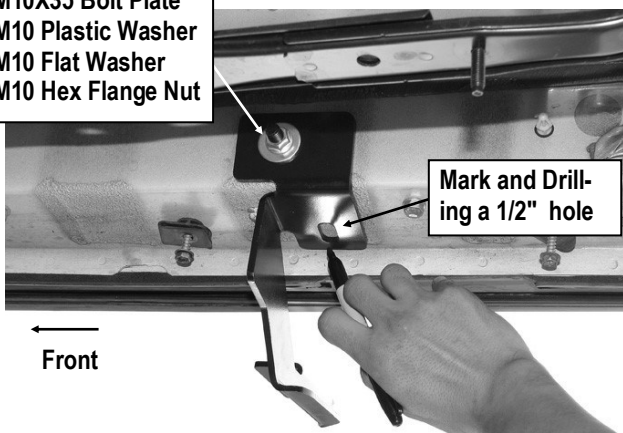

(Fig 11) Passenger Side Center Mounting Location

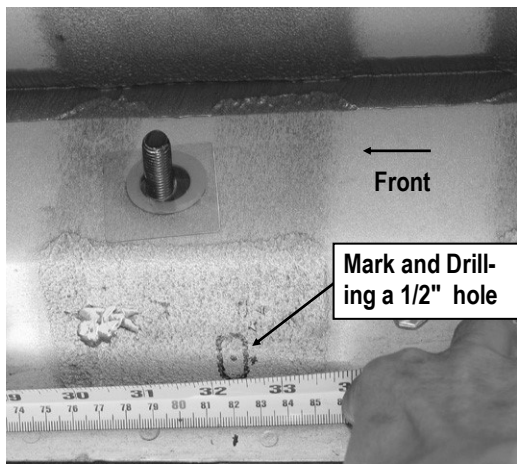

(Fig 12) Passenger Side Center Mounting Location

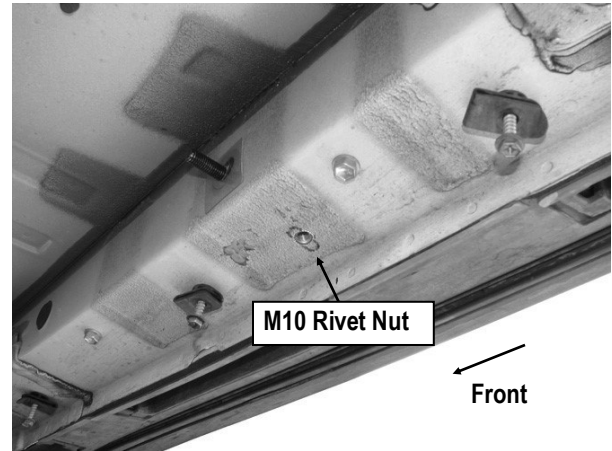

(Fig 13) Passenger Side Center Mounting Location

STEP 6

Move to the driver side rear mounting location and locate the large oval hole in the floor panel, (**Fig 14**). Remove rubber plug.

Select (1) M10X50 T Block Bolt and (1) M10 Plastic Washer. Partially thread the Plastic Washer onto the M10X50 T Block Bolt. Insert the T Block Bolt into the oval hole in the floor panel and rotate Bolt 90-degrees so that the Block is across the oval hole. Thread the Plastic Washer down until it is tight against the floor panel, (**Fig 15**).

Select the Driver Rear Mounting Bracket (**DRM**). Secure the Bracket to the M10X50 T Block Bolt with (1) M10 Large Flat Washer and (1) M10 Hex Flange Nut, (**Fig 16**). Do not fully tighten hardware at this time.



(Fig 14) Driver Side Rear Mounting Location



STEP 7

Once all (3) Driver side mounting brackets are installed, then proceed to the Step Bar installation. (**Figs 17 & 18**)

- (1) Select (1) Slider and (2) M8X1.25-35mm Carriage Bolts;
- (2) Install (2) M8X1.25-35mm Carriage Bolts in (1) Slider.
- (3) Slide the Slider (with carriage bolts) to the **Step Bar**.
- (4) Repeat to install the other (2) sliders to the step bar.
- (5) Attach the Step Bar (with the Sliders) onto the installed mounting brackets. Position the Sliders to the installed brackets. Secure the Step Bar to the installed Brackets by using (6) M8 Large Flat Washers and (6) M8 Nylon Lock Nuts and (3) Sliders, (**Fig 18**). Do not fully tighten hardware at this time.

Note: The Sliders are packed with the Mounting Brackets. Level and adjust the Step Bar and fully tighten all hardware.

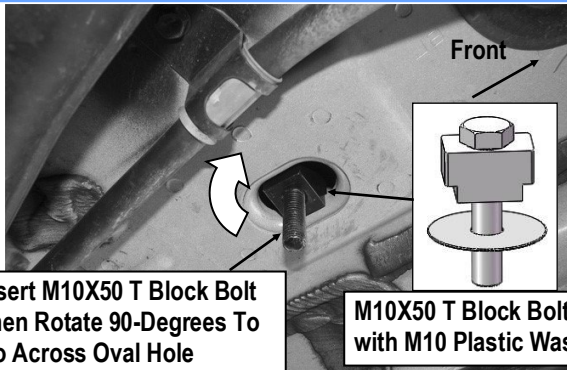

Insert M10X50 T Block Bolt
Then Rotate 90-Degrees To
Go Across Oval Hole

M10X50 T Block Bolt
with M10 Plastic Washer

(Fig 15) Driver Side Rear Mounting Location

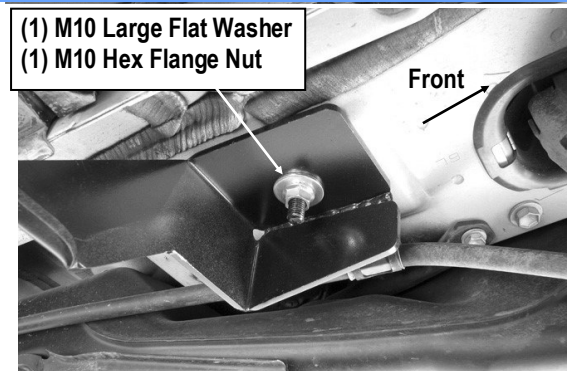

(1) M10 Large Flat Washer
(1) M10 Hex Flange Nut

(Fig 16) Driver Side Rear Mounting Location

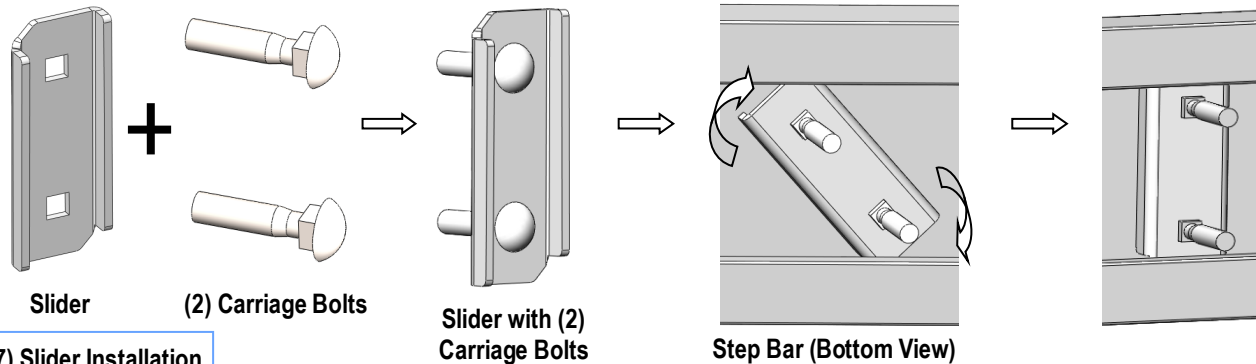

(Fig 17) Slider Installation

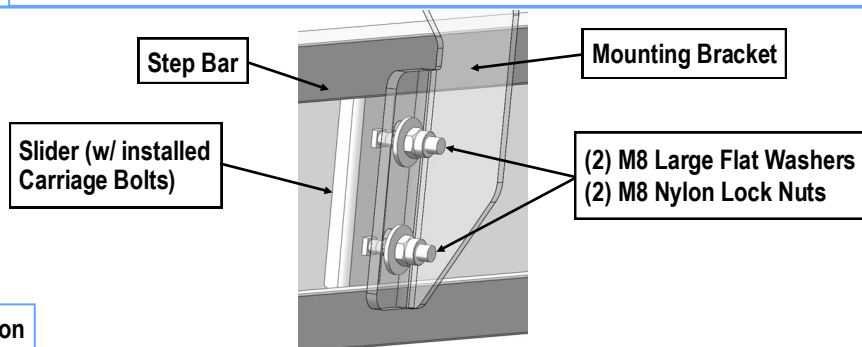

(Fig 18) Step Bar Installation



STEP 8

Level and adjust the Step Bar and fully tighten all hardware.

Once all hardware has been tightened, hold the plastic covers removed in **Step 1**, up in position, (**Fig 19A & 19B**). Trace the location of the Front and Center Mounting Brackets onto the covers, (**Fig 20A & 21A**). Carefully cut the plastic covers to clear the Brackets, (**Fig 20B & 21B**). **IMPORTANT:** Cut as little as possible from the covers. Reinstall the plastic covers with factory hardware. Fully tighten hardware at this time.

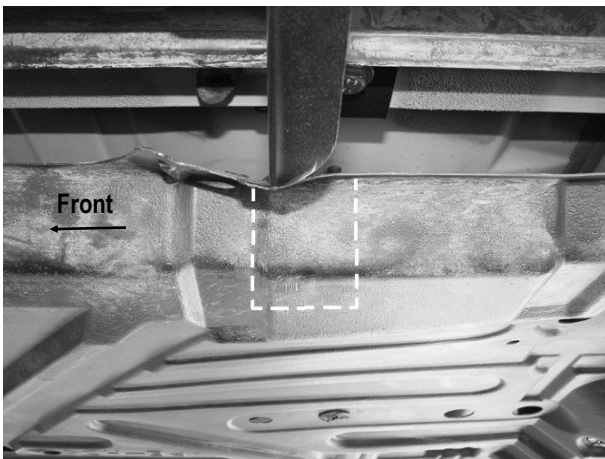

(Fig 19A) Hold Plastic Cover Up In Position To Determine Area To Cut From Cover. Driver Side Middle Cover Pictured



(Fig 19B) Hold Plastic Cover Up In Position To Determine Area To Cut From Cover. Driver Side Front Cover Pictured

Front
←

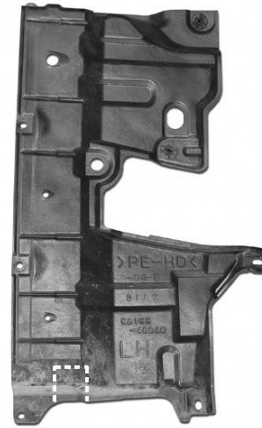

(Fig 20A) Driver Side Front Cover Pictured

Front
←

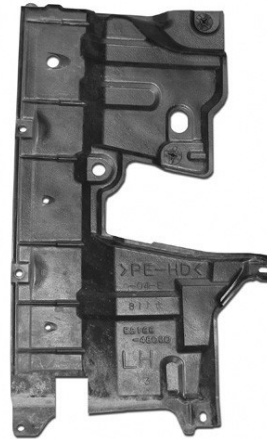

(Fig 20B) Cut Cover Only Enough To Clear Bracket. Cut Shown For Example Only

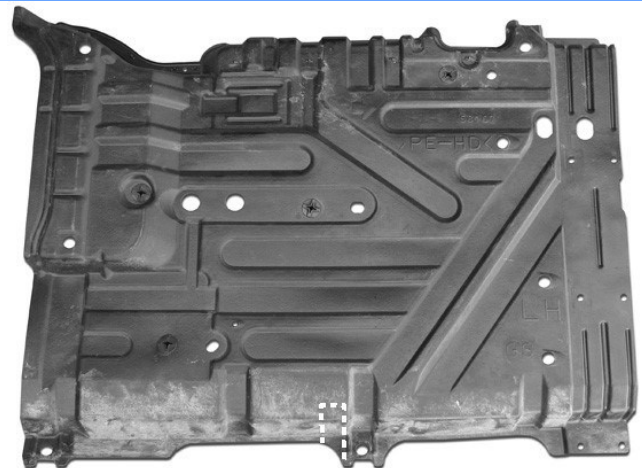

(Fig 21A) Driver Side Middle Cover

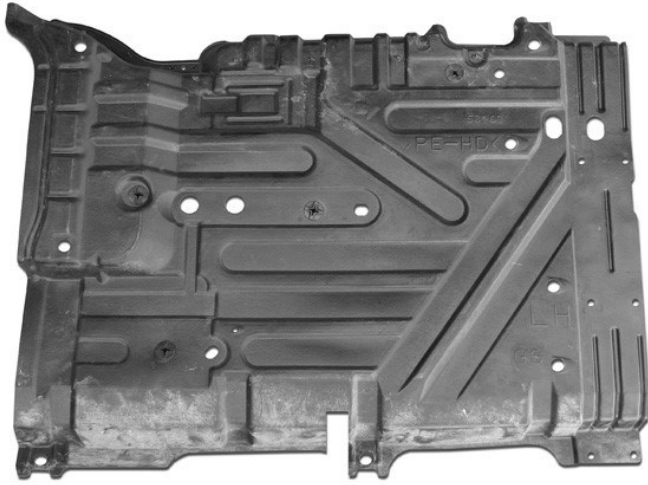

(Fig 21B) Cut Cover Only Enough To Clear Bracket. Cut Shown For Example Only

STEP 9

Repeat **Steps 1-8** for the other side Step Bar installation. **The installation is completed!!!**

Attention

Do periodic inspections to the installation to make sure that all hardware is secure and tight.

In order to protect your bars/boards, please use mild soap/non-abrasive products for cleaning only.