



## iBoard® by APS

PART#: IB-P936Y&H

READ INSTRUCTIONS CAREFULLY BEFORE STARTING INSTALLATION. REMOVE CONTENTS FROM BOX AND VERIFY ALL PARTS ARE PRESENT. ASSISTANCE IS RECOMMENDED.

\*ROCKER PANEL MOUNT  
\*NO DRILLING REQUIRED

| Fastener Size | Tightening Torque (ft-lbs) | Required |
|---------------|----------------------------|----------|
| 6mm           | 6-7                        | X        |
| 8mm           | 16-18                      | √        |
| 10mm          | 31-32                      | X        |
| 12mm          | 56-58                      | X        |
| 14mm          | 92-94                      | X        |

### PART LIST

Driver Side Step Bar

Front

Passenger Side Step Bar

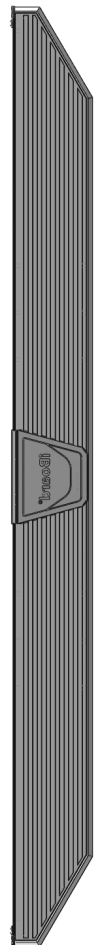
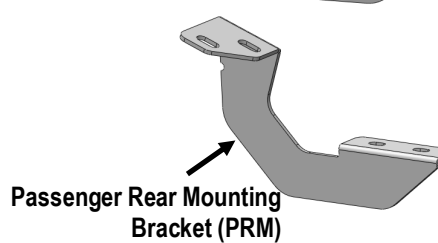
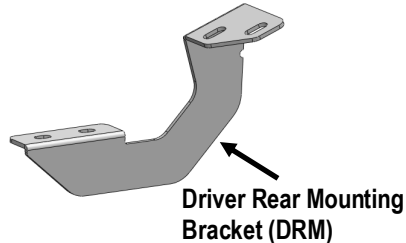
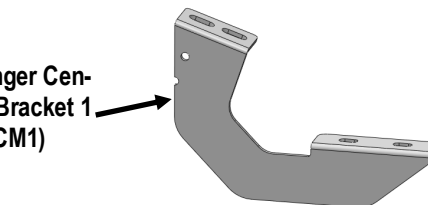
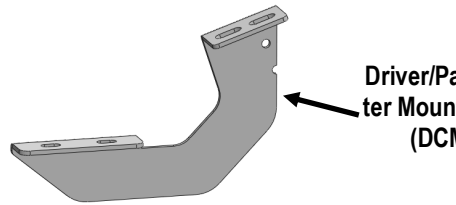
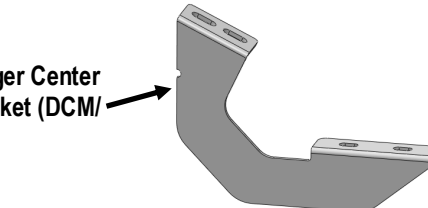
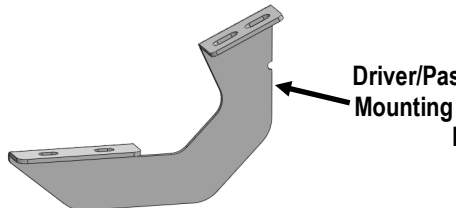
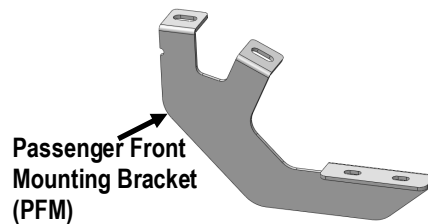
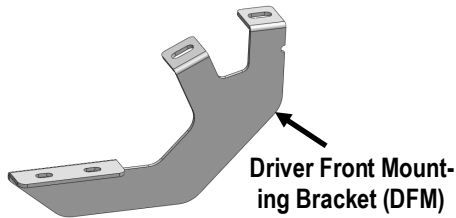



### Hardware Package A (For Bracket Installation)

| Item | QTY | Description            | Item | QTY | Description     |
|------|-----|------------------------|------|-----|-----------------|
| 1#   | 16  | M8X1.25-30mm Hex Bolts | 3#   | 16  | M8 Lock Washers |
| 2#   | 16  | M8 Large Flat Washers  |      |     |                 |

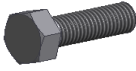

1#



2#



3#

### Hardware Package B (For Step Bar Installation)

| Item | QTY | Description                 | Item | QTY | Description                             |
|------|-----|-----------------------------|------|-----|---|
| 1#   | 16  | M8X1.25-35mm Carriage Bolts | 3#   | 16  | M8 Nylon Lock Nuts                      |
| 2#   | 16  | M8 Large Flat Washers       | 4#   | 8   | Sliders (Packed with Mounting Brackets) |

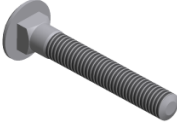

1 #



2 #



3 #

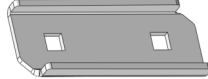

4 #



## STEP 1

Start installation from the driver side of the vehicle. Identify the Driver Side Mounting Locations along the inner side of the rocker panel, **(Fig 1)**. **Note:** (2) factory threaded holes on each location.

## STEP 2

Attach (4) Driver Side Mounting Brackets onto the mounting locations with (2) M8X1.25-30mm Hex Bolts, (2) M8 Lock Washers and (2) M8 Large Flat Washers for each mounting bracket, **(Fig 1)**. Do not fully tighten hardware at this time.

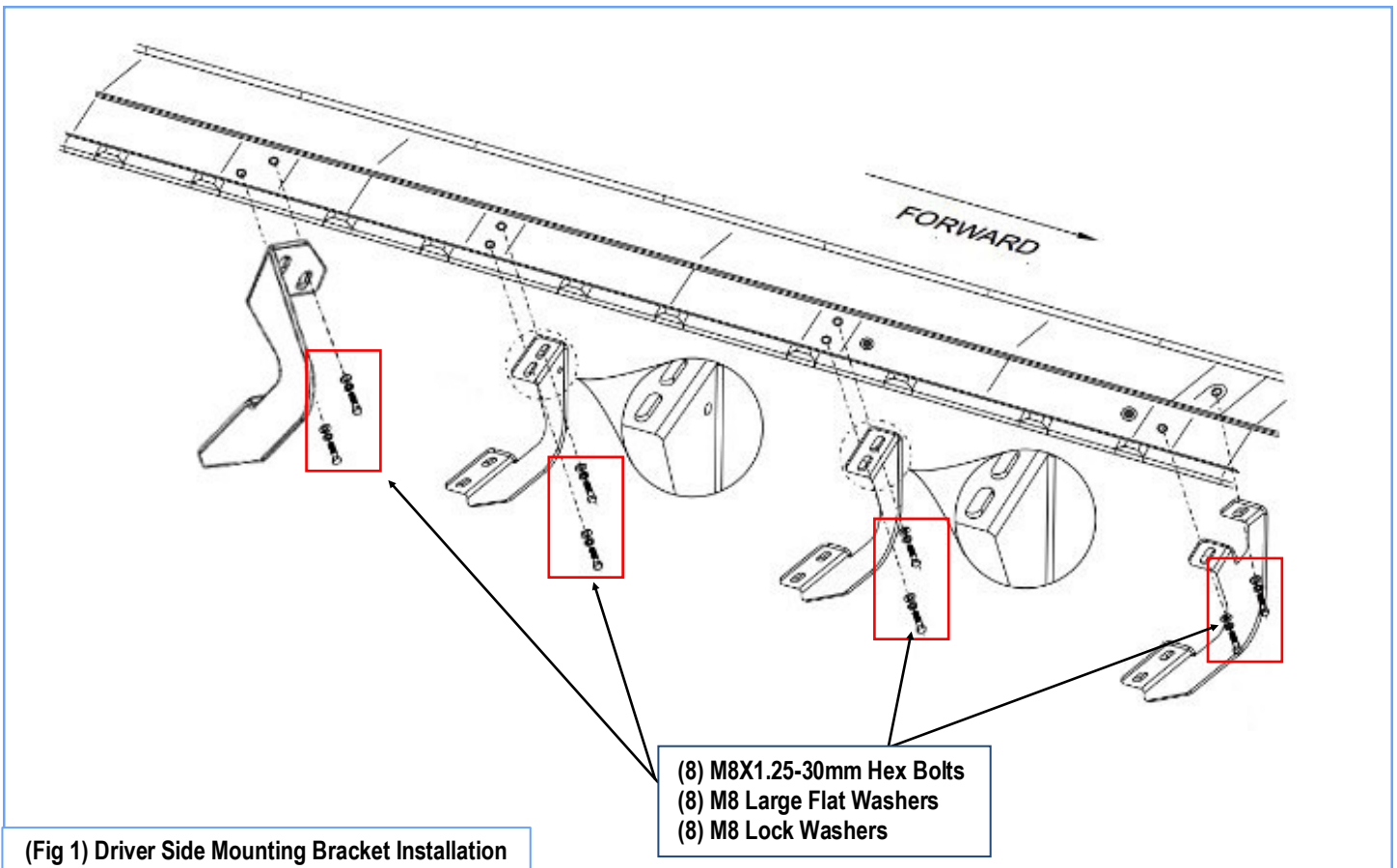



## STEP 3

Once all (4) Passenger side mounting brackets are installed, then proceed to the Step Bar installation. (**Figs 2 & 3**)

- (1) Select (1) Slider and (2) M8X1.25-35mm Carriage Bolts;
- (2) Install (2) M8X1.25-35mm Carriage Bolts in (1) Slider.
- (3) Slide the Slider (with carriage bolts) to the **Step Bar**.
- (4) Repeat to install the other (3) sliders to the step bar.
- (5) Attach the Step Bar (with the Sliders) onto the installed mounting brackets. Position the Sliders to the installed brackets. Secure the Step Bar to the installed Brackets by using (8) M8 Large Flat Washers and (8) M8 Nylon Lock Nuts and (4) Sliders, (**Fig 3**). Do not fully tighten hardware at this time.

**Note:** The Sliders are packed with the Mounting Brackets.

Level and adjust the Step Bar and fully tighten all hardware.

Repeat **Steps 1-3** for the other side Step Bar installation. **The installation is completed!!!**

### Attention

**Do periodic inspections to the installation to make sure that all hardware is secure and tight.**

**In order to protect your bars/boards, please use mild soap/non-abrasive products for cleaning only.**

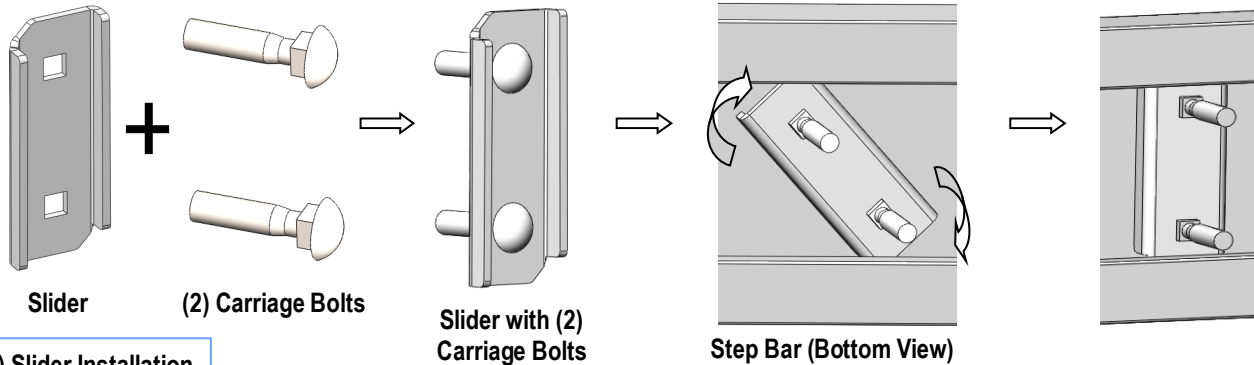

(Fig 2) Slider Installation

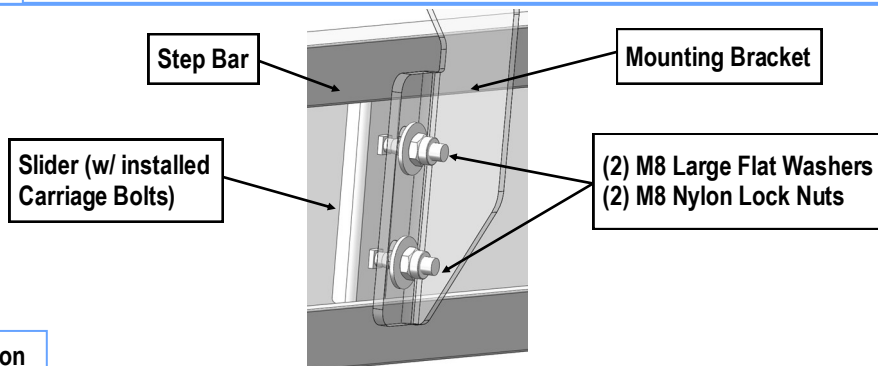

(Fig 3) Step Bar Installation