



iBoard® Series

PART#: IB-P935Y&H

READ INSTRUCTIONS CAREFULLY BEFORE STARTING INSTALLATION. REMOVE CONTENTS FROM BOX AND VERIFY ALL PARTS ARE PRESENT. ASSISTANCE IS RECOMMENDED.

*ROCKER PANEL MOUNT
*NO DRILLING REQUIRED

Fastener Size	Tightening Torque (ft-lbs)	Required
6mm	6-7	X
8mm	16-18	√
10mm	31-32	√
12mm	56-58	X
14mm	92-94	X

PART LIST

Driver Side Step Bar

Front
↑



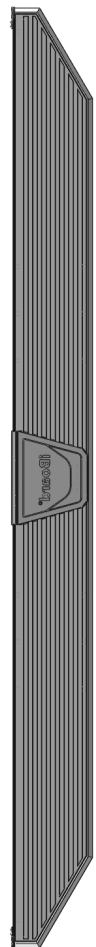
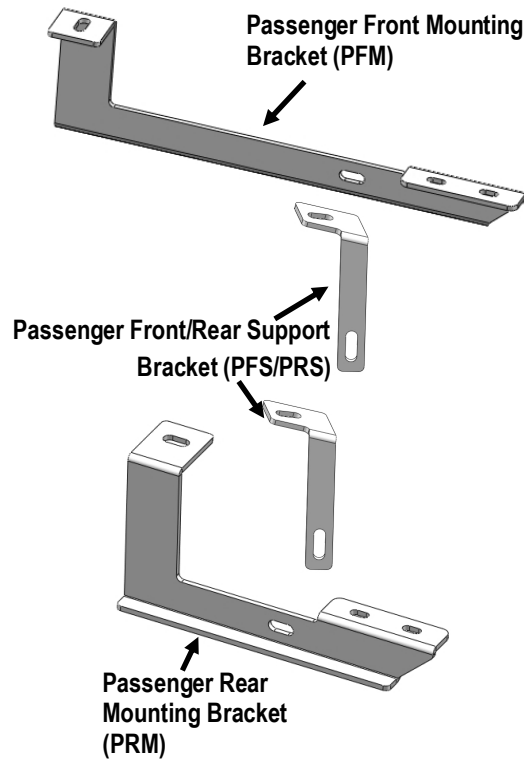
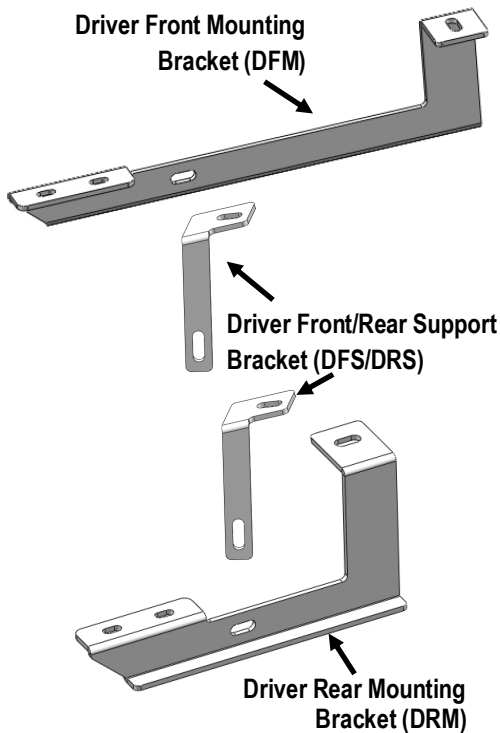



Passenger Side Step Bar



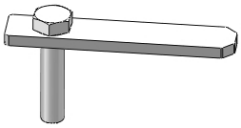

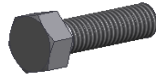
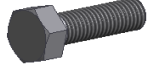

Scan for
Installation Video

Hardware Package A (For Bracket Installation)					
Item	QTY	Description	Item	QTY	Description
1#	2	M10X45 Bolt Plates	5#	2	M10 Large Flat Washers
2#	6	M10X1.5 Nut Plates	6#	14	M10 Flat Washers
3#	8	M10X1.5-30mm Hex Bolts	7#	12	M10 Lock Washers
4#	2	M10X1.5-20mm Hex Bolts	8#	10	M10 Hex Nuts

							
1#	2#	3#	4#	5#	6#	7#	8#

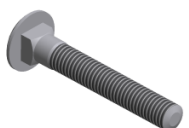
Hardware Package B (For Step Bar Installation)					
Item	QTY	Description	Item	QTY	Description
1#	8	M8X1.25-35mm Carriage Bolts	3#	8	M8 Nylon Lock Nuts
2#	8	M8 Large Flat Washers	4#	4	Sliders (Packed with Mounting Brackets)

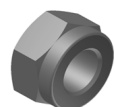
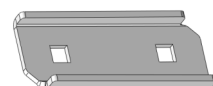
			
1 #	2 #	3 #	4 #



STEP 1

Start installation from the driver side rear of the vehicle. Remove rubber plugs if equipped, (**Fig 1**). Thread (1) M10X1.5-30mm Hex Bolt through (1) M10X1.5 Nut Plate. Insert assembled Bolt-Nut plate into the small outer hole, attach (1) Driver Rear Support Bracket (**DFS/DRS**) to Bolt-Nut plate using (1) M10 Flat Washer, (1) M10 Lock Washer, (1) M10X1.5 Hex Nut, (**Fig 2**). Do not fully tighten hardware at this time.

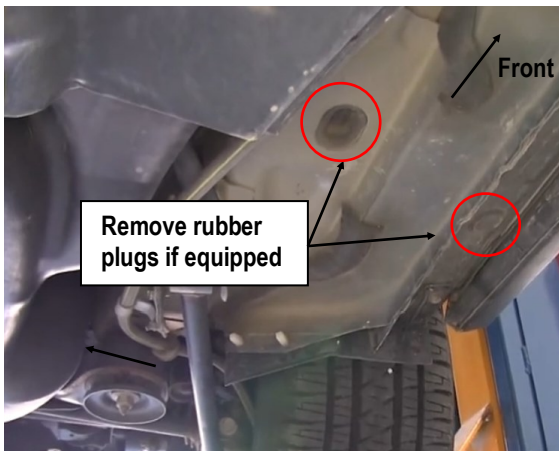

(Fig 1) Driver Rear Mounting Location

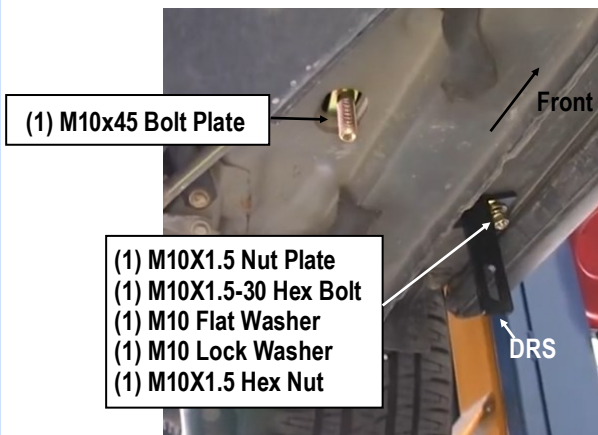

(Fig 2) Driver Rear Support Bracket Installed

STEP 2

Insert (1) M10X45 Bolt Plate into the larger oval hole as shown, (**Fig 2**). Install Driver Rear Mounting Bracket (**DRM**) to the vehicle using (1) M10 Flat Washer, (1) M10 Lock Washer, (1) M10X1.5 Hex Nut, (**Fig 3**). Connect Driver Front Support Bracket (**DFS/DRS**) to **DRM** with (1) M10X1.5-30mm Hex Bolt, (2) M10 Flat Washers, (1) M10 Lock Washer, (1) M10X1.5 Hex Nut, (**Fig 3**). Do not fully tighten hardware at this time.

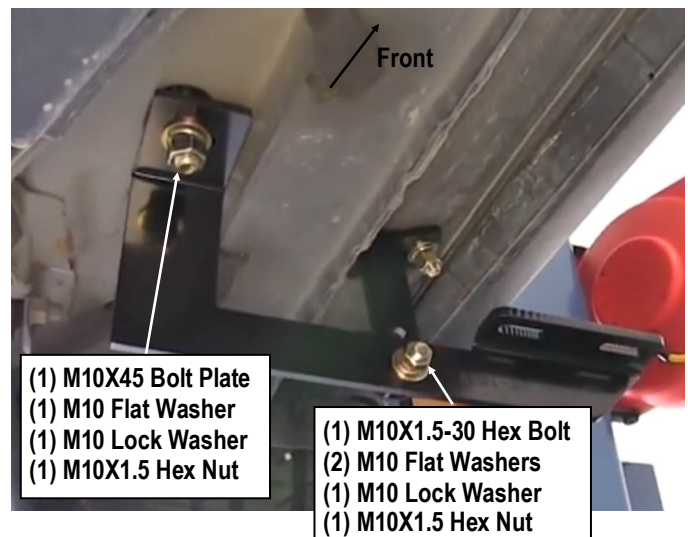

(Fig 3) Driver Rear Mounting Brackets Installed

STEP 3

Move to Driver Front Mounting Location, (**Fig 4**). Thread (1) M10X1.5-30mm Hex Bolt through (1) M10X1.5 Nut Plate. Insert assembled Bolt-Nut plate into the inner hole.

Install (1) Driver Front Support Bracket (**DFS/DRS**) with (1) M10X1.5-20mm Hex Bolt, (1) M10 Large Flat Washer, (1) M10 Lock Washer, and (1) M10X1.5 Nut Plate. Insert the assembled **DFS** into the outer hole, (**Fig 5**). Do not fully tighten hardware at this time.

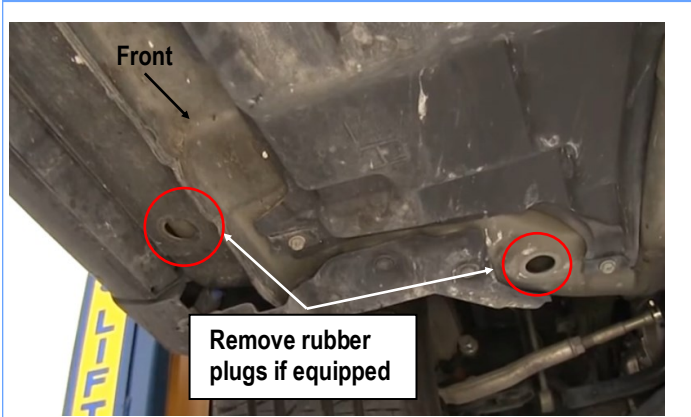

(Fig 4) Driver Front Mounting Location

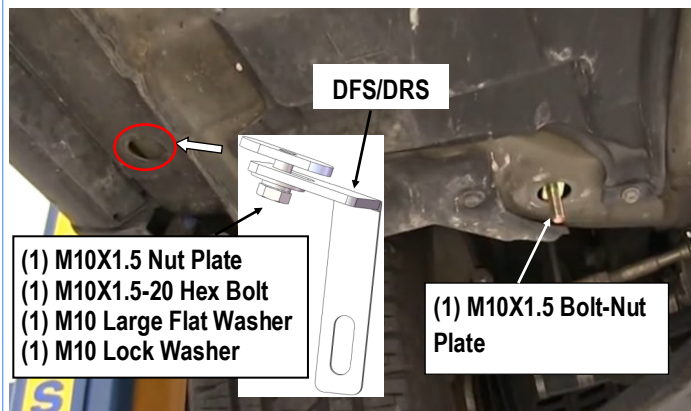

(Fig 5) Driver Front Support Bracket Installation

STEP 4

Install Driver Front Mounting Bracket (**DFM**) to the installed Nut-Bolt plate using (1) M10 Flat Washer, (1) M10 Lock Washer, (1) M10X1.5 Hex Nut, (**Fig 6**). Connect Driver Front Support Bracket (**DFS/DRS**) to **DRM** with (1) M10X1.5-30mm Hex Bolt, (2) M10 Flat Washers, (1) M10 Lock Washer, (1) M10X1.5 Hex Nut, (**Fig 6**). Do not fully tighten hardware at this time.

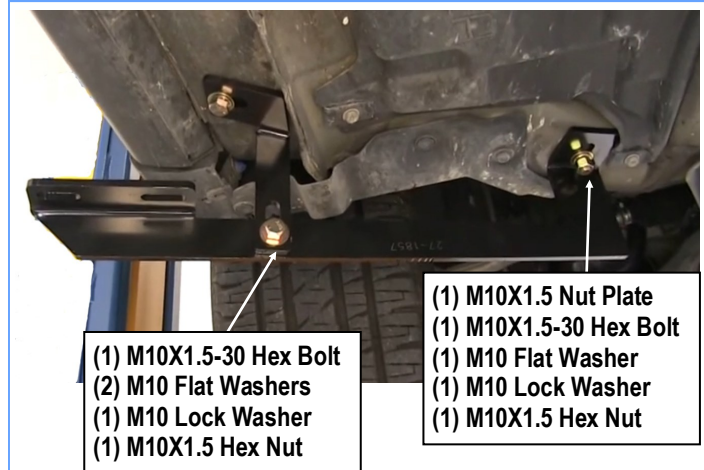

(Fig 6) Driver Side Front Mounting Brackets Installed

STEP 5

Once all (2) Driver side mounting brackets are installed, then proceed to the Step Bar installation. (**Figs 7 & 8**)

- (1) Select (1) Slider and (2) M8X1.25-35mm Carriage Bolts;
- (2) Install (2) M8X1.25-35mm Carriage Bolts in (1) Slider.
- (3) Slide the Slider (with carriage bolts) to the **Step Bar**.
- (4) Repeat to install the other (1) slider to the step bar.

(5) Attach the Step Bar (with the Sliders) onto the installed mounting brackets. Position the Sliders to the installed brackets. Secure the Step Bar to the installed Brackets by using (4) M8 Large Flat Washers and (4) M8 Nylon Lock Nuts and (2) Sliders, (**Fig 8**). Do not fully tighten hardware at this time.

Note: The Sliders are packed with the Mounting Brackets.

Level and adjust the Step Bar and fully tighten all hardware.

Repeat **Steps 1-5** for the other side Step Bar installation. **The installation is completed!!!**

Attention

Do periodic inspections to the installation to make sure that all hardware is secure and tight.
In order to protect your bars/boards, please use mild soap/non-abrasive products for cleaning only.

