

iBoard®



Scan for
Installation Video

iBoard® by APS

PART#: IB-R096

READ INSTRUCTIONS CAREFULLY BEFORE STARTING INSTALLATION. REMOVE CONTENTS FROM BOX AND VERIFY ALL PARTS ARE PRESENT. ASSISTANCE IS RECOMMENDED.

*ROCKER PANEL MOUNT
*NO DRILLING REQUIRED

Fastener Size	Tightening Torque (ft-lbs)	Required
6mm	6-7	√
8mm	16-18	√
10mm	31-32	X
12mm	56-58	X
14mm	92-94	X

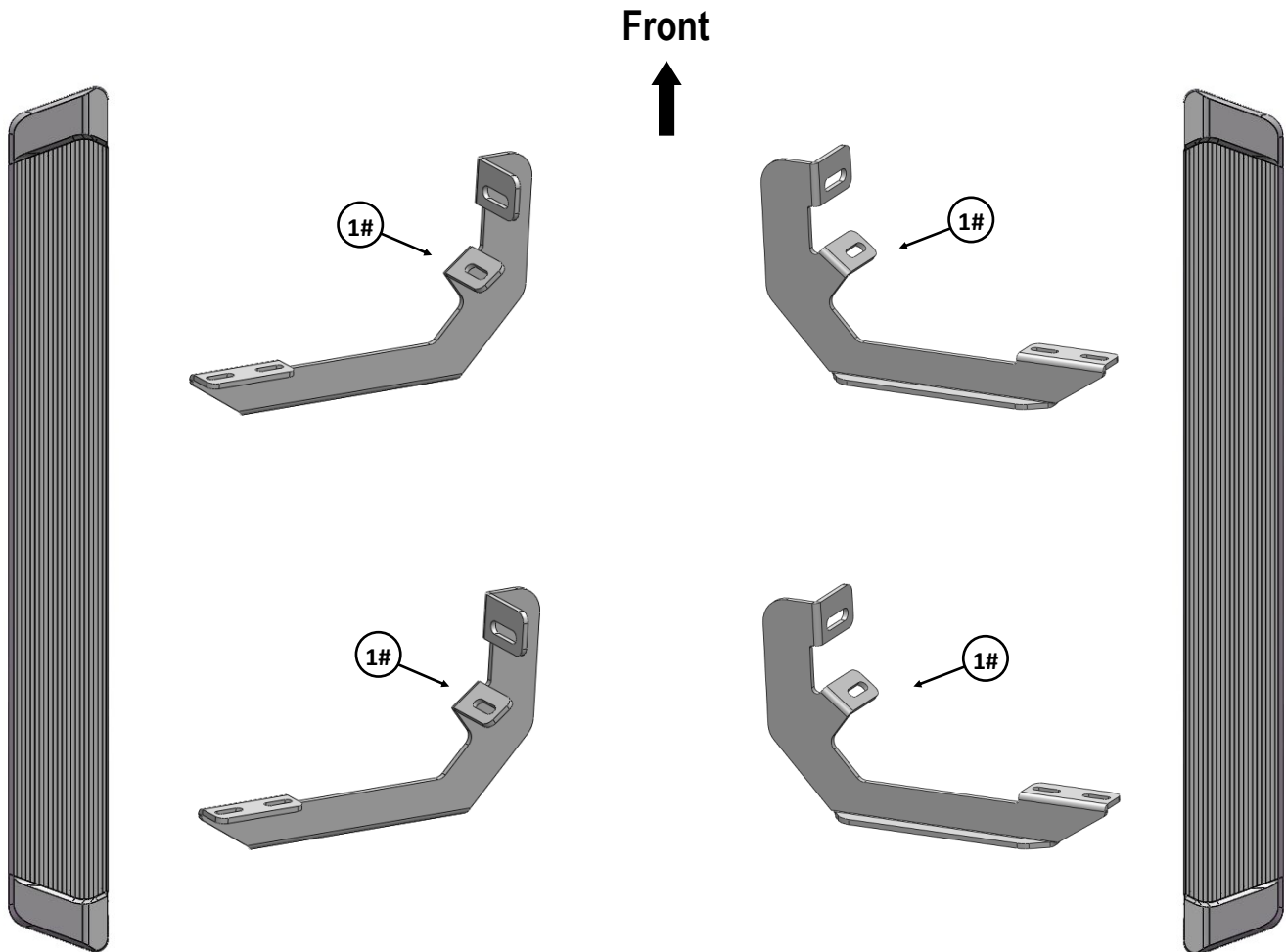

Driver Side Step Bar

Passenger Side Step Bar

Customer Support: info@iboardauto.com



Scan for
Installation Video

Hardware Package A (For Bracket Installation)

Item	QTY	Description	Item	QTY	Description
1#	4	Mounting Brackets	4#	4	M8 Lock Washers
2#	4	M8X1.25-35mm Hex Bolts	5#	4	M8 Hex Nuts
3#	8	M8 Large Flat Washers			

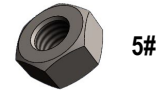

Hardware Package B (For Step Bar Installation)

Item	QTY	Description	Item	QTY	Description
1#	8	M6X1-20mm Square Head Bolts	3#	8	M6 Nylon Lock Nuts
2#	8	M6 Large Flat Washers			

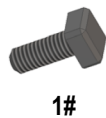



STEP 1

Start installation from the driver side front of the vehicle. Locate the factory threaded holes or stud located on the side of the inner body panel, (**Fig 1**). **NOTE:** Remove the plastic plug or any insulation on the side panel to locate the threaded holes.

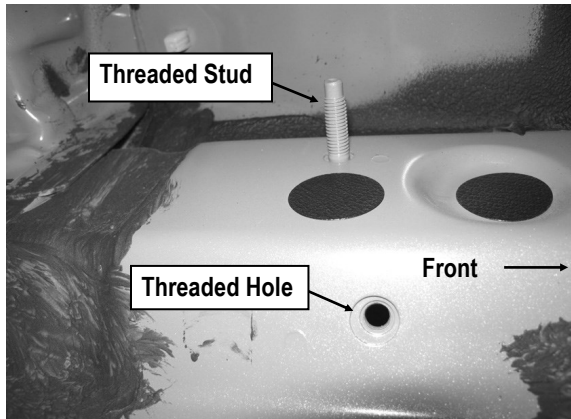

(Fig 1) Driver Side Front Mounting Bracket Location

STEP 2

Select (1) Mounting Bracket. Bolt the Mounting Bracket to the vehicle with (1) M8X1.25-35mm Hex Bolt, (2) M8 Large Flat Washers, (2) M8 Lock Washers and (1) M8 Hex Nut, (**Figs 2 & 3**). Do not fully tighten hardware at this time.

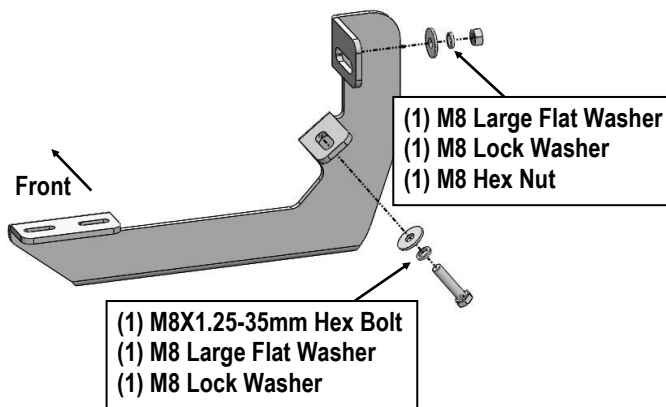

(Fig 2) Driver Side Front Mounting Bracket Installation

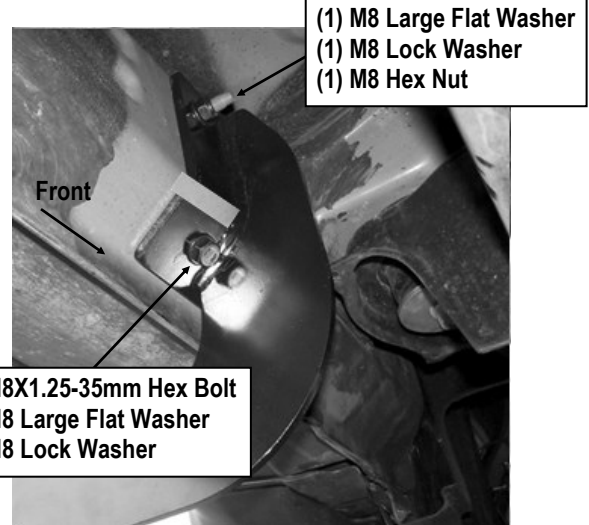

(Fig 3) Driver Side Front Mounting Bracket Installation

STEP 3

Move to the rear mounting location. Repeat **Steps 1 – 2** for Driver Side Rear Mounting Bracket installation. Do not fully tighten hardware at this time.

STEP 4

Once all (2) mounting brackets are installed. Select a Running Board. Slip (2) M6X1-20mm Square Head Bolts into each bottom channel (**Fig 4**). Carefully position the Running Board onto the (2) Mounting Brackets. Attach the Running Board to each Mounting Bracket with (2) M6X1-20mm Square Head Bolts, (2) M6 Large Flat Washers and (2) M6 Nylon Lock Nuts (**Fig 5**). Do not fully tighten at this time.

IMPORTANT: Do not slide the Running Board on the Brackets or the bottom surface of the board will be damaged.



M6X1-20mm Square Head Bolts

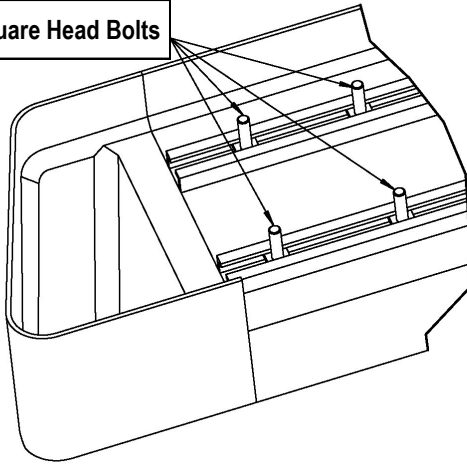

(Fig 4) Slip M6X1-20mm Square Head Bolts Into The Bottom Channels

(2) M6X1-20mm Square Head Bolts
(2) M6 Large Flat Washers
(2) M6 Nylon Lock Nuts

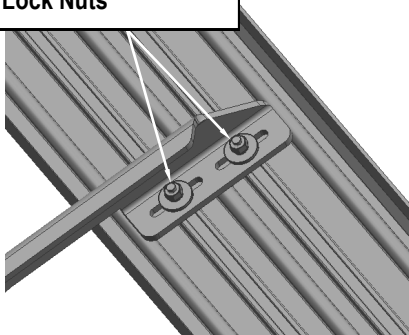

(Fig 5) Running Board Installed Onto Mounting Bracket

STEP 5

Level and adjust the Running Board and fully tighten all hardware.

Important: Please follow the recommended Tightening Torques shown in the table on page 1. Don't over tighten, or the nuts/bolts will be damaged.

STEP 6

Repeat **Steps 1-5** for the other side Running Board installation. The installation is completed .

Attention

Do periodic inspections to the installation to make sure that all hardware is secure and tight.

In order to protect your bars/boards, please use mild soap/non-abrasive products for cleaning only.