



iBoard® by APS

PART#: IB-R407

READ INSTRUCTIONS CAREFULLY BEFORE STARTING INSTALLATION. REMOVE CONTENTS FROM BOX AND VERIFY ALL PARTS ARE PRESENT. ASSISTANCE IS RECOMMENDED.

*ROCKER PANEL MOUNT
*DRILLING IS REQUIRED

Fastener Size	Tightening Torque (ft-lbs)	Required
6mm	6-7	√
8mm	16-18	√
10mm	31-32	√
12mm	56-58	X
14mm	92-94	X

PART LIST

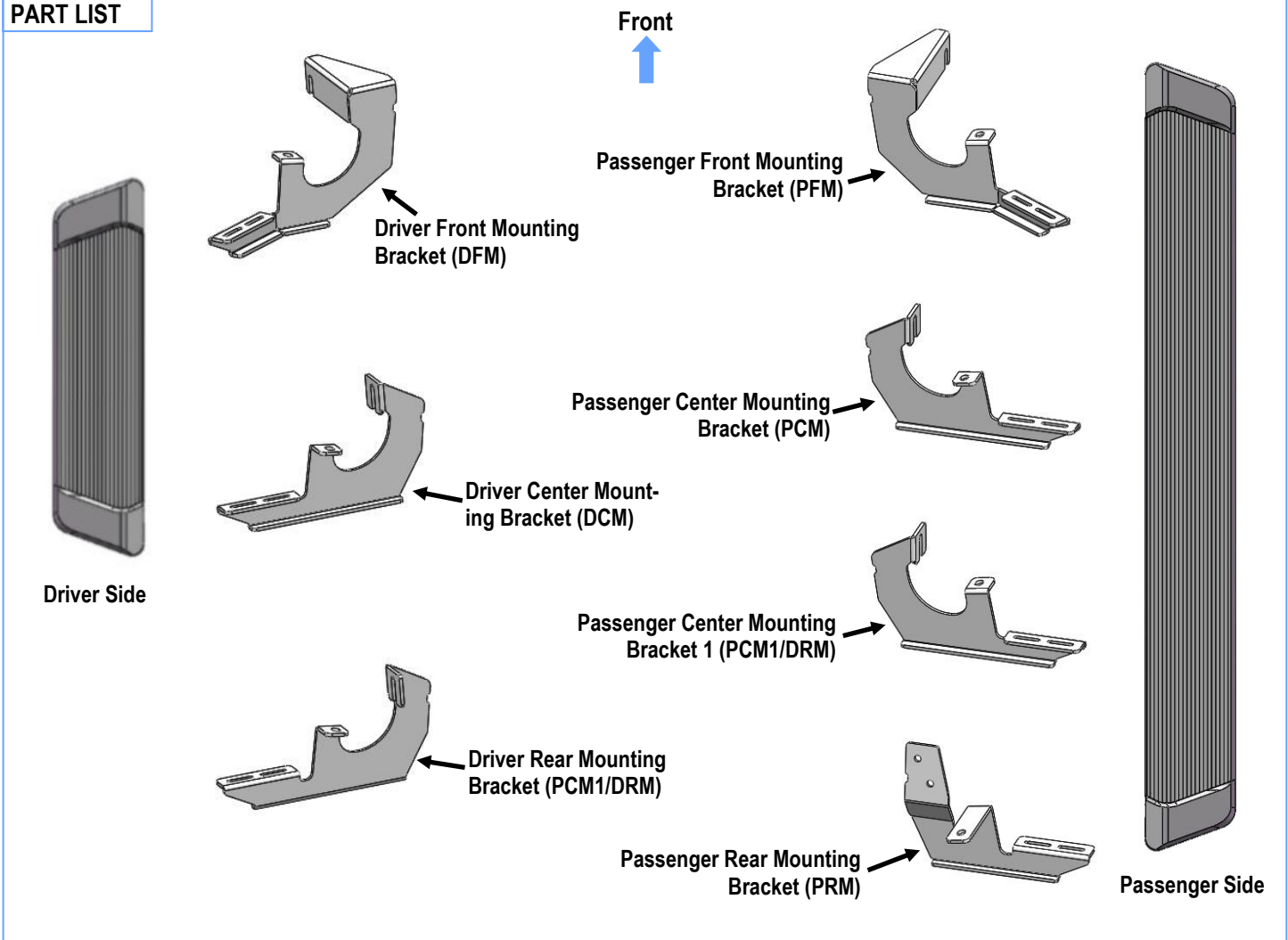



Hardware Package A (For Bracket Installation)

Item	QTY	Description	Item	QTY	Description
1#	13	M10 Bolt Plates	5#	2	M8X1.25-30mm Hex Bolts
2#	6	M10 Plastic Washers	6#	4	M8 Large Flat Washers
3#	13	M10 Flat Washers	7#	2	M8 Lock Washers
4#	13	M10 Nylon Lock Nuts	8#	2	M8 Hex Nuts



1#

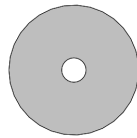

2#



3#



4#

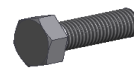

5#



6#



7#



8#

Hardware Package B (For Step Bar Installation)

Item	QTY	Description	Item	QTY	Description
1#	14	M6X1-20mm Square Head Bolts	3#	14	M6 Nylon Lock Nuts
2#	14	M6 Large Flat Washers			

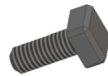

1#



2#



3#



STEP 1

Starting installation on the passenger side front of the vehicle. From the front wheel opening, locate the factory mounting holes along the bottom of the pinch weld and body panel, **(Fig 1 & 2)**.

NOTE: Some mounting holes will be covered by plugs or tapes, remove if equipped.

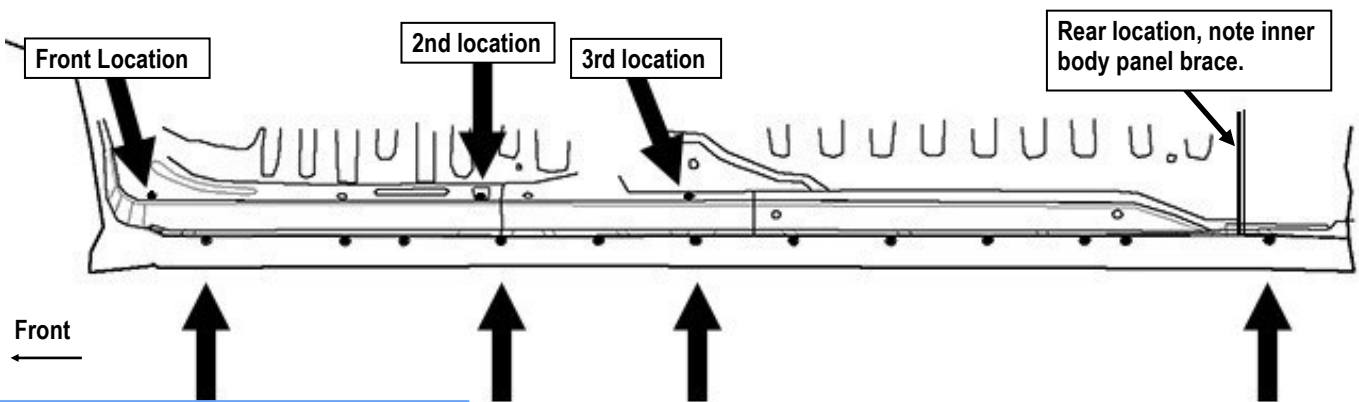

(Fig 1) Passenger Side Mounting Locations

STEP 2

Select (2) M10 Bolt Plates and (1) M10 Plastic Washer. Insert (2) M10 Bolt Plates into the Passenger Side Front Mounting holes and thread (1) M10 Plastic Washer onto the upper Bolt Plate to hold the bolt plate in place, **(Fig 3)**.

IMPORTANT: The Plastic Washer is designed to prevent the Bolt Plate from falling into the body panel and to aid in Bracket installation. The Plastic Washers are not required for the Bolt Plates installed along the bottom of the outer body panel (outside of the pinch weld).

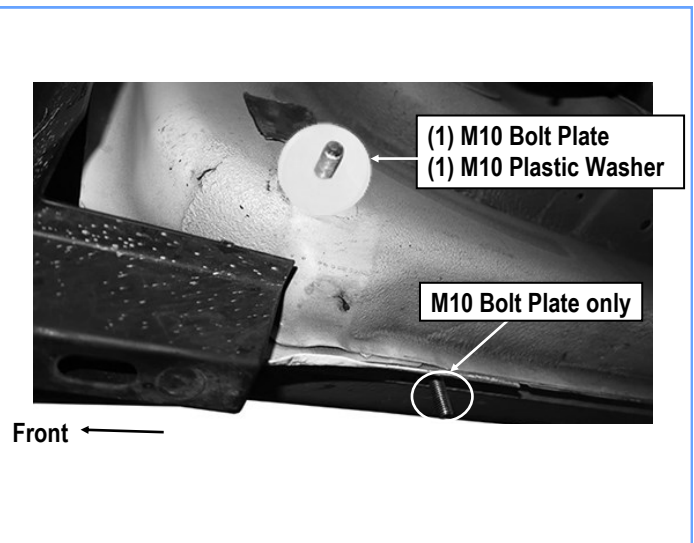

(Fig 2) Passenger Front Mounting Bracket Location



STEP 3

Select the Passenger Side Front Mounting Bracket. Attach the Passenger Front Mounting Bracket to the installed (2) M10 Bolt Plates with (1) M10 Plastic Washer, (2) M10 Flat Washers and (2) M10 Nylon Lock Nuts, (Figs 3 & 4). Do not fully tighten hardware at this time.

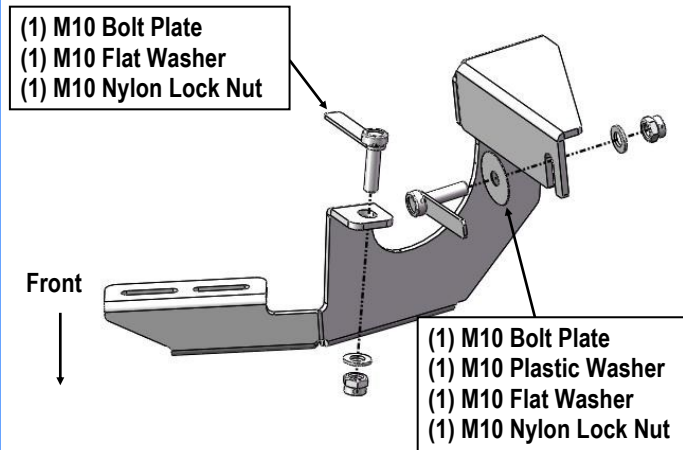

(Fig 3) Passenger Front Mounting Bracket Installed

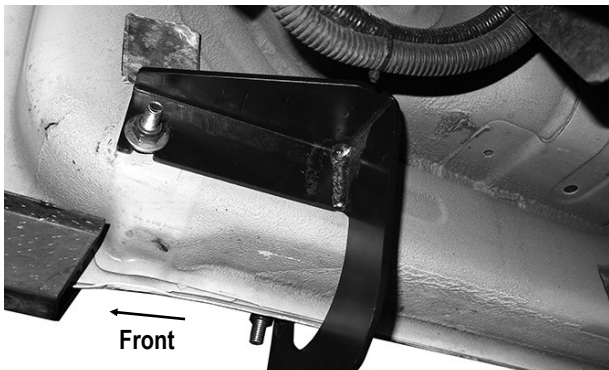

(Fig 4) Passenger Front Mounting Bracket Installed

STEP 4

Move to the Passenger Side Center Mounting Location, (Fig 5). Repeat **Steps 1-3** to install the Passenger Center Mounting Bracket (PCM), (Fig 6). Do not fully tighten hardware at this time.

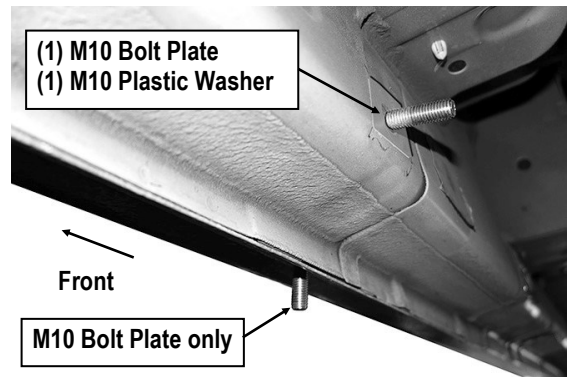

(Fig 5) Passenger Side 2nd Mounting Location

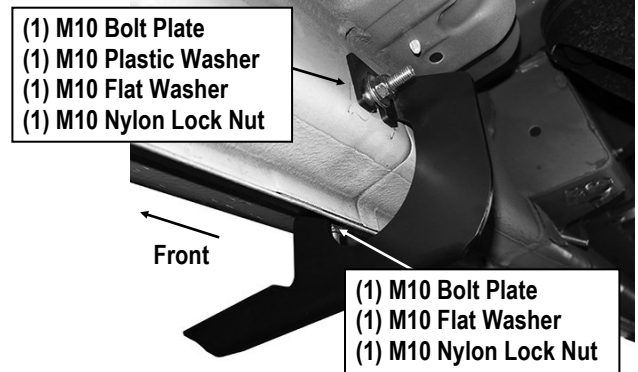

(Fig 6) Passenger Center Mounting Bracket Installed

STEP 5

Move to the 3rd mounting location beneath the front of the sliding door, (Fig 7). Repeat **Steps 1—3** to install the Passenger Center Mounting Bracket 1 (PCM1/DRM), (Fig 8).

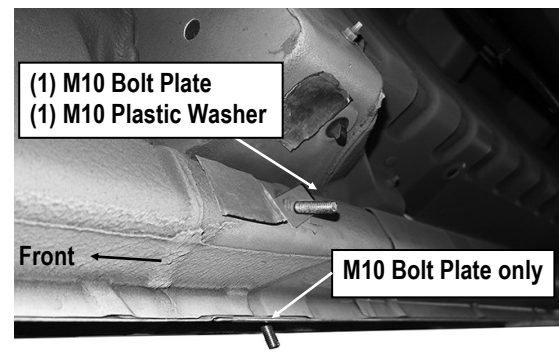

(Fig 7) Passenger Side 3rd Mounting Location

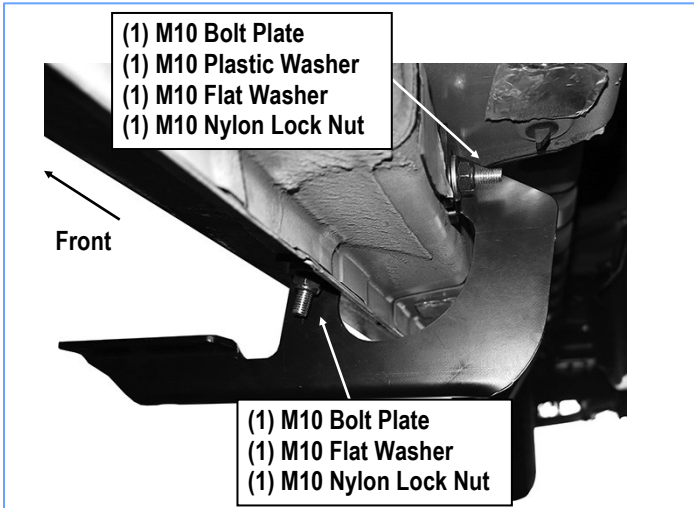

(Fig 8) Passenger Center Mounting Bracket 1 Installed

STEP 6

Locate the passenger side rear mounting location along the bottom of the body, (Fig 9). Insert (1) M10 Bolt Plate at the bottom of the body panel, (Fig 9). Attach the Passenger Rear Mounting Bracket to the installed M10 Bolt Plate with (1) M10 Flat Washer and (1) M10 Nylon Lock Nut, (Fig 14). Line up the mounting plate on the Bracket with the front facing side of the inner body brace, (Fig 12). Do not fully tighten hardware.

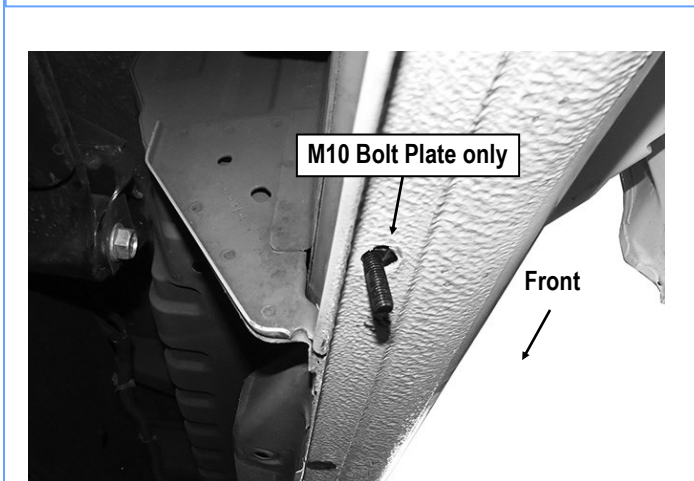

(Fig 9) Passenger Rear Mounting Bracket Location

STEP 7

Once all (4) mounting brackets are installed. Select the passenger side Running Board (the longer one). Slip (4) M6x1-20mm Square Head Bolts into each bottom channel (Fig 10). Carefully position the Running Board onto the (4) Mounting Brackets. Attach the Running Board to each Mounting Bracket with (2) M6X1-20mm Square Head Bolts, (2) M6 Large Flat Washers and (2) M6 Nylon Lock Nuts (Fig 11). Do not fully tighten hardware at this time.

IMPORTANT: Do not slide the Running Board on the Brackets or the bottom surface of the board will be damaged. Level and adjust the Running Board and fully tighten the Bracket to vehicle hardware only. **NOTE:** Line up the front end of the Board with the front of the front door.

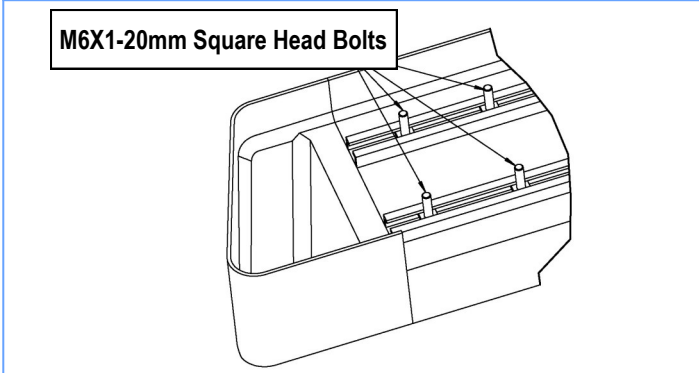

(Fig 10) Slip M6X1-20mm Square Head Bolts Into The Bottom Channels

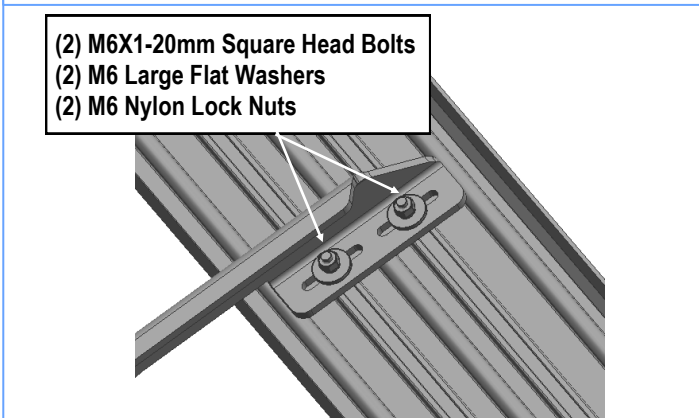

(Fig 11) Running Board Installed Onto Mounting Bracket (Example)



STEP 8

Back to the Passenger Rear Mounting Bracket (**PRM**). With the Running Board level, mark the location of the (2) mounting holes on the Bracket onto the inner body brace, (**Fig 12**). Temporarily remove the Bracket only. Drill (2) 5/16" or 3/8" max holes through the marked locations, (**Fig 13**).

Reinstall the Bracket. Attach Bracket to inner body brace with the included (2) M8X1.25-30mm Hex Bolts, (4) M8 Large Flat Washers, (2) M8 Lock Washers and (2) M8 Hex Nuts, (**Fig 14**). Check Running Board for level, adjust as necessary and fully tighten all hardware.

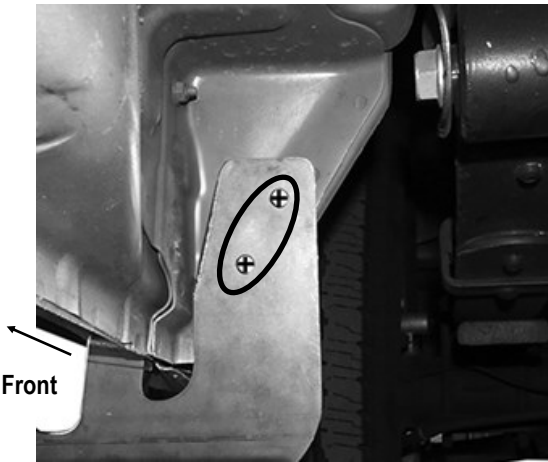

(Fig 12) Mark The Location Of the (2) Mounting Holes

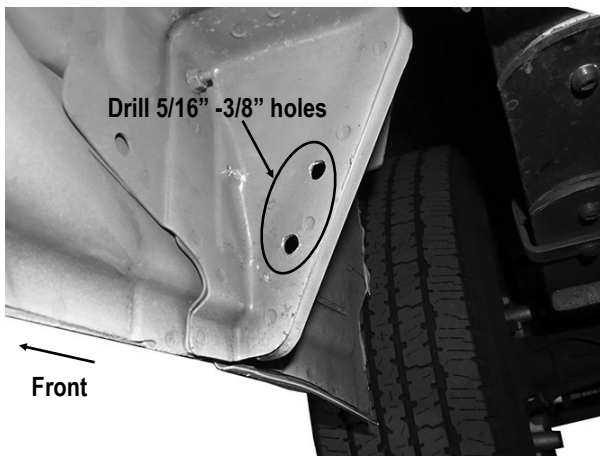

(Fig 13) Drill Holes on Passenger Side Rear Mounting Location

- (2) M8X1.25-30mm Hex Bolts
- (4) M8 Large Flat Washers
- (2) M8 Lock Washers
- (2) M8 Hex Nuts

Front

- (1) M10 Bolt Plate
- (1) M10 Flat Washer
- (1) M10 Nylon Lock Nut

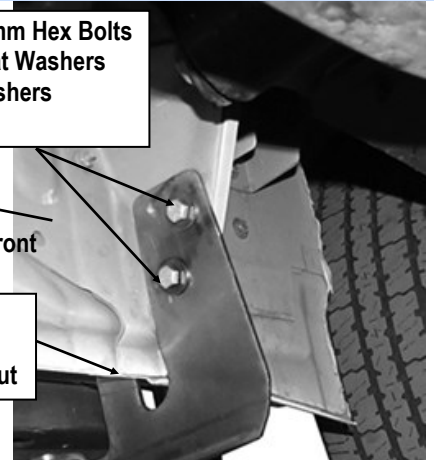

(Fig 14) Passenger Rear Mounting Bracket Complete Installation

STEP 9

Move to the Driver side of the vehicle (**Figs 15 & 16**). Repeat **Steps 1-3** to install the driver side (3) Mounting Brackets (**Figs 17-18**). Do not fully tighten hardware at this time.

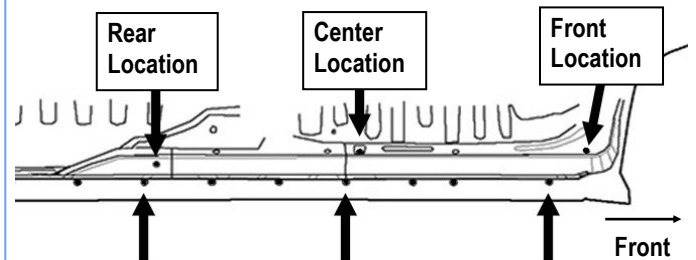

(Fig 15) Driver Side (3) Mounting Locations

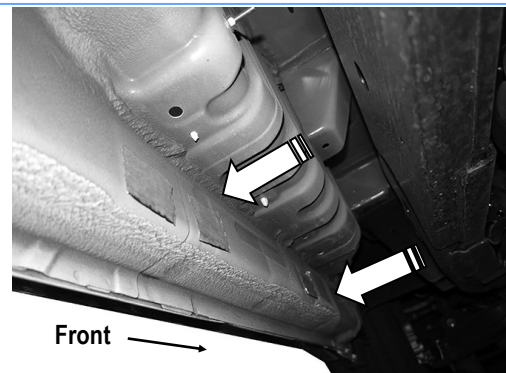

(Fig 16) Driver Side Front & Center Mounting Locations



STEP 10

Select the Driver Side Running Board. Repeat **Step 7** to attach Running Board to the (3) Brackets.

STEP 11

Level and adjust the Running Board and fully tighten all hardware. Installation completed.

Attention

Do periodic inspections to the installation to make sure that all hardware is secure and tight.

In order to protect your bars/boards, please use mild soap/non-abrasive products for cleaning only.

- (1) M10 Bolt Plate
- (1) M10 Plastic Washer
- (1) M10 Flat Washer
- (1) M10 Nylon Lock Nut

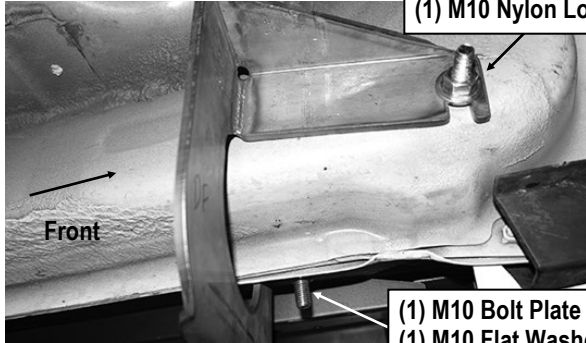

- (1) M10 Bolt Plate
- (1) M10 Flat Washer
- (1) M10 Nylon Lock Nut

(Fig 17) Driver Front Mounting Bracket Installation

- (2) M10 Bolt Plates
- (2) M10 Plastic Washers
- (2) M10 Flat Washers
- (2) M10 Nylon Lock Nuts

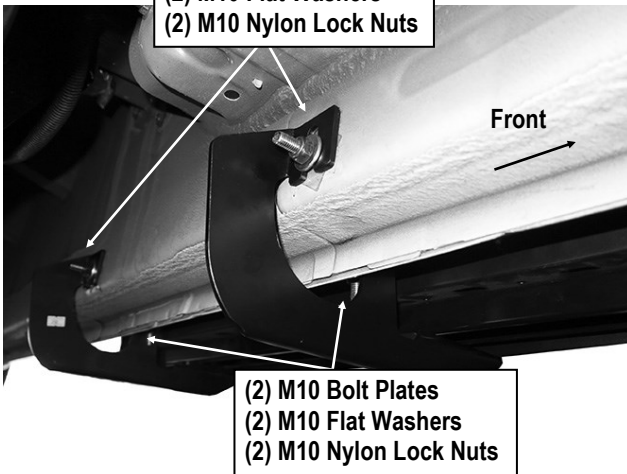

- (2) M10 Bolt Plates
- (2) M10 Flat Washers
- (2) M10 Nylon Lock Nuts

(Fig 18) Driver Center & Rear Mounting Bracket Installation