



iBoard® by APS

PART#: IB-P337Y&H

READ INSTRUCTIONS CAREFULLY BEFORE STARTING INSTALLATION. REMOVE CONTENTS FROM BOX AND VERIFY ALL PARTS ARE PRESENT. ASSISTANCE IS RECOMMENDED.

*ROCKER PANEL MOUNT

*DRILLING IS REQUIRED/ CUTTING IS REQUIRED

Fastener Size	Tightening Torque (ft-lbs)	Required
6mm	6-7	√
8mm	16-18	√
10mm	31-32	√
12mm	56-58	X
14mm	92-94	√

PART LIST

Driver Side Step Bar

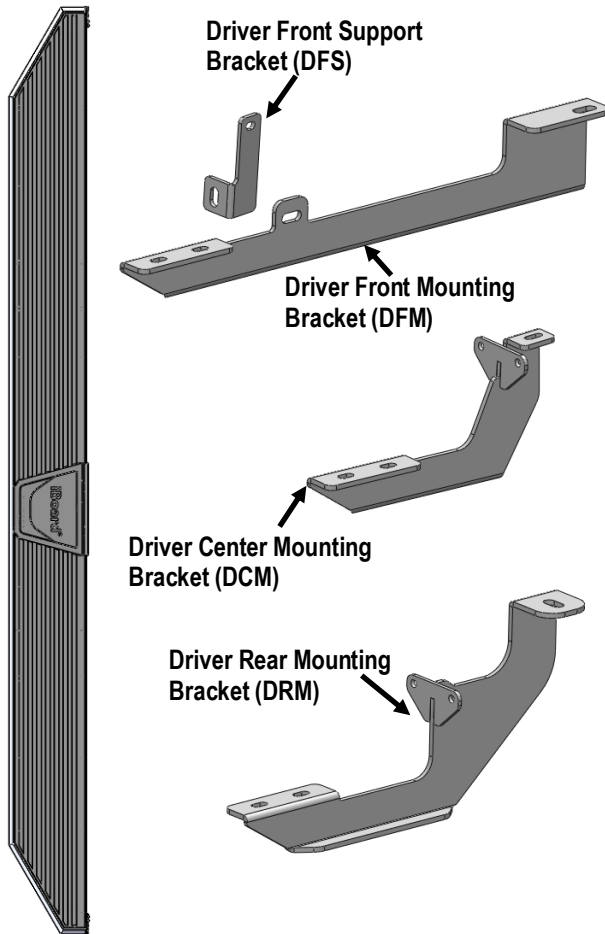

Front



Passenger Side Step Bar

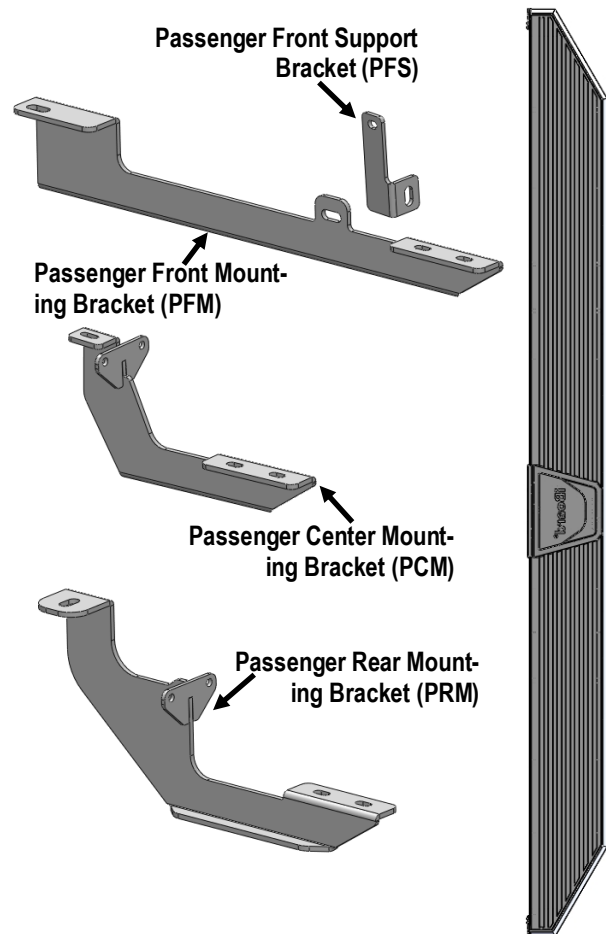



Scan for
Installation Video

Hardware Package A (For Bracket Installation)					
Item	QTY	Description	Item	QTY	Description
1#	2	M10X35 Bolt Plates	8#	2	M8X1.25-25mm Hex Bolts
2#	2	M10X40 Bolt Plates	9#	4	M8 Flat Washers
3#	4	M10 Plastic Washers	10#	2	M8 Nylon Lock Nuts
4#	2	M14 Large Flat Washers	11#	12	M6X1-25mm Hex Bolts
5#	4	M10 Flat Washers	12#	22	M6 Flat Washers
6#	4	M10 Lock Washers	13#	12	M6 Lock Washers
7#	4	M10 Hex Nuts	14#	10	M6 Nylon Lock Nuts

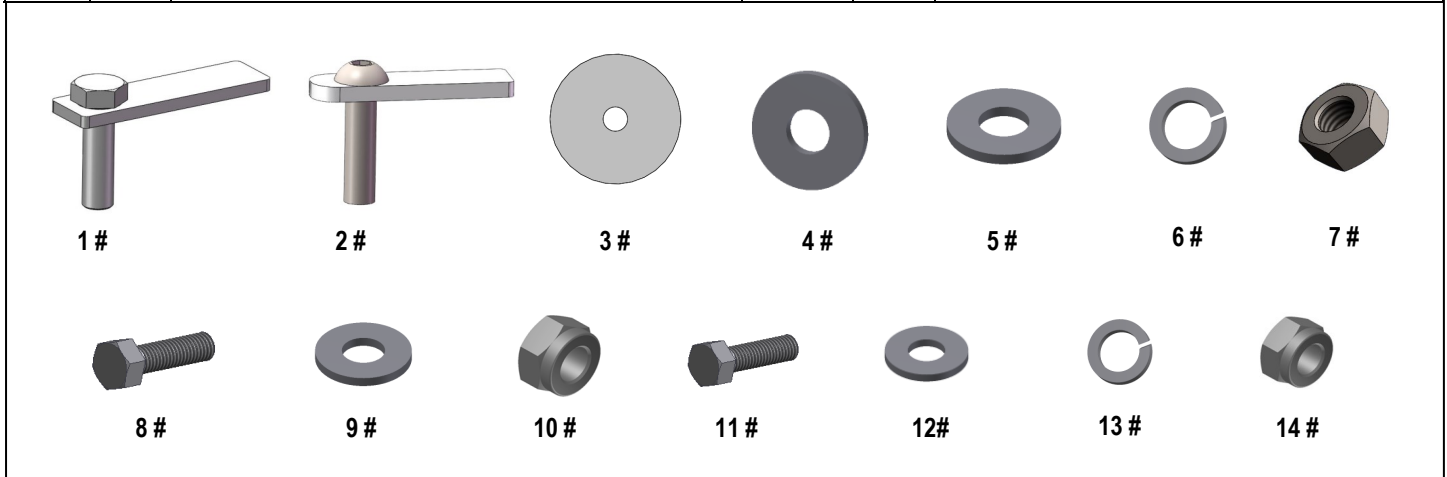

Hardware Package B (For Step Bar Installation)					
Item	QTY	Description	Item	QTY	Description
1#	12	M8X1.25-35mm Carriage Bolts	3#	12	M8 Nylon Lock Nuts
2#	12	M8 Large Flat Washers	4#	6	Sliders (Packed with Mounting Brackets)

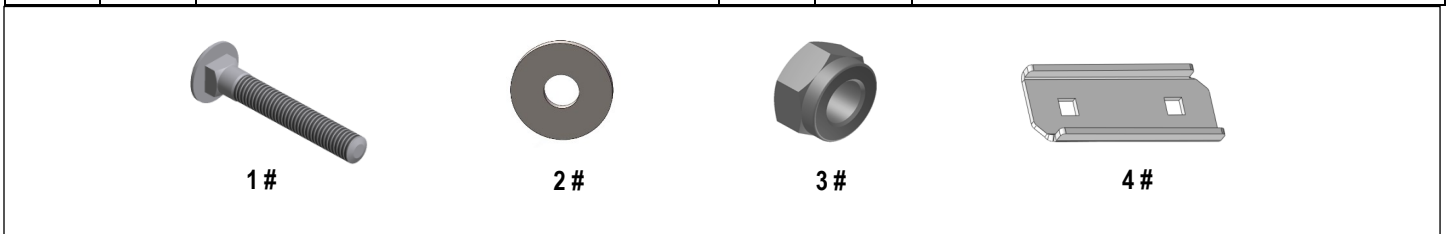



STEP 1

Start installation from the passenger side front of the vehicle. Locate and remove the plastic cover attached to the bottom of the floor panel, (**Fig 1**). Next, locate and remove the rubber plug in the bottom of the inner frame channel, (**Fig 2**).

Insert (1) M10X35 Bolt Plate with (1) M10 Plastic Washer into the hole and thread the Plastic Washer down tight to help hold the Bolt Plate in position, (**Fig 3**).

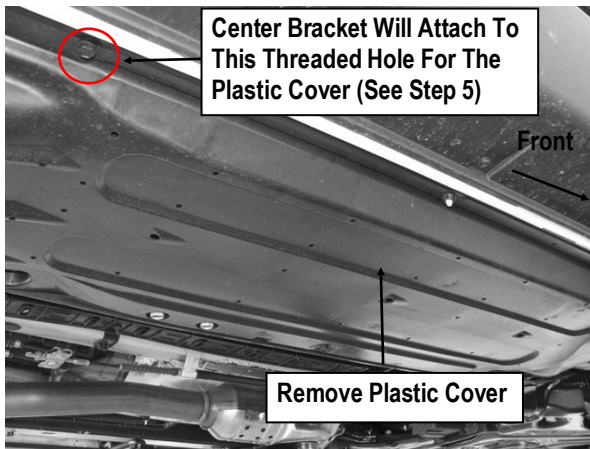

(Fig 1) Passenger Side Front Mounting Location

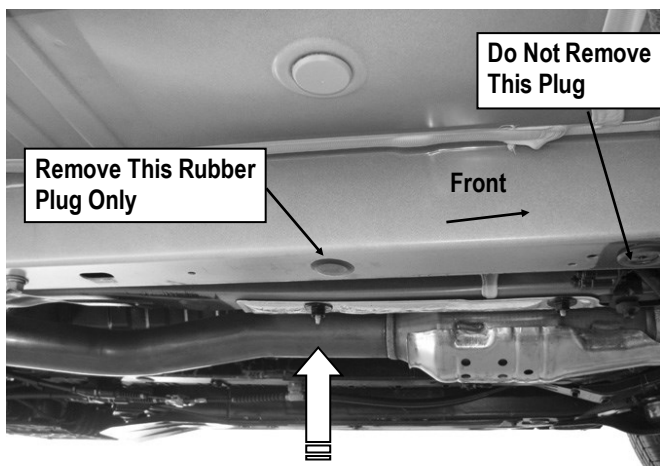

(Fig 2) Passenger Side Front Mounting Location

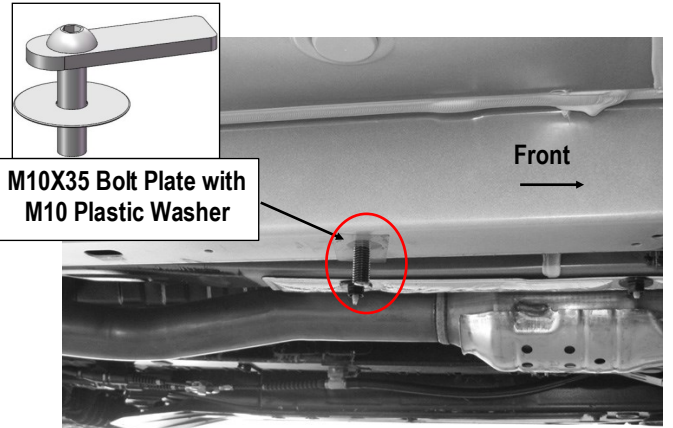

(Fig 3) Insert (1) M10X35 Bolt Plate with (1) M10 Plastic Washer

STEP 2

Select (1) Passenger Front Mounting Bracket (**PFM**) and (1) Passenger Front Support Bracket (**PFS**). Bolt the bent end of the Support Bracket to Passenger Front Mounting Bracket with (1) M8X1.25-25mm Hex Bolt, (2) M8 Flat Washers, (1) M8 Lock Washer and (1) M8 Hex Nut, (**Fig 4**). Do not fully tighten hardware at this time.

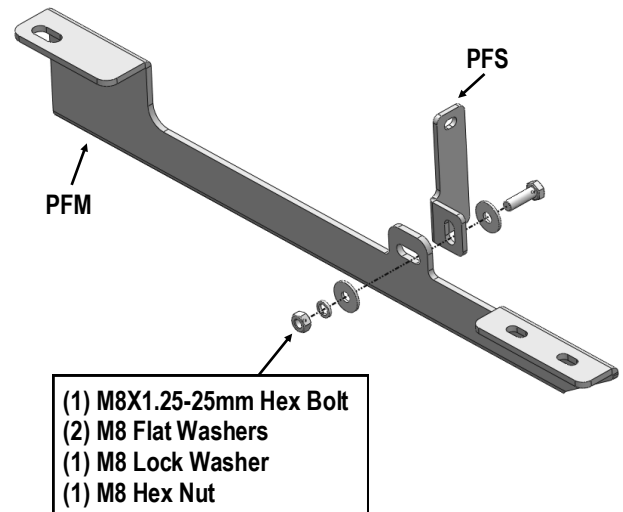

(Fig 4) Passenger Side Front Bracket Assembly



STEP 3

Next, attach the assembled Passenger Front Mounting Bracket to the installed M10X35 Bolt Plate (with M10 Plastic Washer) by using (1) M10 Flat Washer (1) M10 Lock Washer and (1) M10 Hex Nut, (Fig 5). Do not fully tighten hardware at this time.

Line up the mounting tab on the Front Support Bracket with the back of the pinch weld. Use a clamp to temporarily attach the Support Bracket to the pinch weld, (Fig 6).

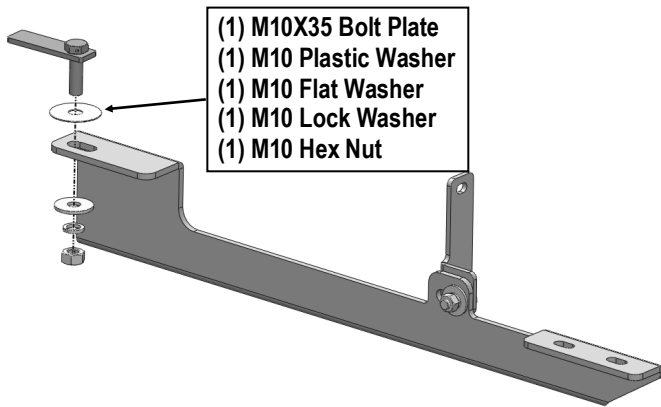

(Fig 5) Passenger Side Front Mounting Bracket Installation

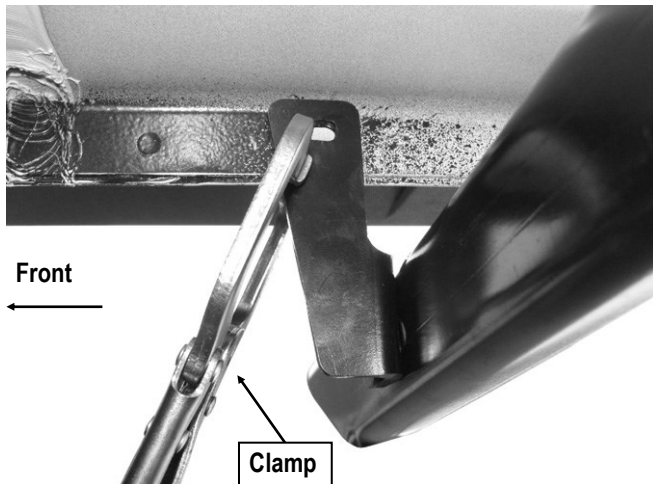

(Fig 6) Use Clamp To Temporarily Hold Front Support Bracket Up To Pinch Weld Until Final Installation

STEP 4

Move to the passenger side center of the vehicle. Locate the last/rear threaded hole in the outer frame channel for the plastic cover removed in **Step 1**, (Fig 1). Select the Passenger Center Mounting Bracket (PCM), bolt the Bracket to the threaded hole with (1) M6X1-25mm Hex Bolt, (1) M6 Lock Washer and (1) M6 Flat Washer, (Fig 7). Do not fully tighten the hardware at this time.

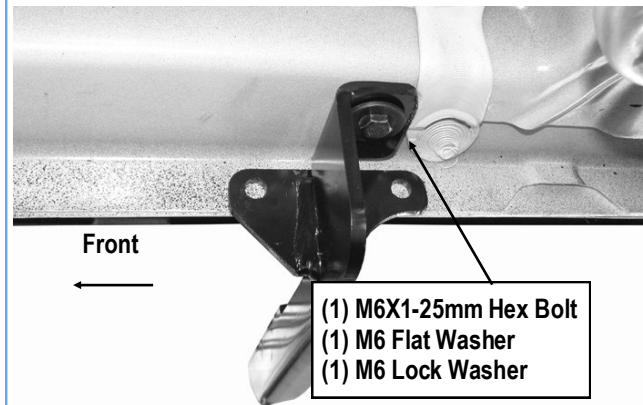

(Fig 7) Passenger Side Center Mounting Bracket Installation

STEP 5

Move to the Passenger side rear of the vehicle, locate the rubber plug in the bottom of the floor panel directly in front of the rear suspension mount, (Fig 8). Remove the plug. Repeat **Step 1** to insert (1) M10X40 Bolt Plate with (1) M10 Plastic Washer into the hole, (Fig 9).

Select the Passenger Rear Mounting Bracket (PRM). Slide (1) M14 Large Flat Washer over the M10X40 Bolt Plate and M10 Plastic Washer, (Fig 10). Then, attach the Passenger Rear Mounting Bracket to the installed M10X40 Bolt Plate with (1) M10 Flat Washer, (1) M10 Lock Washer and (1) M10 Hex Nut, (Fig 11). Do not fully tighten hardware at this time.

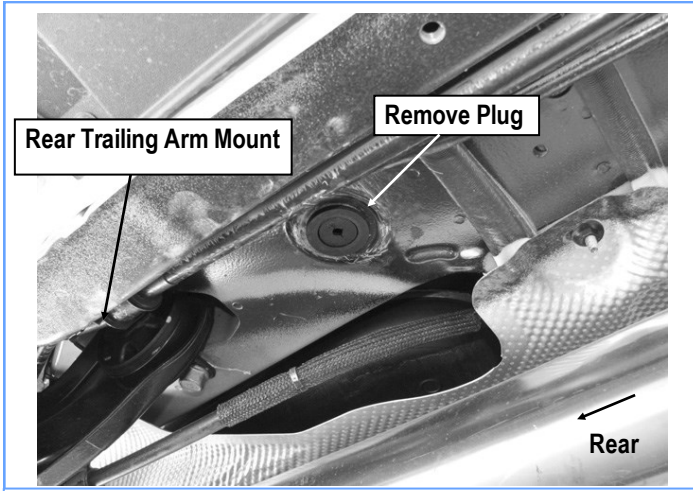

(Fig 8) Passenger Side Rear Mounting Location Pictured

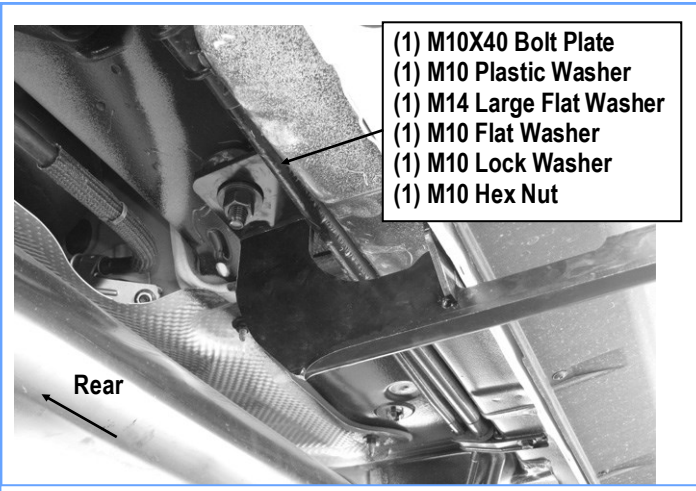

(Fig 11) Passenger Side Rear Mounting Bracket Installation

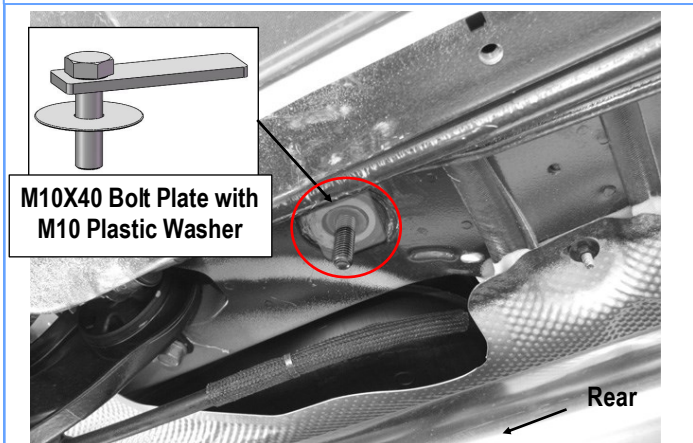

(Fig 9) Insert (1) M10X40 Bolt Plate

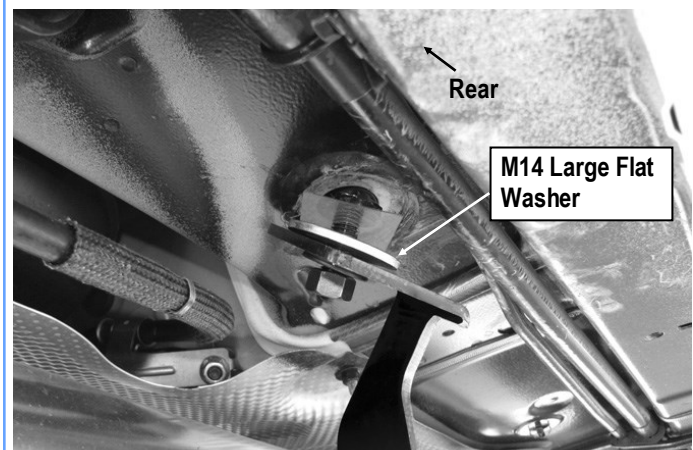

(Fig 10) Insert M14 Large Flat Washer
Between The Bracket And The Body Panel

STEP 6

Push the mounting tab on the Rear Mounting Bracket up tight against the back of the pinch weld. Use a clamp to help hold the Bracket in place if necessary. Do not fully tighten hardware at this time.

STEP 7

Once all (3) Passenger side mounting brackets are installed, then proceed to the Step Bar installation. (Figs 12 & 13)

(1) Select (1) Slider and (2) M8X1.25-35mm Carriage Bolts;

(2) Install (2) M8X1.25-35mm Carriage Bolts in (1) Slider.

(3) Slide the Slider (with carriage bolts) to the **Step Bar**.

(4) Repeat to install the other (2) sliders to the step bar.

(5) Attach the Step Bar (with the Sliders) onto the installed mounting brackets. Position the Sliders to the installed brackets. Secure the Step Bar to the installed Brackets by using (6) M8 Large Flat Washers and (6) M8 Nylon Lock Nuts and (3) Sliders, (Fig 13). Do not fully tighten hardware at this time.

Note: The Sliders are packed with the Mounting Brackets.

Level and adjust the Step Bar and fully tighten all hardware.

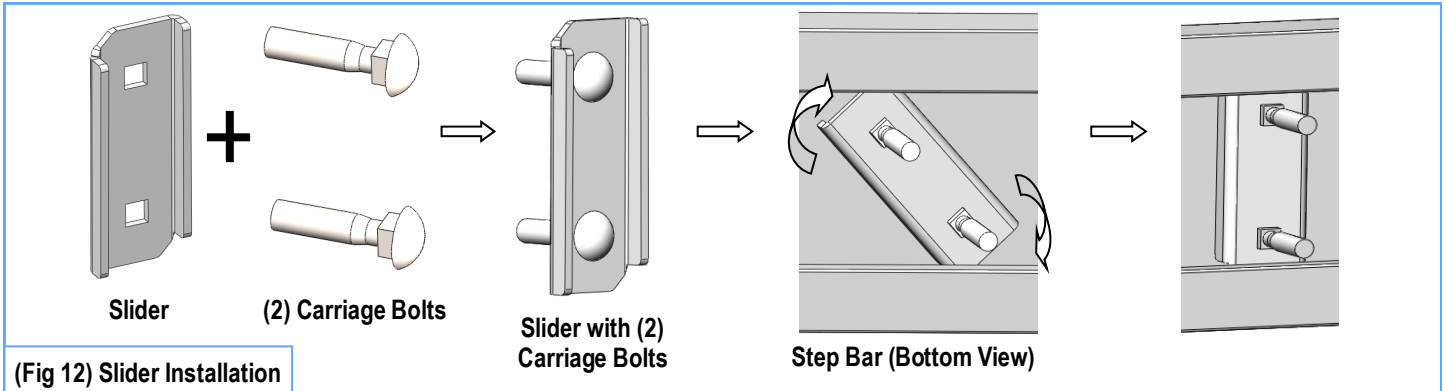

(Fig 12) Slider Installation

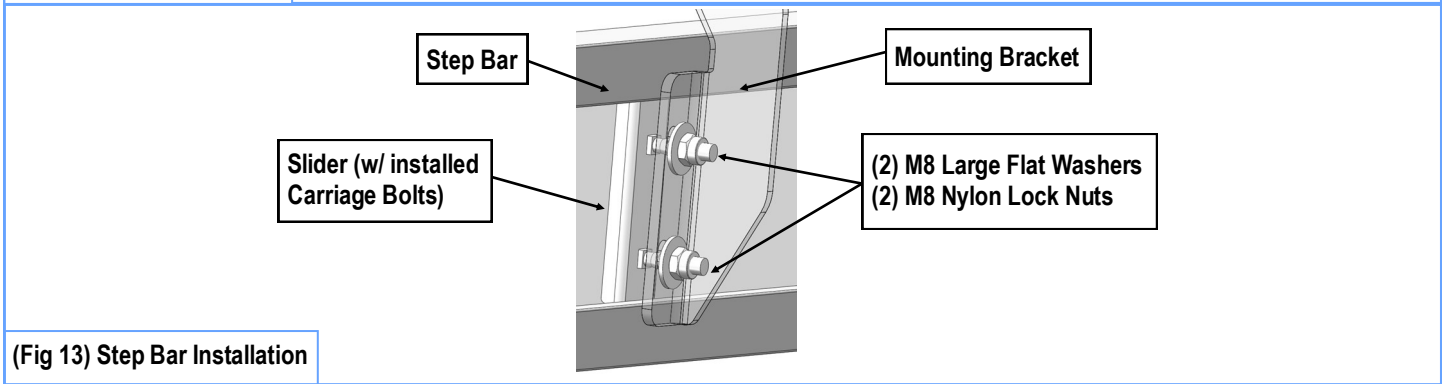

(Fig 13) Step Bar Installation

STEP 8

Level and adjust the Step Bar properly and tighten all Bracket to vehicle hardware. Make sure that the Step Bar is level and that the mounting holes in the Brackets are not too close to the bottom edge of the pinch weld before marking any of the holes for the Brackets, (Fig 14).

Mark the front, center and rear Support Bracket slot locations onto the back of the pinch weld, (Fig 15). Temporarily remove the Step Bar and Brackets. Remove the screws attaching the plastic rocker cover to the bottom of the body. Drill 1/4" holes, (5 total), through the pinch weld at the previously marked front, center and rear Bracket locations.

IMPORTANT: Be careful to avoid damaging the outer plastic rocker cover.

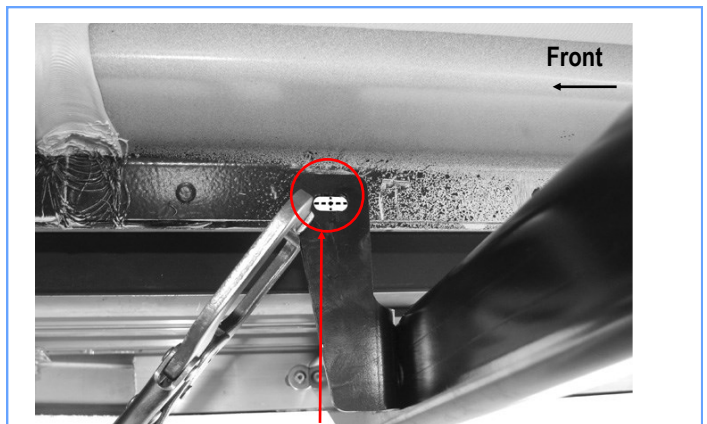

(Fig 14) Marking And Drilling Holes (Passenger Side Front Mounting Bracket)

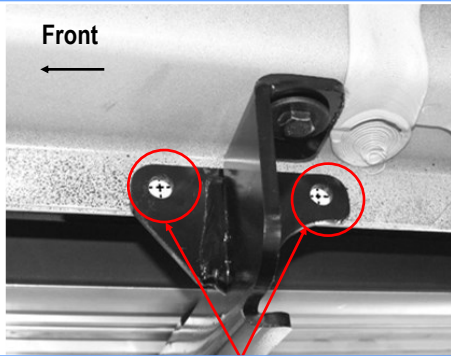

(Fig 15) Marking And Drilling Holes (Passenger Side Center Mounting Bracket)

STEP 9

Remove the Passenger Front Support Bracket (PFS) from the Front Mounting Bracket. Bolt the Support Bracket to the back of the pinch weld with (1) M6X1-25mm Hex Bolt, (2) M6 Flat Washers and (1) M6 Nylon Lock Nut. Do not fully tighten hardware at this time.

STEP 10

Move to the center location and reinstall the Center Mounting Bracket. Bolt the mounting tab on the Bracket to the pinch weld with (2) M6X1-25mm Hex Bolts, (4) M6 Flat Washers and (2) M6 Nylon Lock Nuts. Do not fully tighten hardware at this time. Move to the rear Bracket location. Reinstall the Bracket and repeat to attach the rear support tab on the Bracket, (Fig 16).

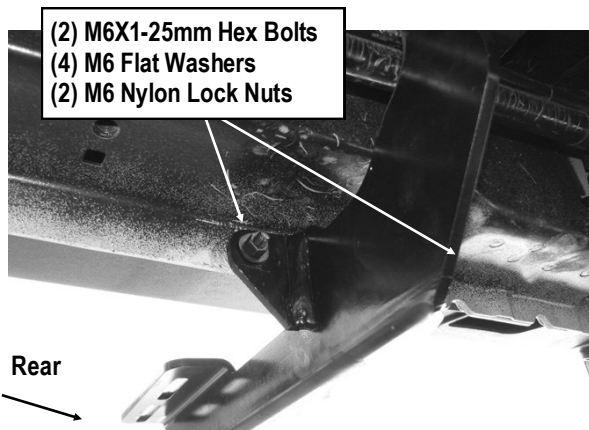

(Fig 16) Driver Side Rear Bracket Installation

STEP 11

Reattach the lower rocker cover with the factory screws. **NOTE:** Trim the edge of the rocker cover around the 6mm Hex Bolts in pinch weld as required for proper fit and wrench access.

STEP 12

Temporarily attach the Front Mounting Bracket to the Front Support Bracket and Bolt Plate. Hold the large plastic cover removed in **Step 1** up against the bottom of the front Bracket. Mark the location of the Bracket onto the inside of the cover, (Fig 17). Remove the front Bracket. Cut a slot in the cover with a sharp knife or hacksaw blade, (Fig 18). **IMPORTANT:** Only remove material necessary to clear the front Bracket. Do not cut through the inner or outer edge of the cover.

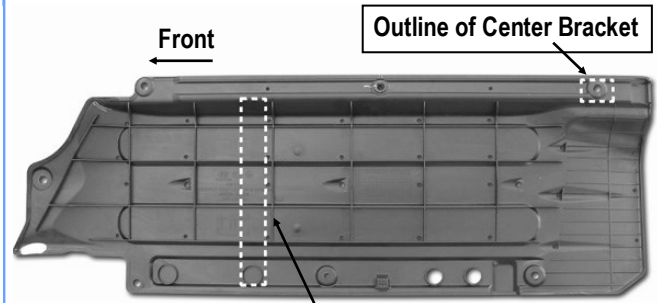

Fig 17

After Step Bar has been properly aligned and adjusted, hold the plastic cover up in place against the front Bracket. Trace the Bracket location onto the cover. Cut slot out of cover to clear front Bracket.

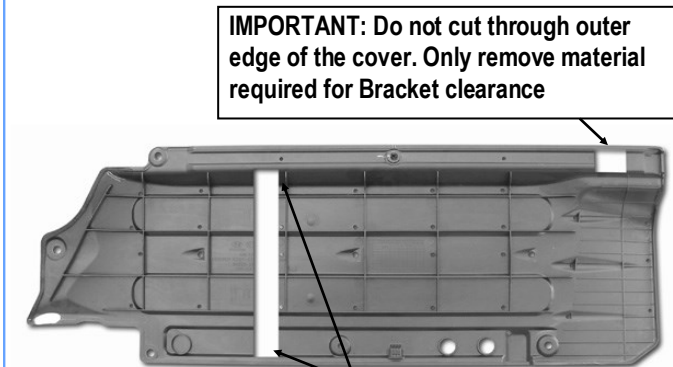

Fig 18



STEP 13

Next, locate the hole in the cover for the Center Mounting Bracket mounting location. Trace the Bracket outline onto the cover. Cut a section out of the cover to clear the mounting tab on the Bracket, **(Fig 18)**. **IMPORTANT:** Be very careful and do not cut complete through the outer edge. Remove the center Bracket and reinstall the plastic cover with the factory hardware.

Reinstall the front and center Brackets.

STEP 14

Reinstall the Step Bar. Level and adjust the Step Bar and fully tighten all hardware.

STEP 15

Repeat **Steps 1-14** for other side Step Bar installation. The installation is completed.

Attention

Do periodic inspections to the installation to make sure that all hardware is secure and tight.

In order to protect your bars/boards, please use mild soap/non-abrasive products for cleaning only.