

iBoard®



Scan for
Installation Video

iBoard® by APS

PART#: IB-R962

READ INSTRUCTIONS CAREFULLY BEFORE STARTING INSTALLATION. REMOVE CONTENTS FROM BOX AND VERIFY ALL PARTS ARE PRESENT. ASSISTANCE IS RECOMMENDED.

*ROCKER PANEL MOUNT
*DRILLING IS REQUIRED

Fastener Size	Tightening Torque (ft-lbs)	Required
6mm	6-7	√
8mm	16-18	√
10mm	31-32	X
12mm	56-58	X
14mm	92-94	X

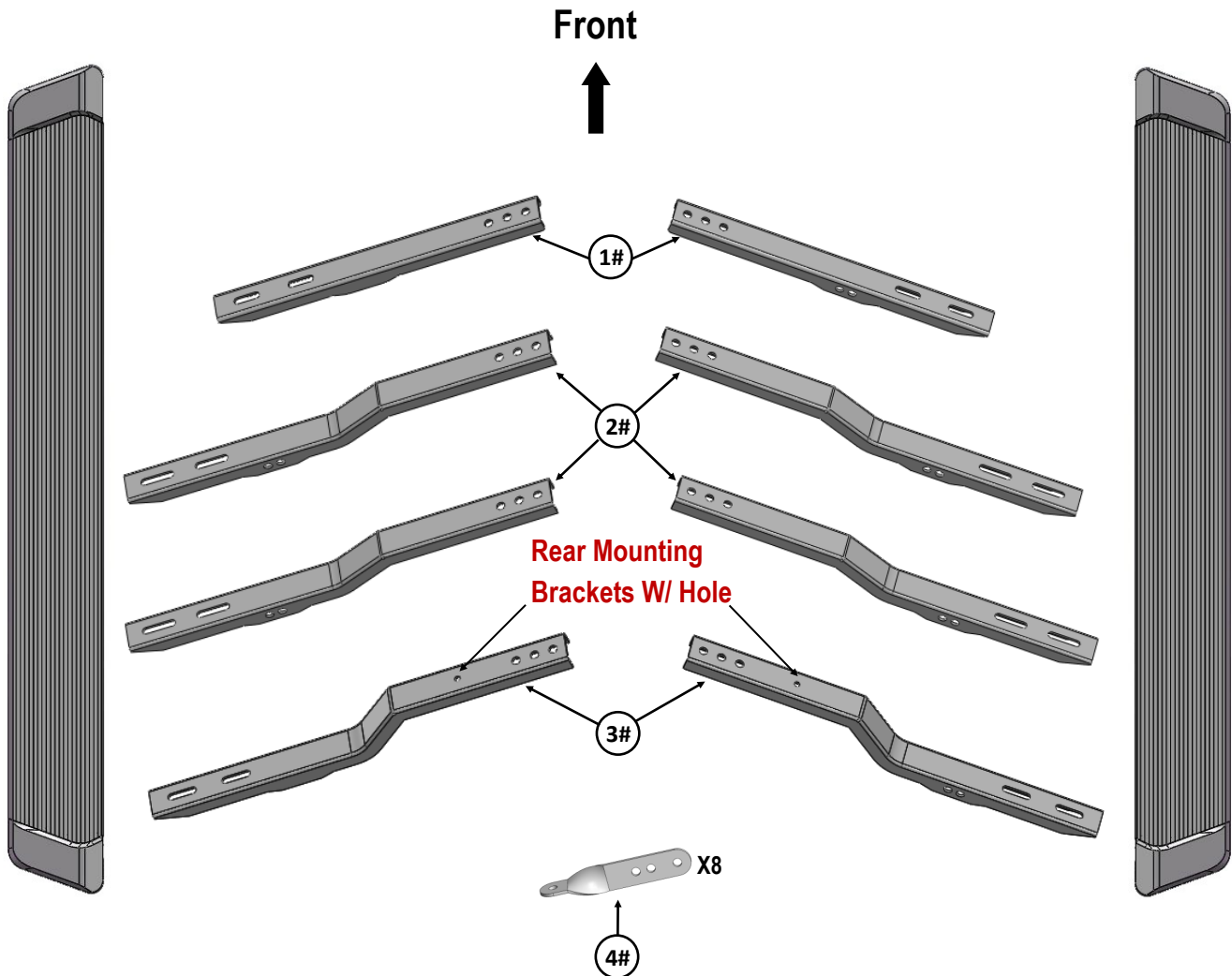

Customer Support: info@iboardauto.com



Scan for
Installation Video

Hardware Package A (For Bracket Installation)					
Item	QTY	Description	Item	QTY	Description
1#	2	Driver / Passenger Front Mounting Brackets	5#	16	M8X1.25-20mm Hex Bolts
2#	4	Driver / Passenger Center Mounting Brackets	6#	32	M8 Flat Washers
3#	2	Driver / Passenger Rear Mounting Brackets	7#	16	M8 Nylon Lock Nuts
4#	8	Support Brackets	8#	16	ST6.3x22mm Hex Self Tapping Screws

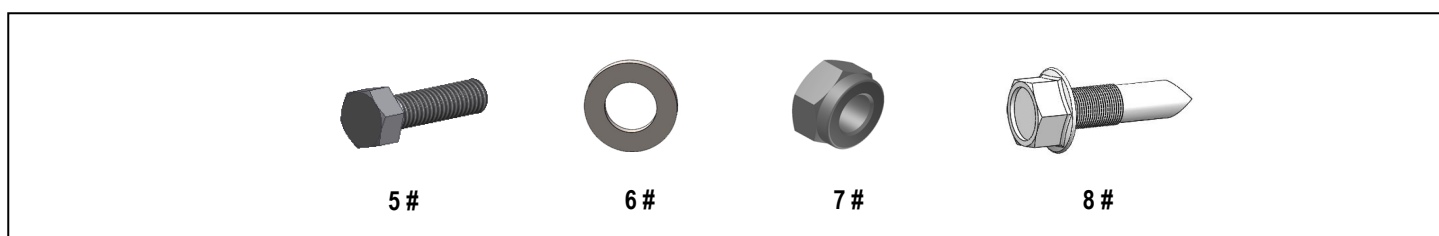

Hardware Package B (For Step Bar Installation)					
Item	QTY	Description	Item	QTY	Description
1#	16	M6X1-20mm Square Head Bolts	3#	16	M6 Nylon Lock Nuts
2#	16	M6 Large Flat Washers			

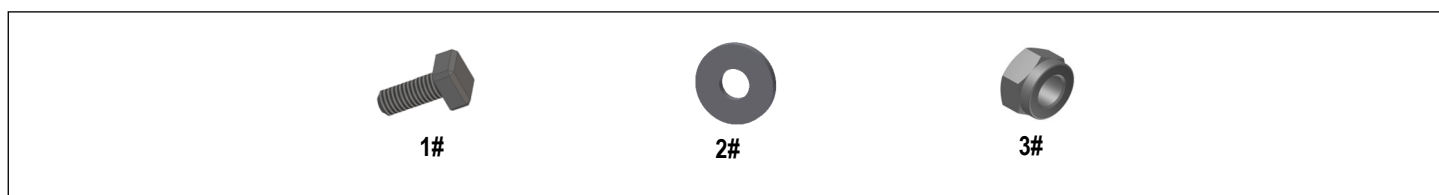



STEP 1

Start installing from the driver side of the vehicle, drill 5/16" holes on pinch weld as shown (Both sides), (Fig 1).

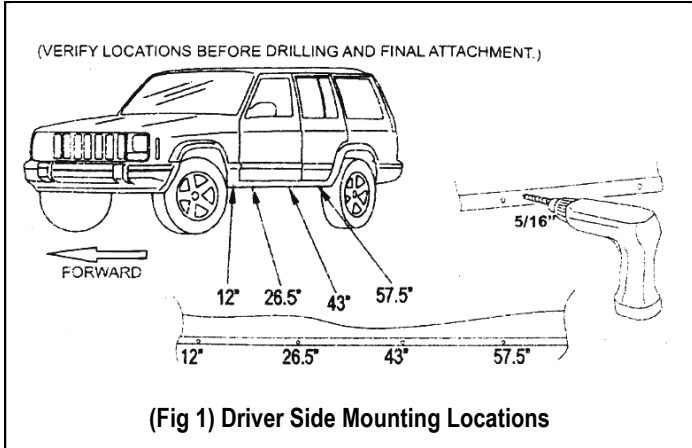

STEP 2

Assemble (1) Driver Front Mounting Bracket and Support Bracket with (1) M8X1.25-20mm Hex Bolt, (2) M8 Flat Washers and (1) M8 Nylon Lock Nut, (Fig 2). Do not fully tighten at this time.

Then attach the assembled Driver Front Mounting Bracket to vehicle with (2) ST6.3x22mm Hex Self Tapping Screws, (1) M8X1.25-20mm Hex Bolt, (2) M8 Flat Washers and (1) M8 Nylon Lock Nut, (Fig 3). Do not fully tighten at this time.

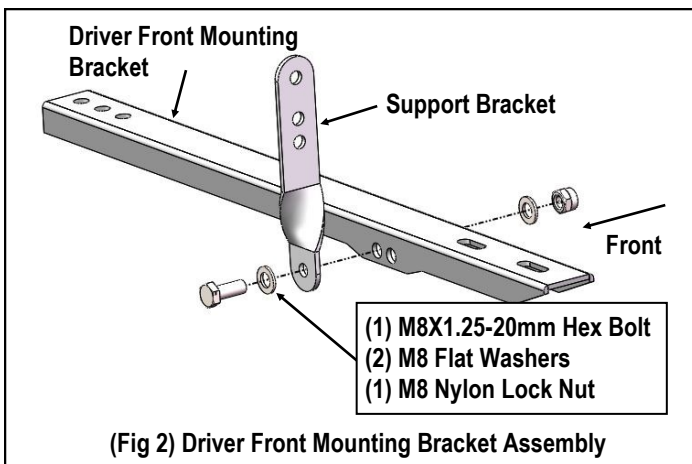

- (1) M8X1.25-20mm Hex Bolt
- (2) M8 Flat Washers
- (1) M8 Nylon Lock Nut

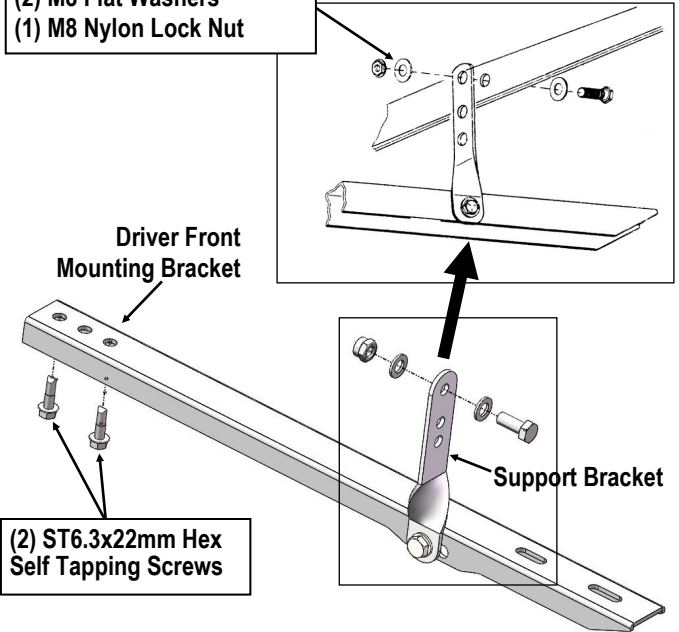

STEP 3

Move to driver side other (3) Mounting locations. Repeat **Steps 1-2** for Mounting Bracket and Support Bracket assembly and installation. Don't fully tighten hardware at this time.

STEP 4

Once all (4) brackets have been installed. Select a Running Board. Slip (4) M6X1-20mm Square Head Bolts into each bottom channel (Fig 4). Carefully position the Running Board onto the (4) Mounting Brackets. Attach the Running Board to each Mounting Bracket with (2) M6X1-20mm Square Head Bolts, (2) M6 Large Flat Washers and (2) M6 Nylon Lock Nuts (Fig 5). Do not fully tighten at this time.

IMPORTANT: Do not slide the Running Board on the Brackets or the bottom surface of the board will be damaged.



M6X1-20mm Square Head Bolts

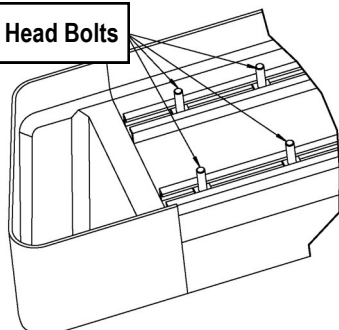

(Fig 4) Slip M6X1-20mm Square Head Bolts Into
The Bottom Channels

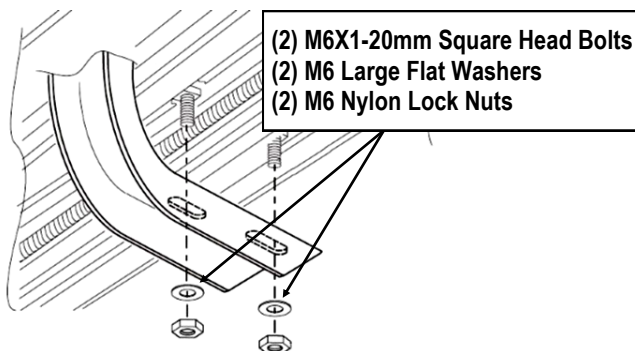

(Fig 5) Running Board Installed Onto Mounting Bracket

STEP 5

Level and adjust the Running Board and fully tighten all hardware.

Important: Please follow the recommended Tightening Torques shown in the table on page 1. Don't over tighten, or the nuts/bolts will be damaged.

STEP 6

Repeat **Steps 1-5** for the other side Running Board installation. The installation is completed.

Attention

Do periodic inspections to the installation to make sure that all hardware is secure and tight.

In order to protect your bars/boards, please use mild soap/non-abrasive products for cleaning only.