



iBoard® Series

INSTALLATION INSTRUCTIONS

PART#: IB-R027

BEFORE INSTALLATION

REMOVE CONTENTS FROM BOX. VERIFY ALL PARTS ARE PRESENT. READ INSTRUCTIONS CAREFULLY BEFORE STARTING INSTALLATION. ASSISTANCE IS RECOMMENDED. THANK YOU FOR CHOOSING OUR PRODUCT!

These instructions are provided for reference only. We strongly recommend installation by a professional installer for the best results. We are not responsible for any damage caused during installation.

***ROCKER PANEL MOUNT**

***NO DRILLING REQUIRED**

Torque Value

Fastener Size	Tightening Torque (ft-lbs)	Required
6mm	6-7	√
8mm	16-18	√
10mm	31-32	X
12mm	56-58	X
14mm	92-94	X



Scan for
Installation Video

Mounting Bracket List			
Item	QTY	Bracket Label	Description
1#	2	DFM	Mounting Bracket for Driver Front/ Passenger Rear
2#	2	DFB	Bar Bracket for Driver Front/ Passenger Rear
3#	2	PFM	Mounting Bracket for Passenger Front /Driver Rear
4#	2	PFB	Bar Bracket for Passenger Front /Driver Rear

PART LIST

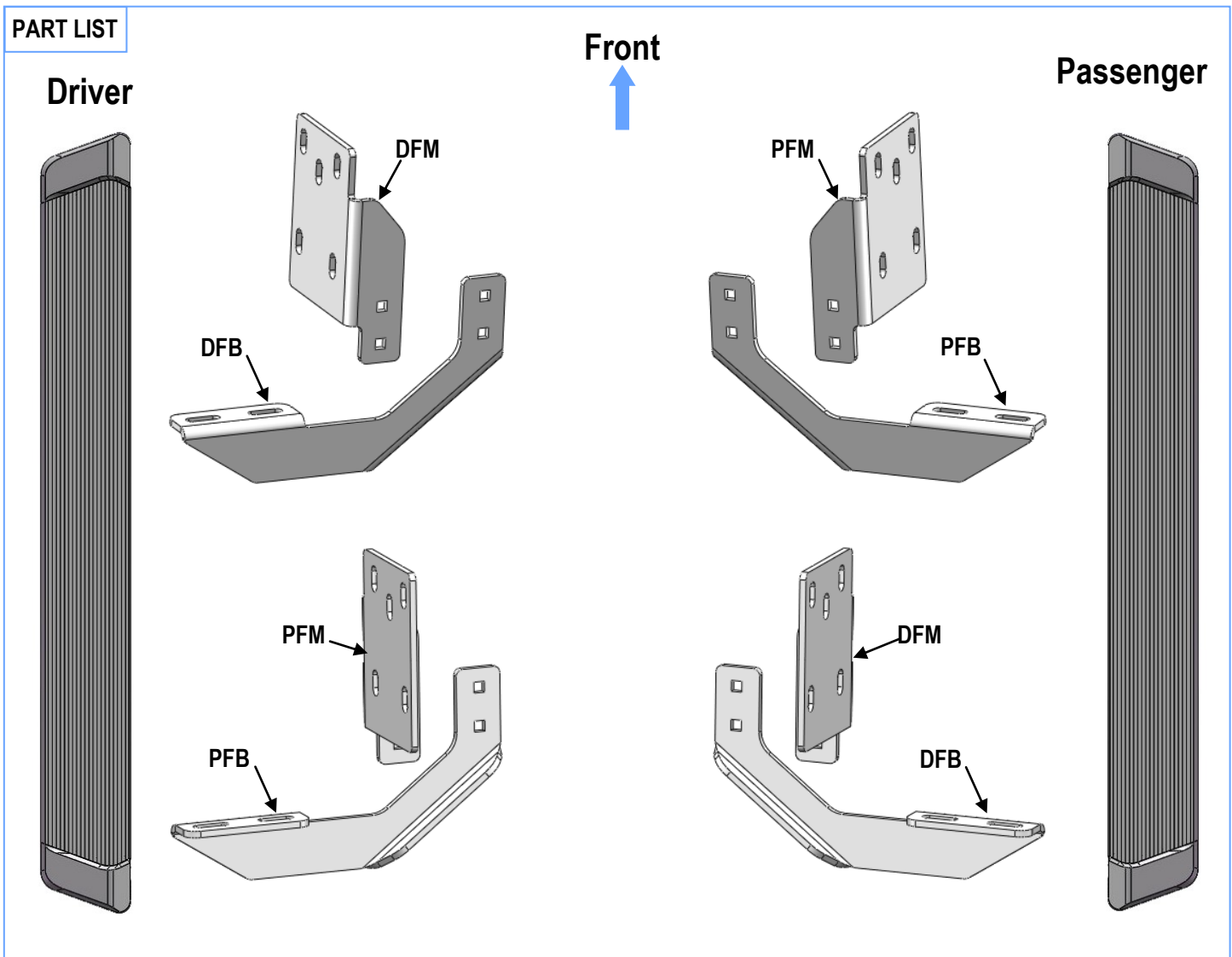





Scan for
Installation Video

Hardware Package A (For Bracket Installation)					
Item	QTY	Description	Item	QTY	Description
A1	12	M8X1.25-30mm Hex Bolt	A5	8	M8X1.25-25 Carriage Bolts
A2	12	M8 Large Flat Washers	A6	8	M8 Flat Washers
A3	12	M8 Lock Washers	A7	8	M8 Nylon Lock Nuts
A4	8	M8 Clip Nuts			



A1

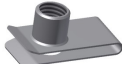

A2

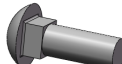
A3



A4



A5

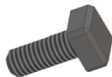

A6

A7

Hardware Package B (For Running Board Installation)					
Item	QTY	Description	Item	QTY	Description
B1	8	M6X1-20mm Square Head Bolts	B3	8	M6 Nylon Lock Nuts
B2	8	M6 Large Flat Washers			

B1

B2

B3



STEP 1: Assemble the Driver Side Mounting Bracket

1. Assemble the Driver Front Mounting Bracket (DFM+DFB) (Fig 1) with:

- (2) A5 (M8X1.25-25 Carriage Bolts)
- (2) A6 (M8 Flat Washers)
- (2) A7 (M8X1.25 Nylon Lock Nuts)

Note: Driver Front and Passenger Rear Mounting Brackets (DFM+DFB) are universal.

2. Repeat to assemble the Driver Rear Mounting Bracket (PFM+PFB) (Fig 2).

Note: Driver Rear and Passenger Front Mounting Brackets (PFM+PFB) are universal.

Do not fully tighten hardware at this time.

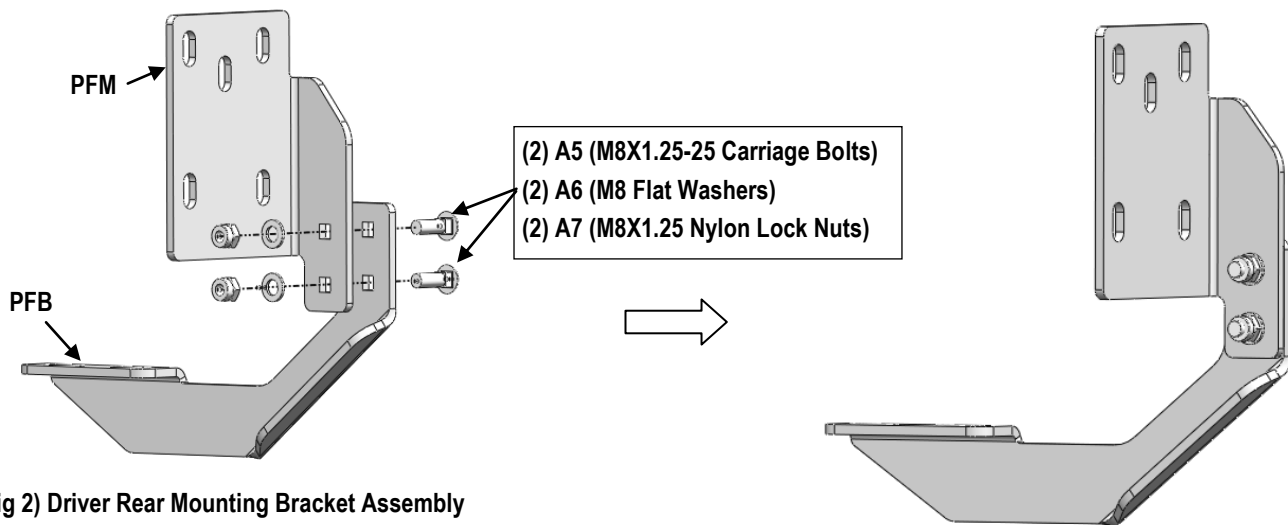
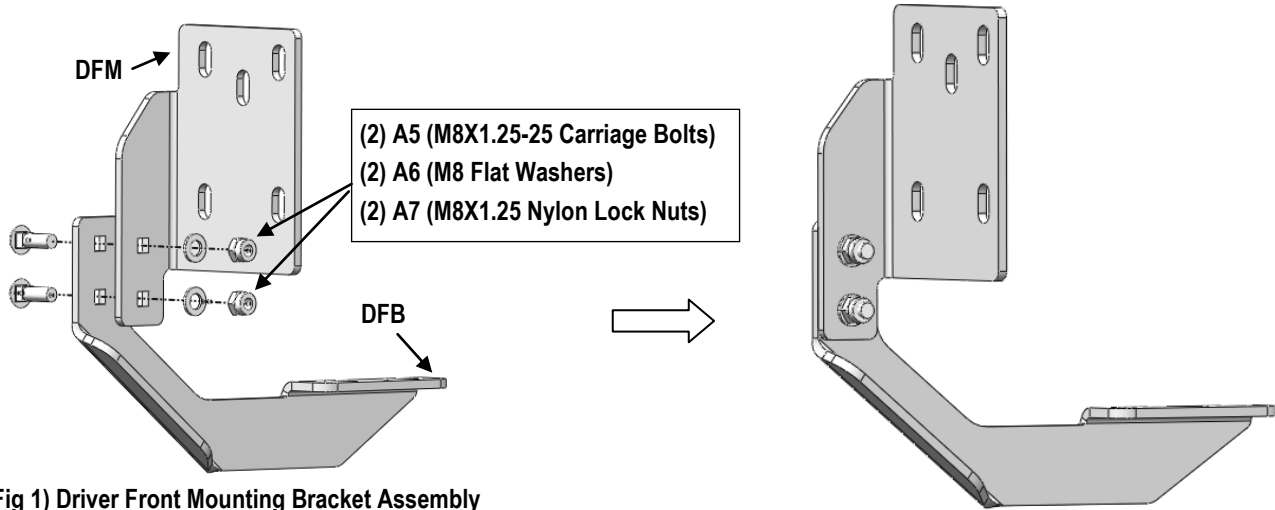



STEP 2: Locate Driver Side Front Mounting Location

- Start installation from the driver side front of the vehicle.
- Locate on the backside of the rocker panel (3) mounting holes where the plastic fascia is cut out.
- Select (2) A4 (M8 Clip Nuts), line up the Clip Nuts with the holes.
- Locate a threaded hole above the clip nuts on the rocker panel.
- Remove plug to expose threaded hole if equipped.

NOTE: Threaded nut on Clip nut must face inside of the side panel. (Fig 3)

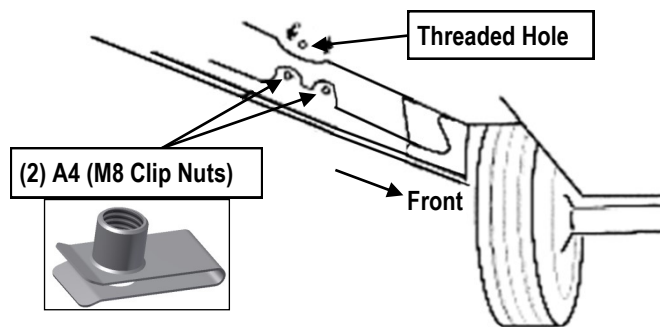

(Fig 3) Driver Side Front Mounting Bracket Installation

STEP 3: Driver Front Mounting Bracket Installation

1. Attach the Assembled Driver Front Mounting Bracket (**DFM+DFB**) to the installed (2) A4 (M8 Clip Nuts) (**Fig 4**) with:
 - (2) A1 (M8X1.25-30mm Hex Bolts)
 - (2) A3 (M8 Lock Washers)
 - (2) A2 (M8 Large Flat Washers)
2. Attach the Assembled Driver Front Mounting Bracket (**DFM+DFB**) to the threaded hole (**Fig 4**) with:
 - (1) A1 (M8X1.25-30mm Hex Bolt)
 - (1) A3 (M8 Lock Washer)
 - (1) A2 (M8 Large Flat Washer)

Do not fully tighten hardware at this time.

STEP 4: Driver Rear Mounting Bracket Installation

Move to the Driver Side Rear Mounting Location.

Repeat **Steps 2&3** to install the Driver Rear Mounting Bracket (**PFM+PFB**) (**Fig 5**).

Do not fully tighten hardware at this time.

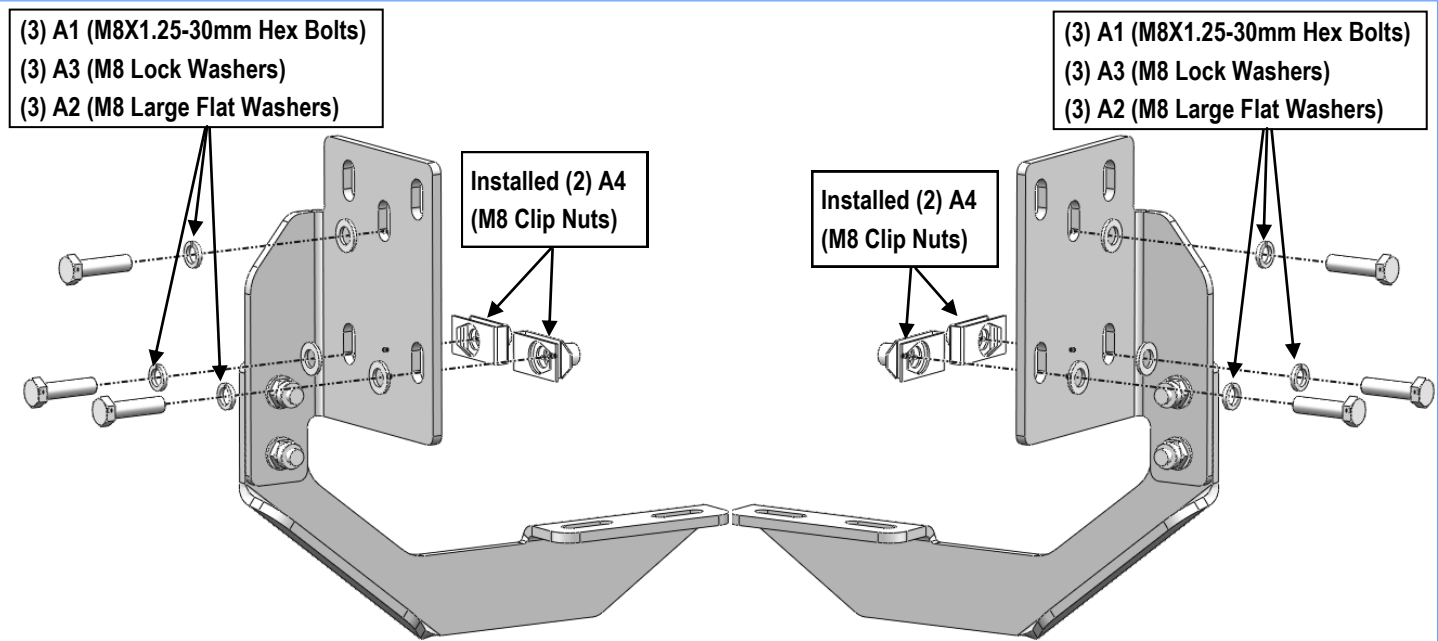

(Fig 4) Driver Front Mounting Bracket Installation

(Fig 5) Driver Rear Mounting Bracket Installation

STEP 5: Driver Side Running Board Installation

Once all (2) mounting brackets are installed, then proceed to the Running Board installation.

- (1) Select a Running Board. Slide (2) B1 M6X1-20mm Square Head Bolts into each bottom channel (Fig 6).
- (2) Carefully position the Running Board onto the (2) Mounting Brackets.
- (3) Attach the Running Board to each Mounting Bracket (Fig 7) with:
 - (2) B1 (M6X1-20mm Square Head Bolts)
 - (2) B2 (M6 Large Flat Washers)
 - (2) B3 (M6 Nylon Lock Nuts)

Note: Do not slide the Running Board on the Brackets or the bottom surface of the board will be damaged.



M6X1-20mm Square Head Bolts

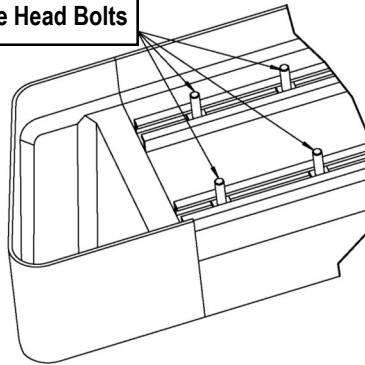

(Fig 6) Slip M6X1-20mm Square Head Bolts Into The Bottom Channels

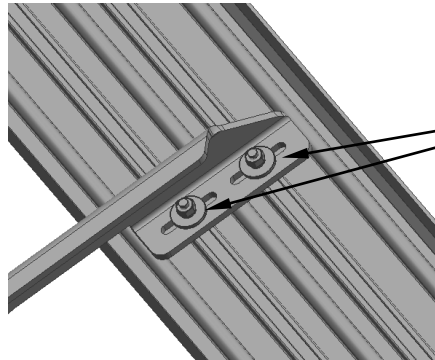

(2) B1 (M6X1-20mm Square Head Bolts)
(2) B2 (M6 Large Flat Washers)
(2) B3 (M6 Nylon Lock Nuts)

(Fig 7) Running Board Installed Onto Mounting Bracket

STEP 6: Driver Side Running Board Adjustment

- Level and adjust the assembled Running Board properly.
- Tighten all 6mm hardware with 6-7 ft-lbs torque and 8mm hardware with 16-18 ft-lbs torque.

STEP 7: The Other Side Running Board Installation

Repeat **Steps 1-6** for the Other Side Running Board Installation.
And then installation is completed!!!

Attention

Do periodic inspections to the installation to make sure that all hardware is secure and tight.
In order to protect your bars/boards, please use mild soap/non-abrasive products for cleaning only.