

iBoard®



Scan for
Installation Video

iBoard® by APS

PART#: IB-R924/R925

READ INSTRUCTIONS CAREFULLY BEFORE STARTING INSTALLATION. REMOVE CONTENTS FROM BOX AND VERIFY ALL PARTS ARE PRESENT. ASSISTANCE IS RECOMMENDED.

*ROCKER PANEL MOUNT
*NO DRILLING REQUIRED

Fastener Size	Tightening Torque (ft-lbs)	Required
6mm	6-7	√
8mm	16-18	√
10mm	31-32	X
12mm	56-58	X
14mm	92-94	X

Driver

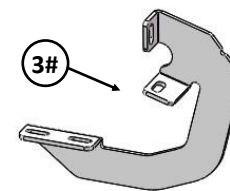
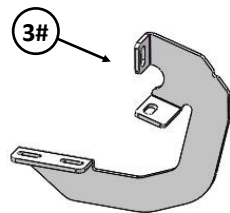
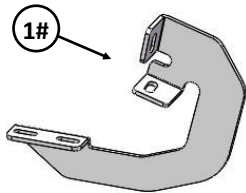
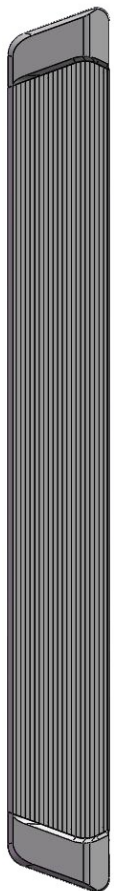

Front

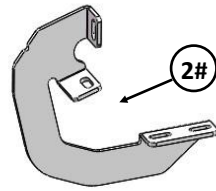
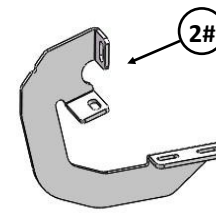
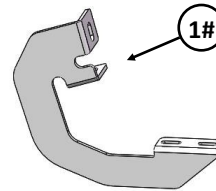

Passenger





Hardware Package A (For Bracket Installation)					
Item	QTY	Description	Item	QTY	Description
1#	2	Driver/Passenger Front Mounting Brackets	5#	18	M8 Large Flat Washers
2#	2	Passenger Center/Rear Mounting Brackets	6#	12	M8 Lock Washers
3#	2	Driver Center/Rear Mounting Brackets	7#	6	M8 Hex Nuts
4#	12	M8X1.25-25mm Hex Bolts	8#	6	ST8x25mm Hex Self Tapping Screws

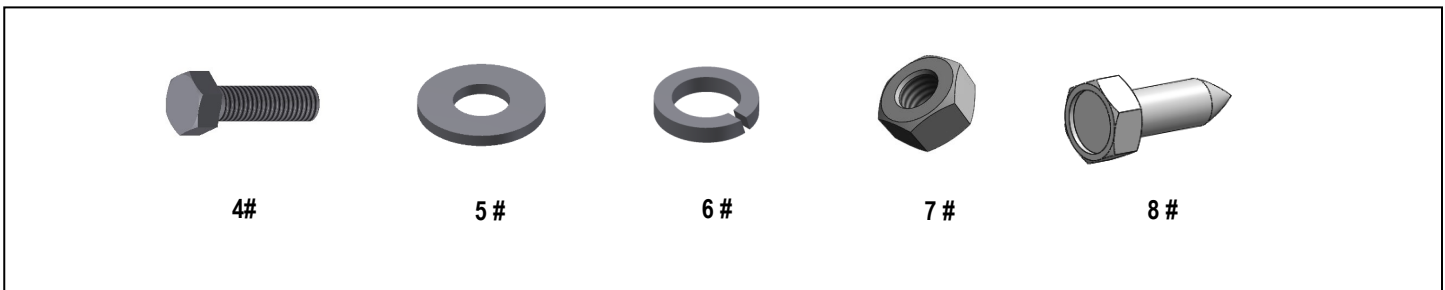

Hardware Package B (For Step Bar Installation)					
Item	QTY	Description	Item	QTY	Description
1#	12	M6X1-20mm Square Head Bolts	3#	12	M6 Nylon Lock Nuts
2#	12	M6 Large Flat Washers			

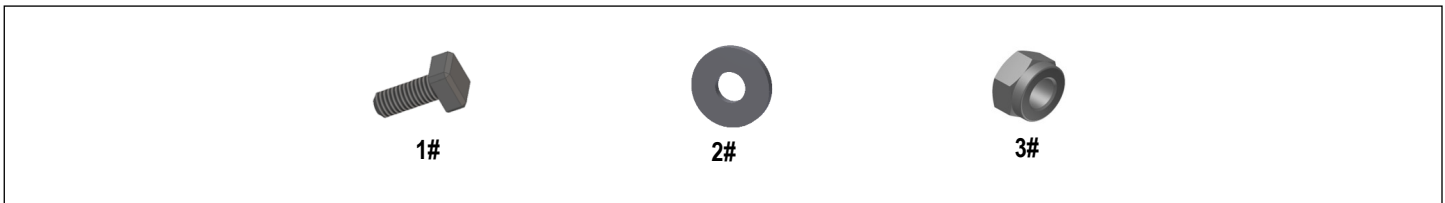



STEP 1

Start installation from the passenger side of the vehicle. Locate Passenger Side mounting locations. Remove any tape on the inside of rocker panel that covers the mounting holes. **NOTE:** (1) ST8x25mm Hex Self Tapping Screw replace (1) M8 bolt per bracket if the factory holes are not tapped for M8 bolts.

STEP 2

Attach the Passenger Side Mounting Brackets to the body panel as shown, (Fig 1). Do not fully tighten hardware at this time.

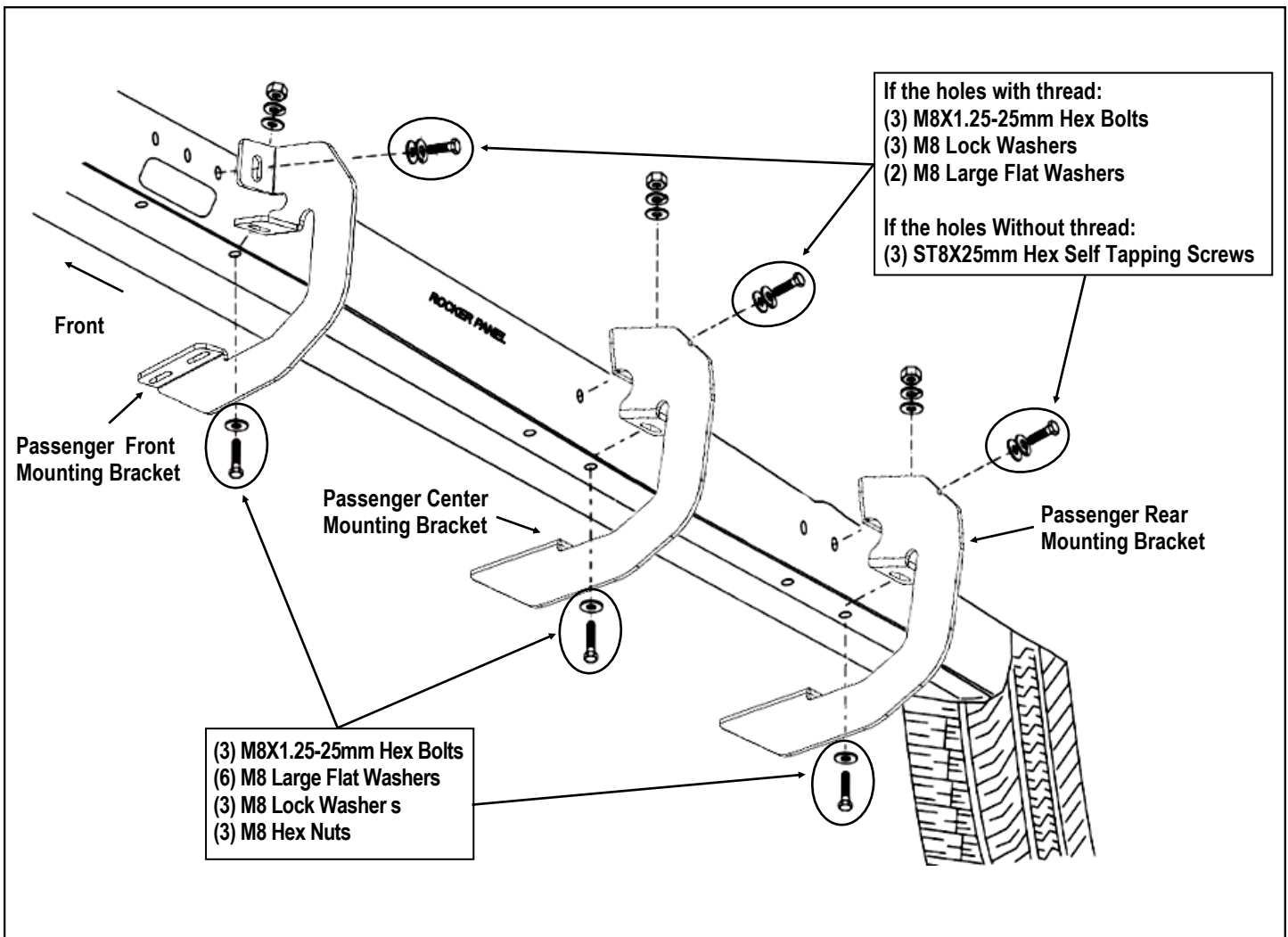

(Fig 1) Passenger Side Mounting Bracket Installation



STEP 3

Once all (3) mounting brackets are installed. Select a Running Board. Slip (3) M6X1-20mm Square Head Bolts into each bottom channel (**Fig 2**). Carefully position the Running Board onto the (3) Mounting Brackets. Attach the Running Board to each Mounting Brackets with (2) M6X1-20mm Square Head Bolts, (2) M6 Large Flat Washers and (2) M6X1 Nylon Lock Nuts (**Fig 3**). Do not fully tighten at this time.

IMPORTANT: Do not slide the Running Board on the Brackets or the bottom surface of the board will be damaged.

M6X1-20mm Square Head Bolts

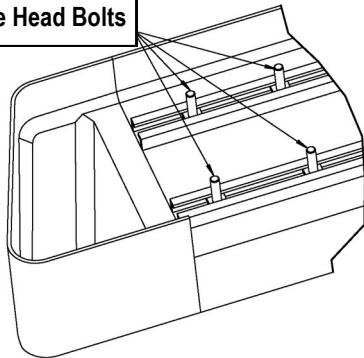

(Fig 2) Slip M6X1-20mm Square Head Bolts Into The Bottom Channels

(2) M6X1-20mm Square Head Bolts
(2) M6 Large Flat Washers
(2) M6X1 Nylon Lock Nuts

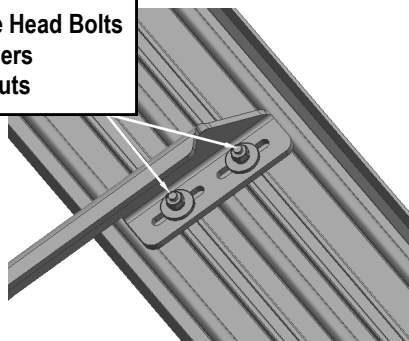

(Fig 3) Running Board Installed Onto Mounting Bracket

STEP 4

Level and adjust the Running Board and fully tighten all hardware.

Important: Please follow the recommended Tightening Torques shown in the table on page 1. Don't over tighten, or the nuts/bolts will be damaged.

STEP 5

Repeat **Steps 1-4** for the other side Running Board installation. The installation is completed .

Attention

Do periodic inspections to the installation to make sure that all hardware is secure and tight.

In order to protect your bars/boards, please use mild soap/non-abrasive products for cleaning only.