

# iBoard®



Scan for  
Installation Video

## iBoard® by APS

PART#: IB-P009Y&H

READ INSTRUCTIONS CAREFULLY BEFORE STARTING INSTALLATION. REMOVE CONTENTS FROM BOX AND VERIFY ALL PARTS ARE PRESENT. ASSISTANCE IS RECOMMENDED.

\*ROCKER PANEL MOUNT  
\*NO DRILLING REQUIRED

Fastener Size	Tightening Torque (ft-lbs)	Required
6mm	6-7	X
8mm	16-18	√
10mm	31-32	X
12mm	56-58	X
14mm	92-94	X

### PART LIST

#### Driver Side Step Bar



Front



#### Passenger Side Step Bar

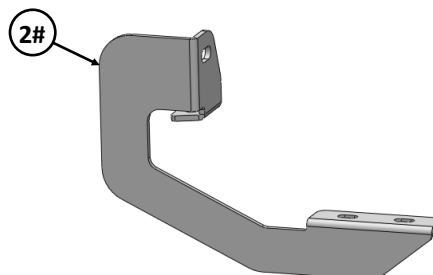
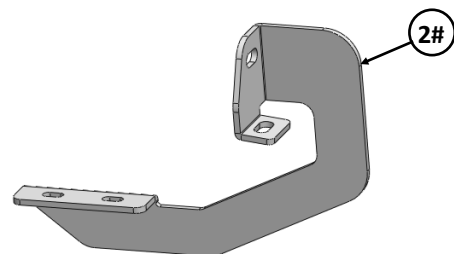
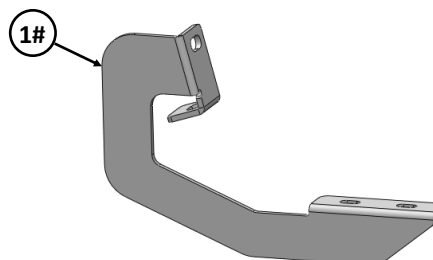
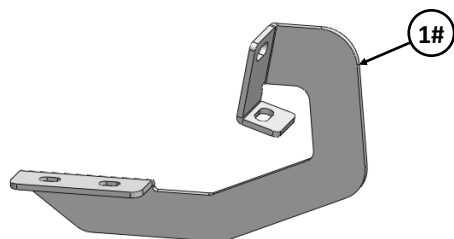





Customer Support: [info@iboardauto.com](mailto:info@iboardauto.com)



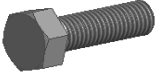



Hardware Package A (For Bracket Installation)					
Item	QTY	Description	Item	QTY	Description
1#	2	Driver / Passenger Front Mounting Brackets	5#	8	M8 Lock Washers
2#	2	Driver / Passenger Rear Mounting Brackets	6#	4	M8X1.25 Hex Nuts
3#	8	M8X1.25-30 Hex Bolts	7#	4	M8 Clip Nuts
4#	12	M8 Large Flat Washers			

				
3 #	4 #	5 #	6 #	7 #

Hardware Package B (For Step Bar Installation)					
Item	QTY	Description	Item	QTY	Description
1#	8	M8X1.25-35mm Carriage Bolts	3#	8	M8 Nylon Lock Nuts
2#	8	M8 Large Flat Washers	4#	4	Sliders (Packed with Mounting Brackets)

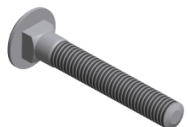
			
1 #	2 #	3 #	4 #

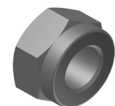

## STEP 1

Start installation under the Driver Side Front Mounting Location. Remove the large oval rubber cover located on the inner side panel toward the front, (Fig 1). Insert (1) M8 Clip Nut into the round hole (Fig 2). **NOTE:** Threaded nut must go towards the inside of the side panel.



(Fig 1) Driver Side Front Mounting Location

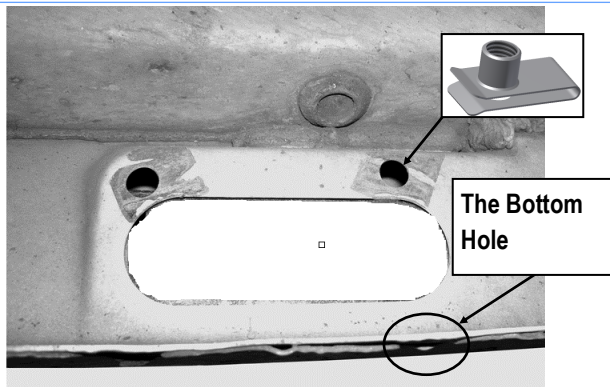

(Fig 2) Insert M8 Clip Nut into the Round Hole

## STEP 2

Select (1) Driver Front Mounting Bracket. Attach the Bracket to the installed M8 Clip Nut with the included (1) M8X1.25-30mm Hex Bolt, (1) M8 Lock Washer and (1) M8 Large Flat Washer, (Fig 3).

Align the bottom holes in the front Bracket with the (1) hole in the pinch weld (Fig 2). Bolt the Bracket to the pinch weld using the included (1) M8X1.25-30mm Hex Bolt, (2) M8 Large Flat Washers, (1) M8X1.25 Lock Washer and (1) M8 Hex Nut, (Fig 3).

**NOTE:** Insert the bolt up from the bottom of the pinch weld and through the Bracket.

- (1) M8 Clip Nut
- (1) M8X1.25-30mm Hex Bolt
- (1) M8 Lock Washer
- (1) M8 Large Flat Washer

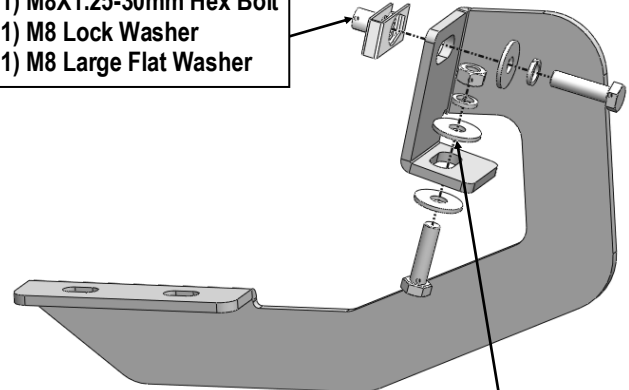

- (1) M8x1.25-25mm Hex Bolt
- (2) M8 Large Flat Washers
- (1) M8 Lock Washer
- (1) M8X1.25 Hex Nut

(Fig 3) Driver Front Mounting Bracket Installation

## STEP 3

Next, move along the vehicle to the Driver Side Rear Mounting Location, select a Driver Rear Mounting Bracket, repeat **Steps 1-2** to install the rear bracket (Fig 4). Do not fully tighten hardware at this time.

- (1) M8 Clip Nut
- (1) M8X1.25-30mm Hex Bolt
- (1) M8 Lock Washer
- (1) M8 Large Flat Washer

- (1) M8x1.25-25mm Hex Bolt
- (2) M8 Large Flat Washers
- (1) M8 Lock Washer
- (1) M8X1.25 Hex Nut

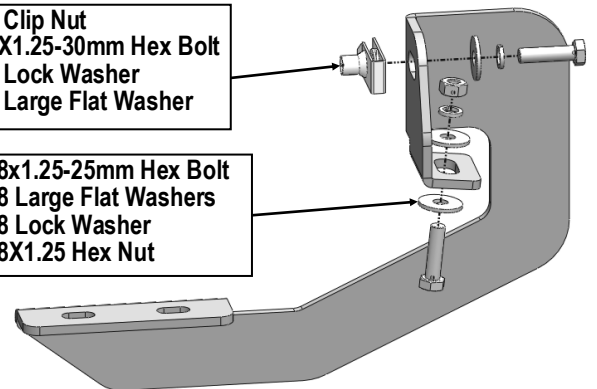

(Fig 4) Driver Rear Mounting Bracket Installation



## STEP 4

Once all (2) Driver side mounting brackets are installed, then proceed to the Step Bar installation. (Figs 5 & 6)

- (1) Select (1) Slider and (2) M8X1.25-35mm Carriage Bolts;
- (2) Install (2) M8X1.25-35mm Carriage Bolts in (1) Slider.
- (3) Slide the Slider (with carriage bolts) to the **Step Bar**.
- (4) Repeat to install the other (1) slider to the step bar.
- (5) Attach the Step Bar (with the Sliders) onto the installed mounting brackets. Position the Sliders to the installed brackets. Secure the Step Bar to the installed Brackets by using (4) M8 Large Flat Washers and (4) M8 Nylon Lock Nuts and (2) Sliders, (Fig 6). Do not fully tighten hardware at this time.

**Note:** The Sliders are packed with the Mounting Brackets.

Level and adjust the Step Bar and fully tighten all hardware.

Repeat **Steps 1-4** for the other side Step Bar installation. **The installation is completed!!!**

### Attention

**Do periodic inspections to the installation to make sure that all hardware is secure and tight.**

**In order to protect your bars/boards, please use mild soap/non-abrasive products for cleaning only.**

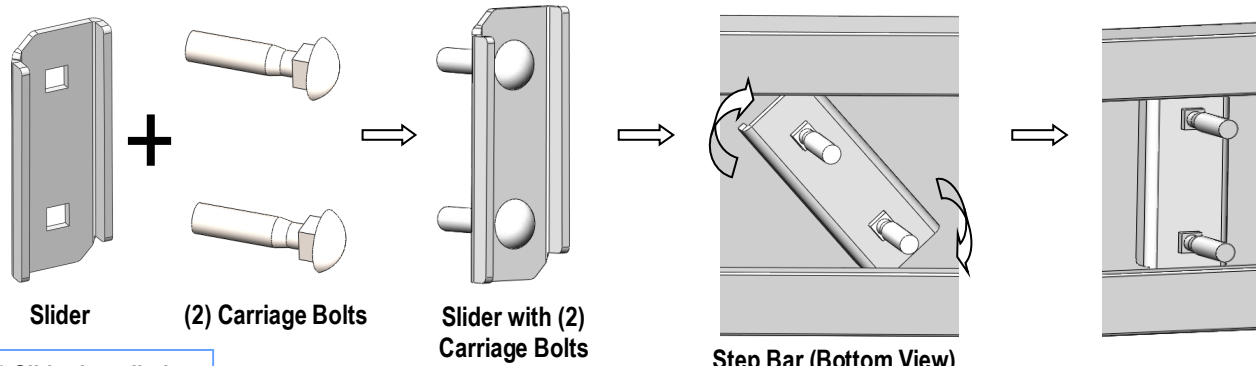

(Fig 5) Slider Installation

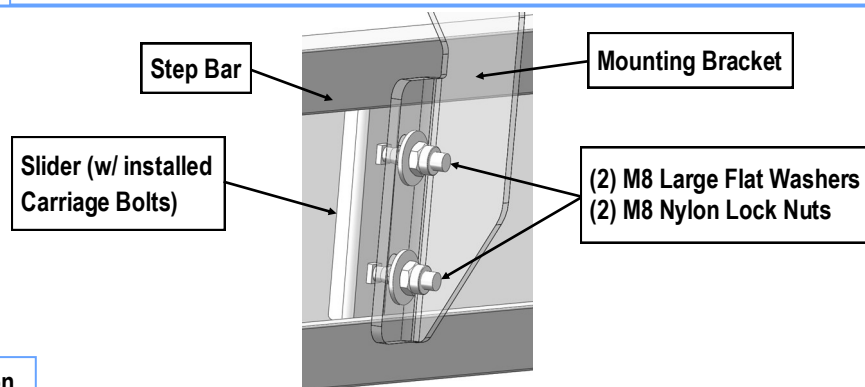

(Fig 6) Step Bar Installation