

iBoard®



Scan for
Installation Video

iBoard® by APS

PART#: IB-P034Y&H

READ INSTRUCTIONS CAREFULLY BEFORE STARTING INSTALLATION. REMOVE CONTENTS FROM BOX AND VERIFY ALL PARTS ARE PRESENT. ASSISTANCE IS RECOMMENDED.

*ROCKER PANEL MOUNT
*NO DRILLING REQUIRED

Fastener Size	Tightening Torque (ft-lbs)	Required
6mm	6-7	X
8mm	16-18	√
10mm	31-32	√
12mm	56-58	X
14mm	92-94	X

PART LIST

Driver Side Step Bar

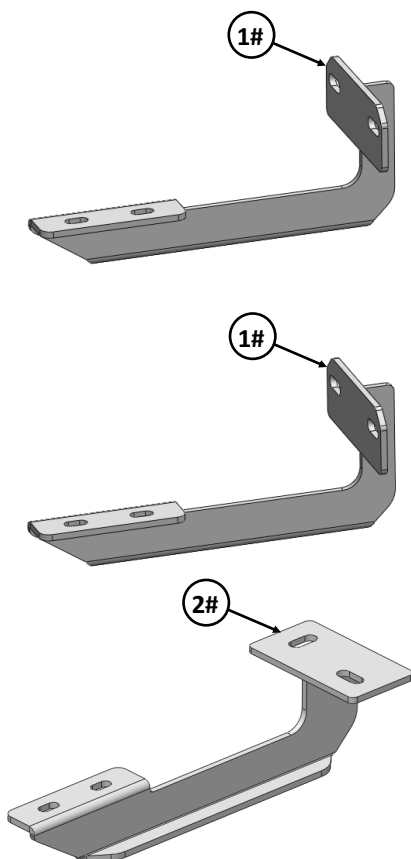

Front
↑

Passenger Side Step Bar

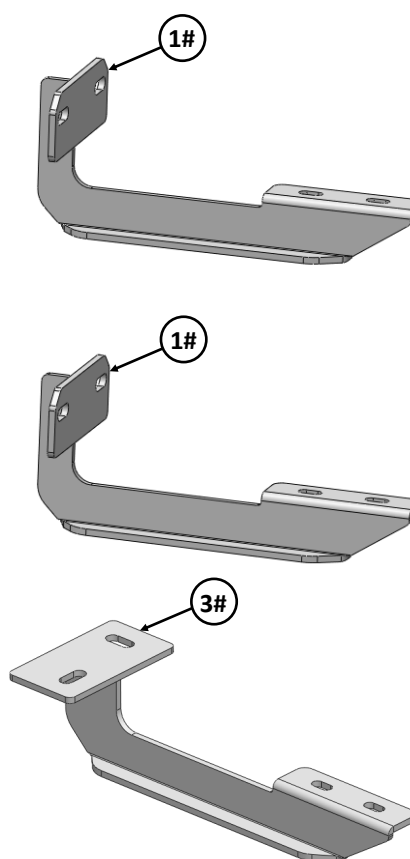

Customer Support: info@iboardauto.com



Scan for
Installation Video

Hardware Package A (For Bracket Installation)

Item	QTY	Description	Item	QTY	Description
1#	4	Driver / Passenger Front / Center Mounting Brackets	7#	4	M10 Large Flat Washers
2#	1	Driver Rear Mounting Bracket	8#	4	M10 Lock Washers
3#	1	Passenger Rear Mounting Bracket	9#	8	M8X1.25-35 Hex Bolts
4#	1	M10 Driver Double Nut Plate	10#	8	M8 Large Flat Washers
5#	1	M10 Passenger Double Nut Plate	11#	8	M8 Lock Washers
6#	4	M10X1.5-40 Hex Bolts			



4 #



5 #



6 #



7 #



8 #



9 #



10 #



11 #

Hardware Package B (For Step Bar Installation)

Item	QTY	Description	Item	QTY	Description
1#	12	M8X1.25-35mm Carriage Bolts	3#	12	M8 Nylon Lock Nuts
2#	12	M8 Large Flat Washers	4#	6	Sliders (Packed with Mounting Brackets)

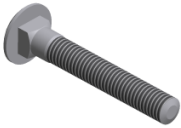

1 #



2 #

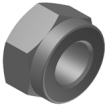

3 #



4 #



STEP 1

Start installation from the driver side front of the vehicle. Locate the (2) factory 8mm threaded holes in the inner body panel.

NOTE: Holes may be covered with plugs or under-coating, remove if equipped.

Select (1) Mounting Bracket. Bolt the Mounting Bracket to the (2) threaded holes with (2) M8X1.25-35mm Hex Bolts, (2) M8 Lock washers and (2) M8 Large Flat Washers. Do not fully tighten hardware at this time.

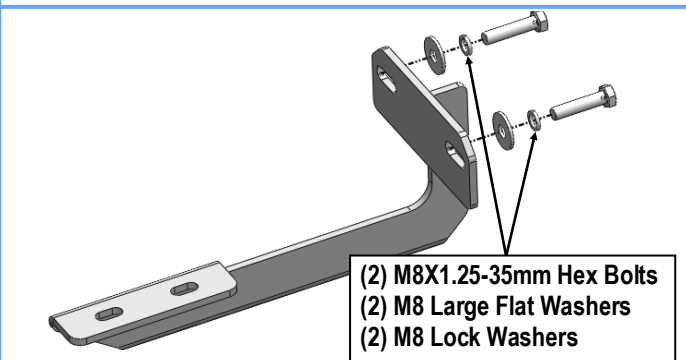

(Fig 1) Driver Side Front Mounting Bracket Installation

STEP 2

Move to the center location. Repeat **Step 1** for driver side Center Bracket installation. Do not fully tighten hardware at this time. **NOTE: Driver / Passenger side front and center Bracket are universal.**

STEP 3

Move to the driver side rear of the vehicle. Locate the oval and round hole in bottom of the floor panel. Insert (1) M10 Driver Double Nut Plate into the oval hole. Line up the threaded nuts with the round and oval holes, (Fig 2). **NOTE:** Nut Plate must be flat against the inside of the body panel with the Welded nuts on top.

Select the Driver Rear Mounting Bracket. Bolt the Bracket to the M10 Driver Double Nut Plate with (2) M10X1.5-40mm Hex Bolts, (2) M10 Lock Washers and (2) M10 Large Flat Washers, (Fig 2). Do not fully tighten hardware at this time.

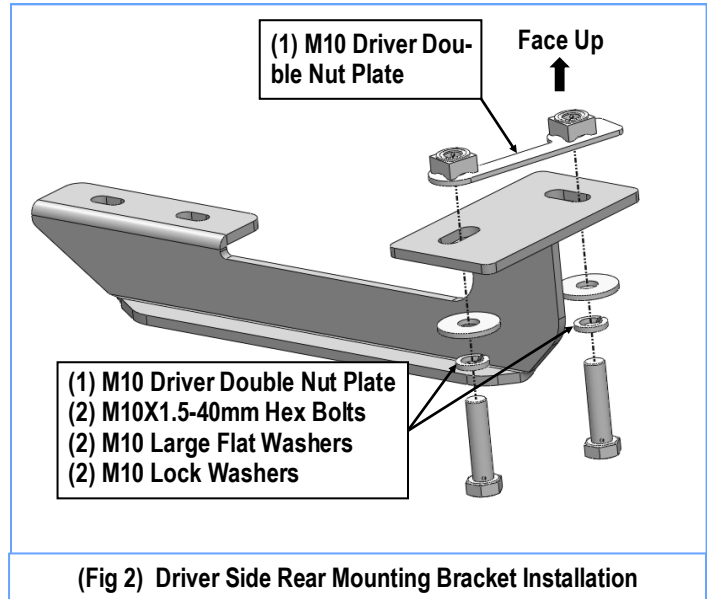

(Fig 2) Driver Side Rear Mounting Bracket Installation

STEP 4

Once all (3) Driver side mounting brackets are assembled, then proceed to the Step Bar installation. (Figs 3&4)

(1) Select (1) Slider and (2) M8X1.25-35mm Carriage Bolts;

(2) Install (2) M8X1.25-35mm Carriage Bolts in (1) Slider.

(3) Slide the Slider (with carriage bolts) to the **Step Bar**.

(4) Repeat to install the other (2) sliders to the step bar.

(5) Attach the Step Bar (with the Sliders) onto the installed mounting brackets. Position the Sliders to the installed brackets. Secure the Step Bar to the installed Brackets by using (6) M8 Large Flat Washers and (6) M8 Nylon Lock Nuts and (3) Sliders, (Fig 4). Do not fully tighten hardware at this time.

Note: The Sliders are packed with the Mounting Brackets.

Level and adjust the Step Bar and fully tighten all hardware.

Repeat **Steps 1-4** for the other side Step Bar installation. **The installation is completed!!!**

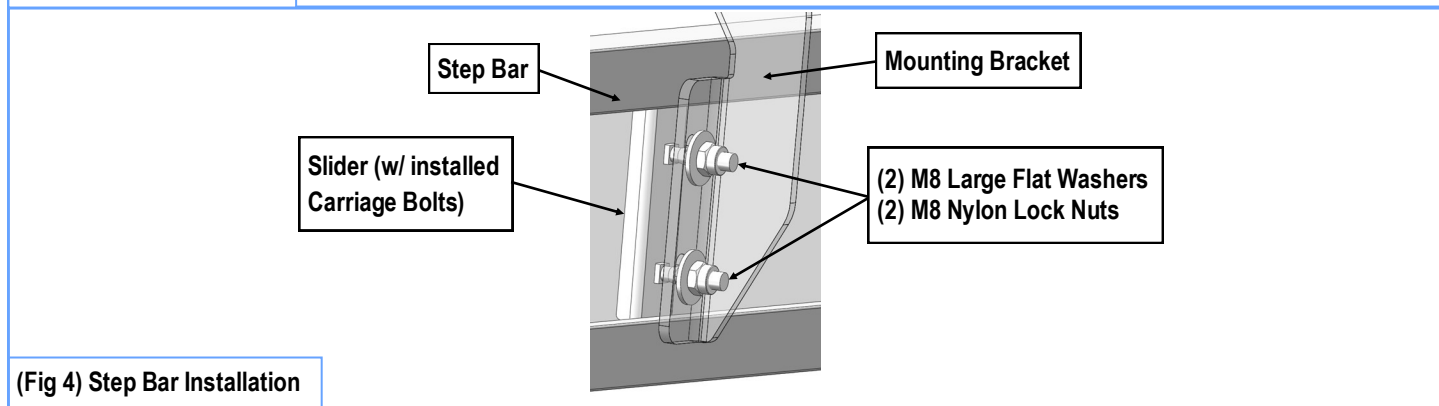
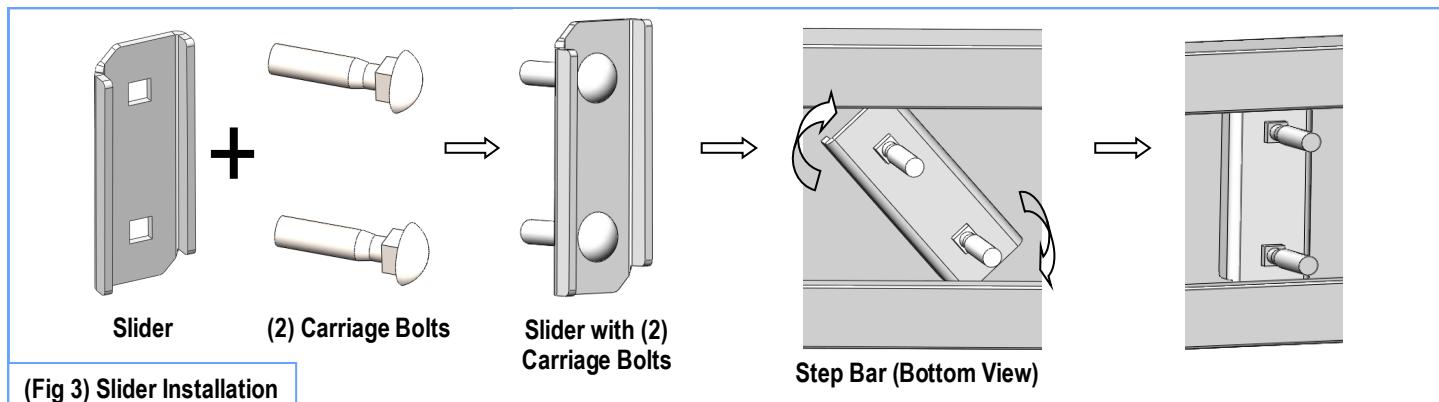

Attention

Do periodic inspections to the installation to make sure that all hardware is secure and tight.
In order to protect your bars/boards, please use mild soap/non-abrasive products for cleaning only.