



## iBoard® by APS

PART#: IB-P310Y&H

READ INSTRUCTIONS CAREFULLY BEFORE STARTING INSTALLATION. REMOVE CONTENTS FROM BOX AND VERIFY ALL PARTS ARE PRESENT. ASSISTANCE IS RECOMMENDED.

\*ROCKER PANEL MOUNT  
\*NO DRILLING REQUIRED

Fastener Size	Tightening Torque (ft-lbs)	Required
6mm	6-7	X
8mm	16-18	√
10mm	31-32	√
12mm	56-58	X
14mm	92-94	X

### PART LIST

#### Driver Side Step Bar

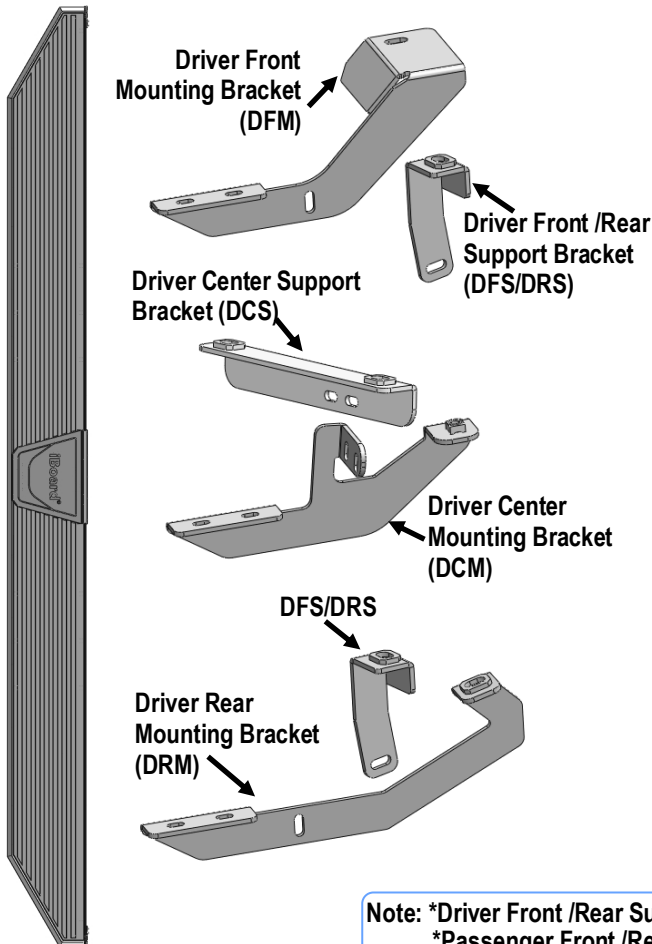

Front



#### Passenger Side Step Bar

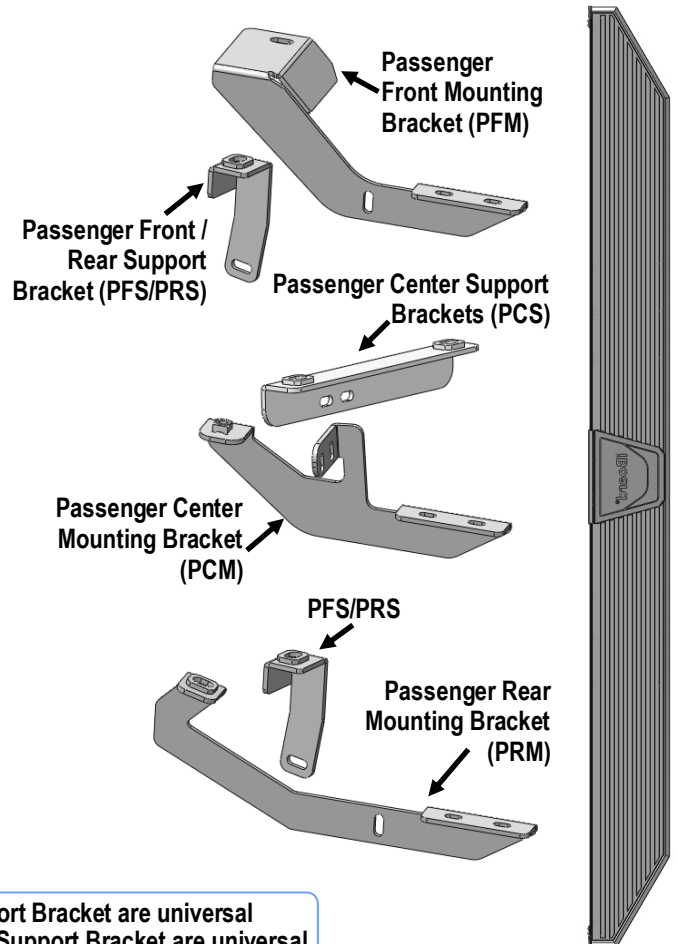

Note: \*Driver Front /Rear Support Bracket are universal  
\*Passenger Front /Rear Support Bracket are universal



## Hardware Package A (For Bracket Installation)

Item	QTY	Description	Item	QTY	Description
1#	2	Support Plates	8#	14	M10 Lock Washers
2#	2	M10X35 Bolt Plates	9#	14	M10X1.5 Hex Nuts
3#	2	M10X40 Bolt Plates	10#	8	M8X1.25-25mm Hex Bolts
4#	4	M10 Plastic Washers	11#	16	M8 Large Flat Washers
5#	8	M10 J-Bolts	12#	8	M8 Lock Washers
6#	2	M10X1.5-60mm Hex Bolts	13#	8	M8X1.25 Hex Nuts
7#	14	M10 Large Flat Washers			



## Hardware Package B (For Step Bar Installation)

Item	QTY	Description	Item	QTY	Description
1#	12	M8X1.25-35mm Carriage Bolts	3#	12	M8 Nylon Lock Nuts
2#	12	M8 Large Flat Washers	4#	6	Sliders (Packed with Mounting Brackets)

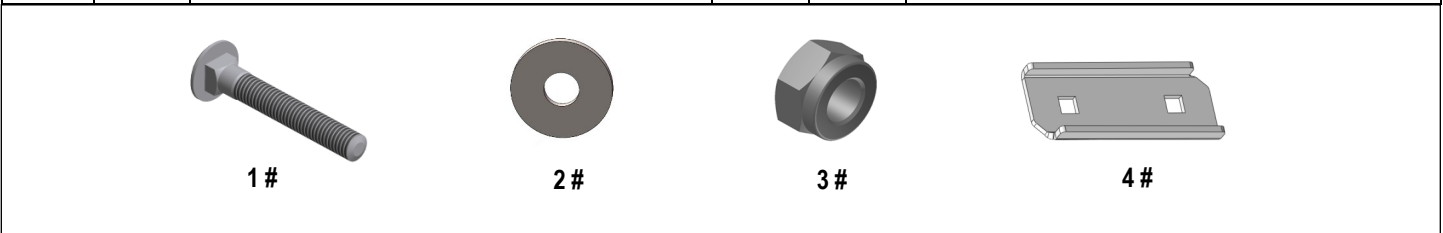



## STEP 1

Start the installation from Driver Side Mounting Locations of the vehicle, remove the large plastic cover on the bottom of the floor panel, (**Fig 1**). Determine which plastic clips need to be removed. Carefully remove only the plastic clips for installation.

Remove plastic trim clips

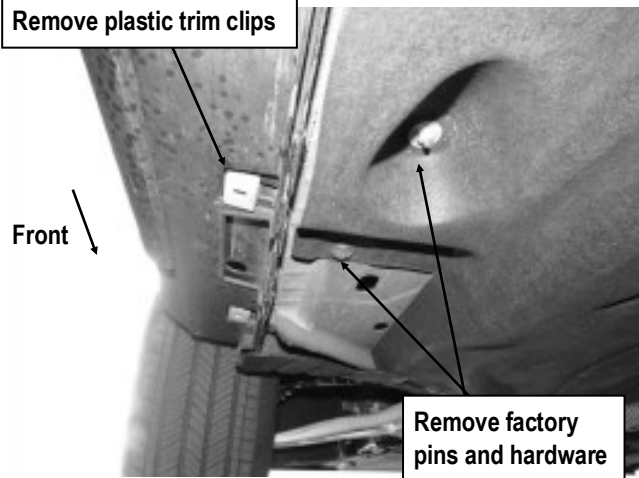

(Fig 1) Driver Side Front Mounting Location

## STEP 2

Locate the Driver Side Front Mounting Location, (**Fig 2**). Insert (1) M10X35 Bolt Plate into the slot on the floor panel, (**Fig 2**). Thread (1) M10 Plastic Washer onto the Bolt Plate to hold it in place within the bracket installation. Select (1) M10 J-Bolt, insert the tail of J-Bolt all the way up into the round hole on the side panel. Rotate and pull the J-Bolt outwards, keep the thread pointing to the ground, (**Fig 3**).

**NOTE:** Scan the QR code or follow link for M10 J-Bolt installation video.



<https://youtu.be/BqQis3QjZNc>

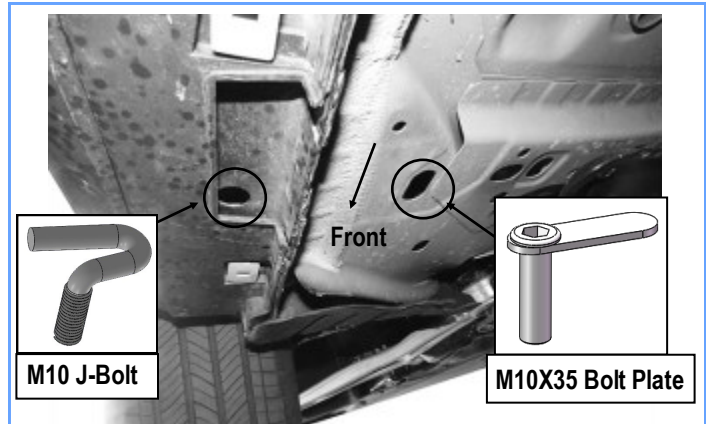

(Fig 2) Driver Side Front Mounting Location



(Fig 3) M10 J-Bolt Installation  
(On Driver Side Mounting Location)



## STEP 3

Select the Driver Front Mounting Bracket (**DFM**) and the Driver Front Support Bracket (**DFS/DRS**), assemble with (1) M8X1.25-25mm Hex Bolt, (2) M8 Large Flat Washers, (1) M8 Lock Washer and (1) M8X1.25 Hex Nut, (**Fig 4**). Do not fully tighten at this time.

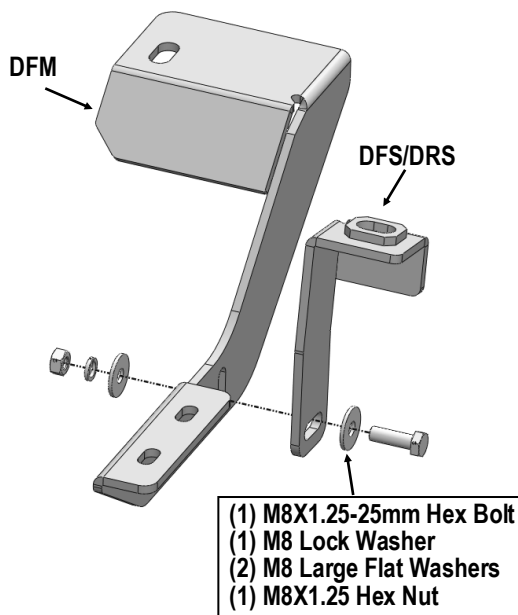

(Fig 4) Driver Side Front Brackets Assembly

## STEP 4

Attach the assembled Mounting Bracket to the installed M10X35 Bolt Plate with (1) M10 Large Flat Washer, (1) M10 Lock Washer and (1) M10X1.5 Hex Nut.

Secure the Drive Front Support Bracket (**DFS/DRS**) to the installed M10 J-Bolt with (1) M10 Large Flat Washer, (1) M10 Lock Washer and (1) M10X1.5 Hex Nut, (**Fig 5**).

Do not fully tighten at this time.

- (1) M10 J-Bolt
- (1) M10 Large Flat Washer
- (1) M10 Lock Washer
- (1) M10X1.5 Hex Nut

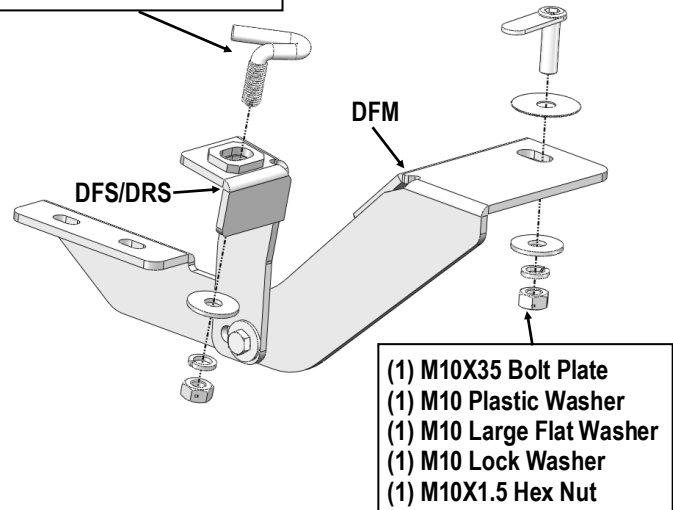

(Fig 5) Driver Side Front Mounting Bracket Installation

## STEP 5

Select the Driver Center Mounting Bracket (**DCM**) and the Driver Center Support Bracket (**DCS**), assemble with (2) M8X1.25-25mm Hex Bolts, (4) M8 Large Flat Washers, (2) M8 Lock Washers and (2) M8X1.25 Hex Nuts, (**Fig 6**). Do not fully tighten at this time.

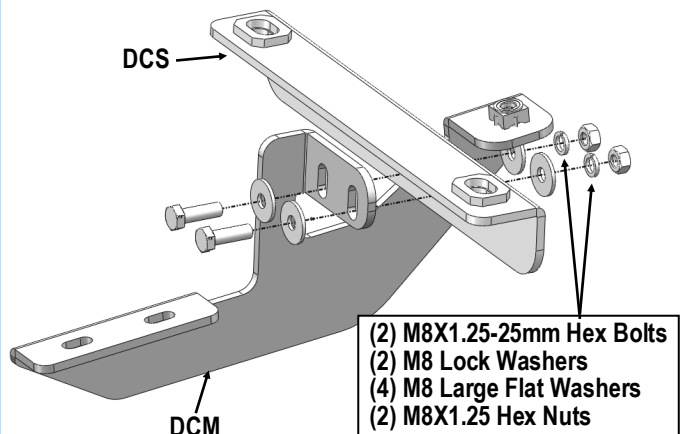

(Fig 6) Driver Side Center Brackets Assembly



## STEP 6

Move to the Driver Side Center Mounting Location, (Fig 7). Insert (2) M10 J-Bolts into the side panel, (Fig 8). Attach the Driver Center Support Bracket (DCS) to the installed (2) M10 J-Bolts with (2) M10 Large Flat Washers, (2) M10 Lock Washers and (2) M10X1.5 Hex Nuts, (Fig 9). Do not fully tighten at this time.

Select and install (1) Support Plate (Fig 9):

- Thread (1) M10X1.5 Hex Nut to (1) M10X1.5-60mm Hex Bolt. Slide (1) M10 Lock Washer and (1) M10 Flat washer onto the M10X1.5-60mm Hex Bolt. (NOTE: Use the M10X1.5 Hex Nut to adjust the level of the Mounting Bracket.)
- Thread the M10X1.5-60mm Hex Bolt assembly into the welded nut on the back of the Mounting Bracket. Place the Support Plate onto the end of the M10 Hex Bolt, (Fig 9).
- Tighten Hex Bolt to attach the Support Plate onto the floor panel. Do not tighten Hex Bolt all the way.

**NOTE:** Scan the QR code or follow link for Support Plate installation.



<https://www.youtube.com/watch?v=R51s7Vk1Sy4>

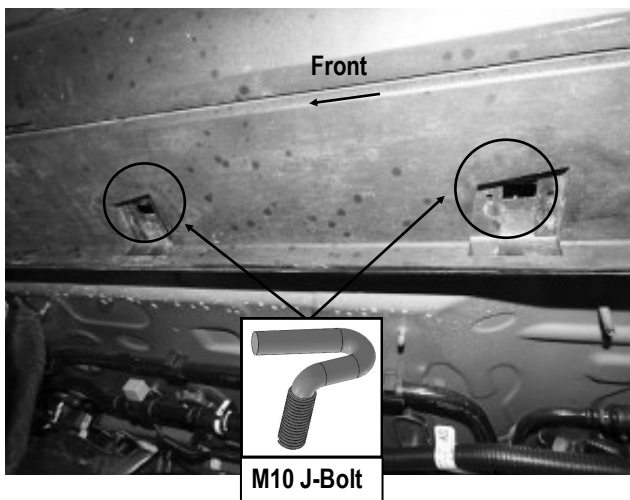

(Fig 7) Driver Side Center Mounting Location

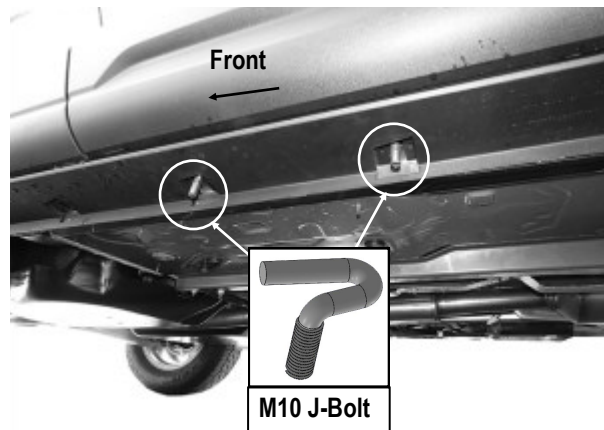

(Fig 8) M10 J-Bolts Installation  
(On Driver Side Center Mounting Location)

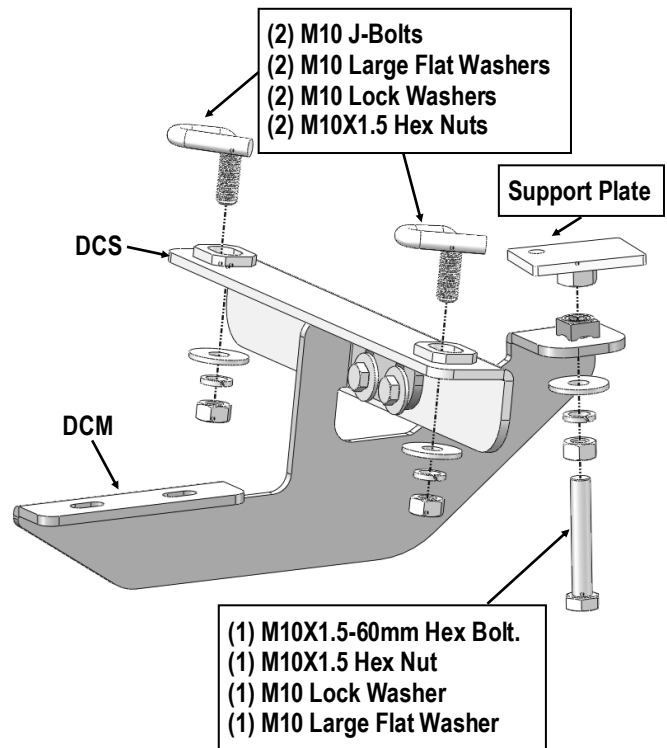

(Fig 9) Driver Side Center Brackets Installation

## STEP 7

Move to the Driver Side Rear Mounting Location, (Fig 10). Repeat **Steps 2- 4** to attach the Driver Rear Mounting Brackets, (Figs 10—13). Do not fully tighten hardware.



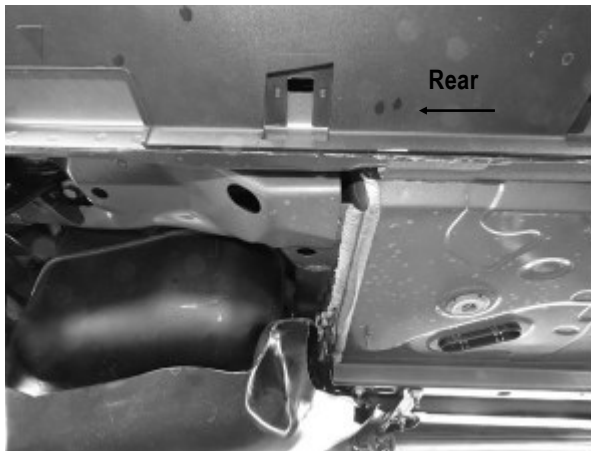

(Fig 10) Driver Side Rear Mounting Location

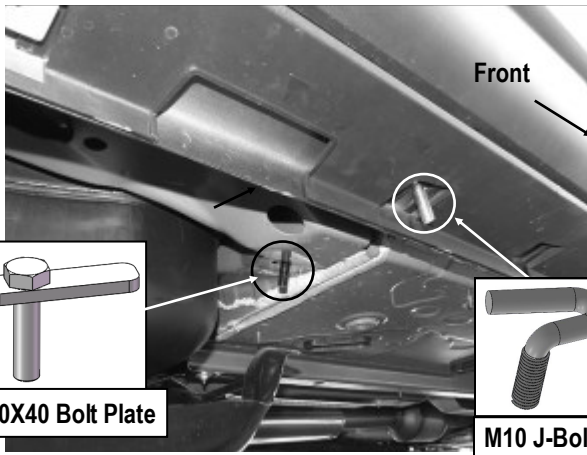

(Fig 11) Insert (1) M10 J-Bolt And (1) M10X40 Bolt Plate

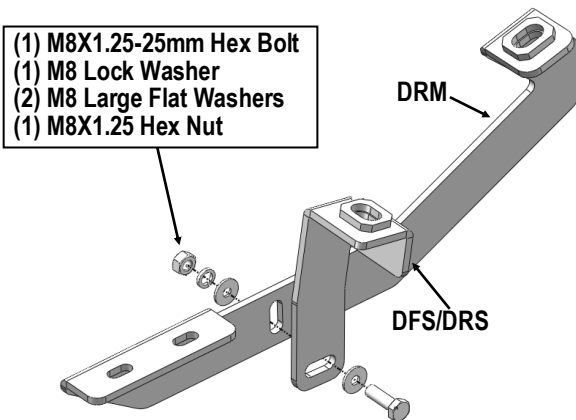

(Fig 12) Driver Side Rear Brackets Assembly

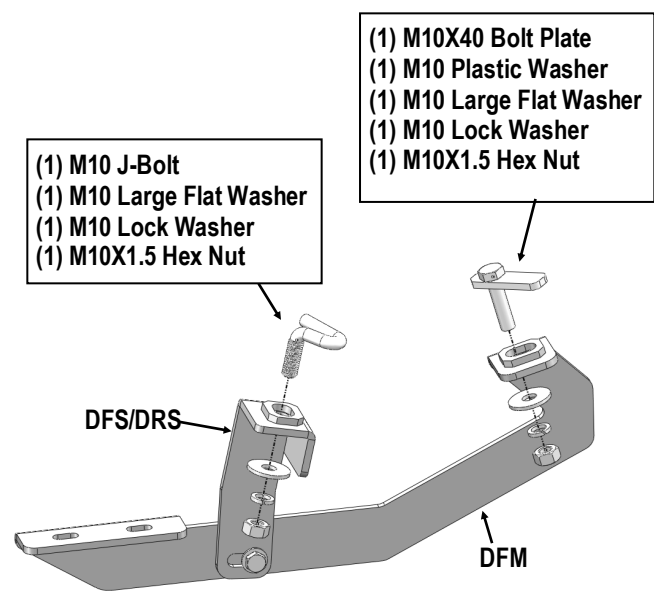

(Fig 13) Driver Side Rear Mounting Bracket Installation

## STEP 8

Once all (3) Passenger side mounting brackets are installed, then proceed to the Step Bar installation. (Figs 14 & 15)

- (1) Select (1) Slider and (2) M8X1.25-35mm Carriage Bolts;
- (2) Install (2) M8X1.25-35mm Carriage Bolts in (1) Slider.
- (3) Slide the Slider (with carriage bolts) to the **Step Bar**.
- (4) Repeat to install the other (2) sliders to the step bar.
- (5) Attach the Step Bar (with the Sliders) onto the installed mounting brackets. Position the Sliders to the installed brackets. Secure the Step Bar to the installed Brackets by using (6) M8 Large Flat Washers and (6) M8 Nylon Lock Nuts and (3) Sliders, (Fig 15). Do not fully tighten hardware at this time.

**Note:** The Sliders are packed with the Mounting Brackets.

Level and adjust the Step Bar and fully tighten all hardware.

Repeat **Steps 1-8** for the other side Step Bar installation. **The installation is completed!!!**

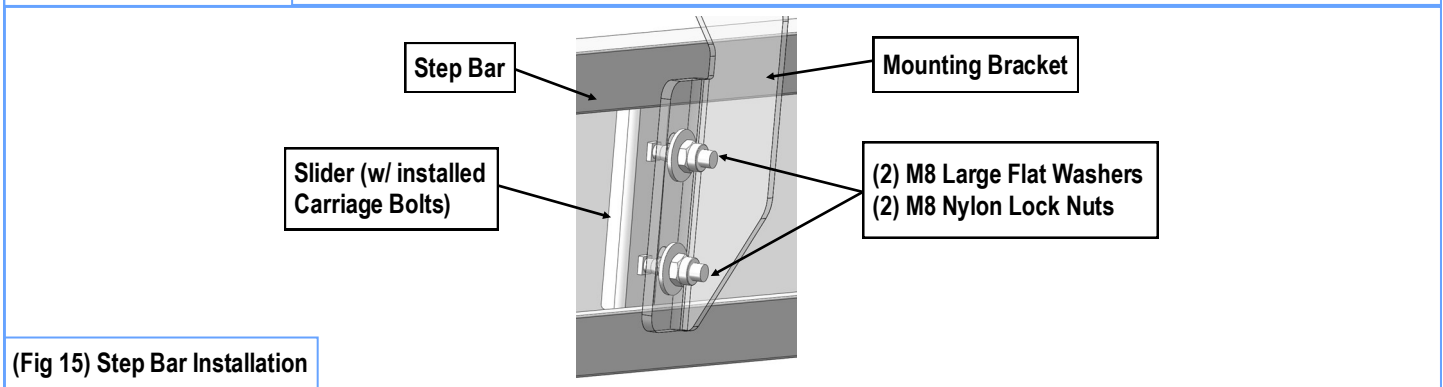
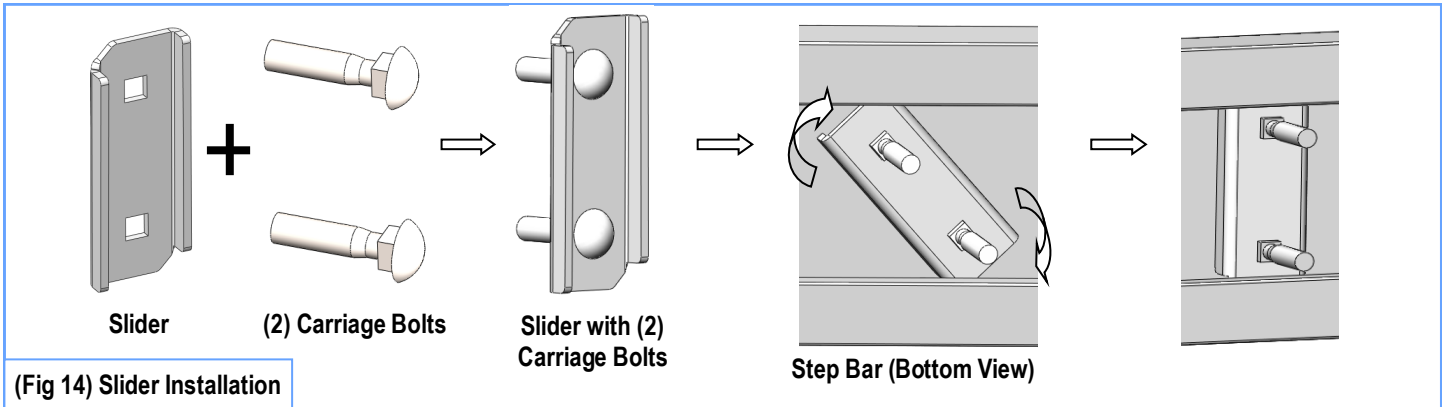

### Attention

Do periodic inspections to the installation to make sure that all hardware is secure and tight.  
In order to protect your bars/boards, please use mild soap/non-abrasive products for cleaning only.