

iBoard®



Scan for
Installation Video

iBoard® by APS

PART#: IB-P136Y&H

READ INSTRUCTIONS CAREFULLY BEFORE STARTING INSTALLATION. REMOVE CONTENTS FROM BOX AND VERIFY ALL PARTS ARE PRESENT. ASSISTANCE IS RECOMMENDED.

*ROCKER PANEL MOUNT
*DRILLING IS REQUIRED

Fastener Size	Tightening Torque (ft-lbs)	Required
6mm	6-7	X
8mm	16-18	√
10mm	31-32	√
12mm	56-58	X
14mm	92-94	X

PART LIST

Driver Side Step Bar



Driver Front Support
Bracket (DFS)

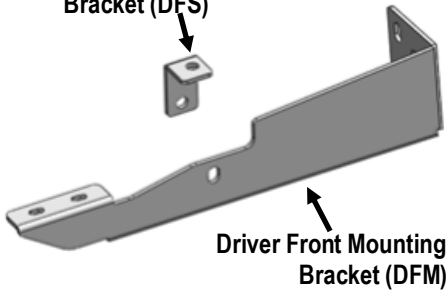

Driver Front Mounting
Bracket (DFM)

Driver Rear Mounting
Bracket (DRM)

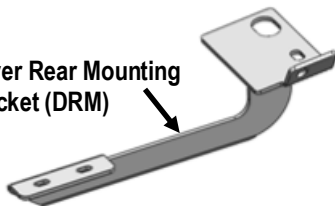

Front
↑

Passenger Side Step Bar



Passenger Front Support
Bracket (PFS)

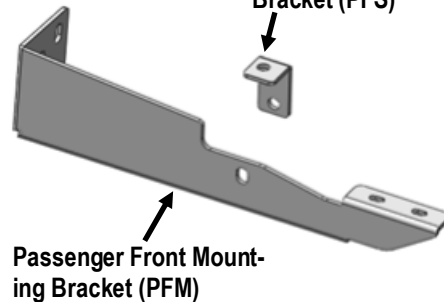

Passenger Front Mounting
Bracket (PFM)

Passenger Rear Mounting
Bracket (PRM)

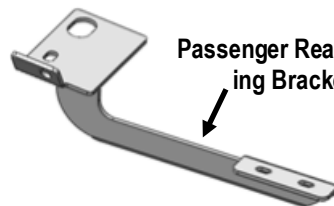

Customer Support: info@iboardauto.com



Hardware Package A (For Bucket Installation)					
Item	QTY	Description	Item	QTY	Description
1#	2	M10X1.5 Double Nut Plates	7#	6	M10 Lock Washers
2#	2	M10X35mm Bolt Plates	8#	2	M10X1.5 Hex Nuts
3#	4	M10X1.5-45mm Hex Bolts	9#	2	M10X1.5 Nylon Lock Nuts
4#	2	M10X1.5-30mm Hex Bolts	10#	2	M8X1.25-25mm Hex Bolts
5#	4	M10 Large Flat Washers	11#	4	M8 Large Flat Washers
6#	6	M10 Flat Washer	12#	2	M8 Lock Washers

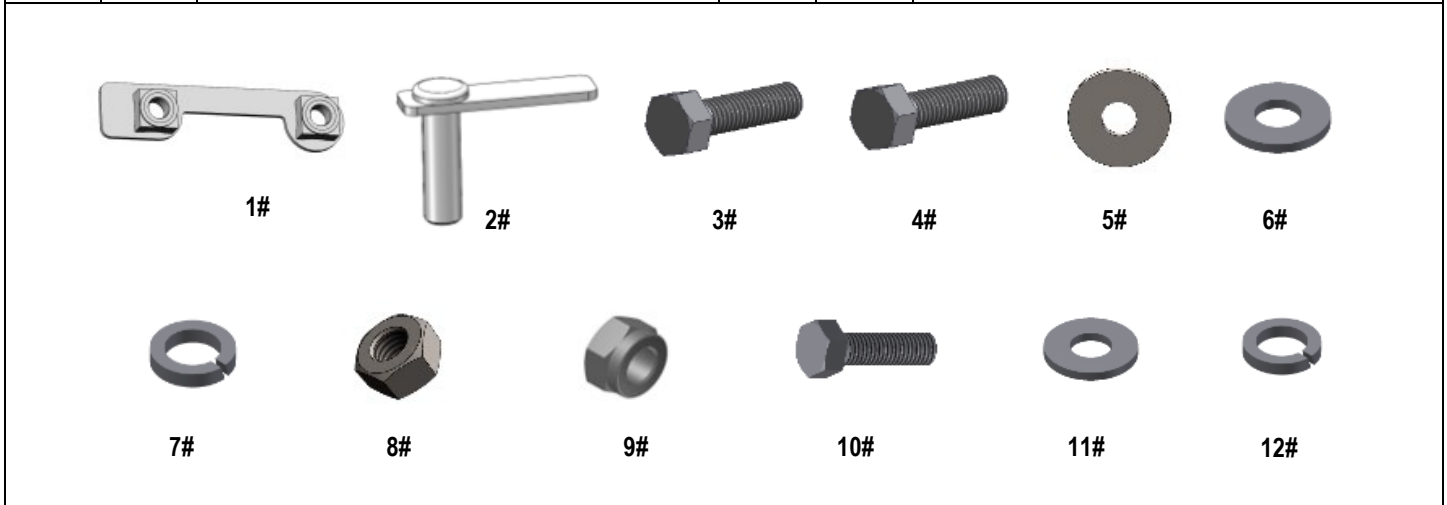

Hardware Package B (For Step Bar Installation)					
Item	QTY	Description	Item	QTY	Description
1#	8	M8X1.25-35mm Carriage Bolts	3#	8	M8 Nylon Lock Nuts
2#	8	M8 Large Flat Washers	4#	4	Sliders (Packed with Mounting Brackets)

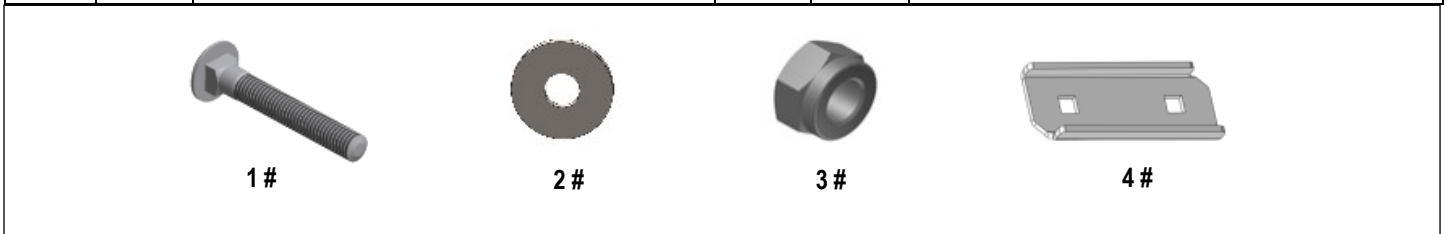



STEP 1

Start installation from the driver side of the vehicle. Remove the screw on the front fender (**Fig 1**). Next, remove the (3) plastic clips from the plastic rocker trim panel. And then, gently pull the plastic trim panel outside gently to locate the factory hole on the body panel, (**Fig 2**).

NOTE: It will be helpful for identifying the mounting holes to hold up the Front mounting bracket in place.



(Fig 1) Remove Screw from the front fender

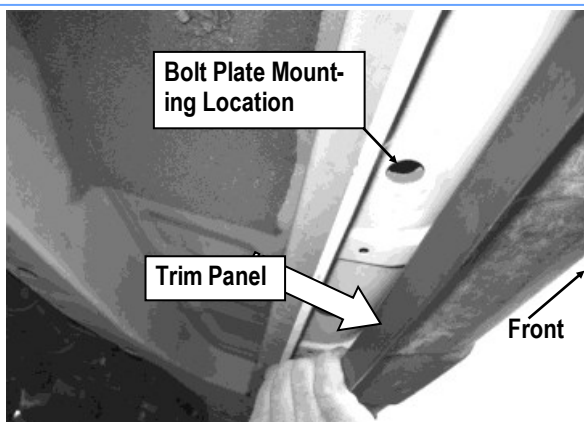

(Fig 2) Driver Side Front Mounting Location
(Remove 3 Plastic Clips and pull out the trim panel)

STEP 2

Mark the position of the factory hole onto the plastic trim panel. Drill through hole on the plastic panel carefully by using a 7/16" drill bit (**Fig 3 & 4**).

IMPORTANT: Only drill through the plastic panel. Take precautions to avoid damage to the vehicle.

Gently pull the cover aside to insert (1) M10X35mm Bolt Plate into the factory hole in the body panel, (**Fig 3**). Once the Bolt Plate is in place, reposition the plastic rocker panel over the Bolt Plate and into the original position, (**Fig 4**). Secure with factory clips and metal screw.

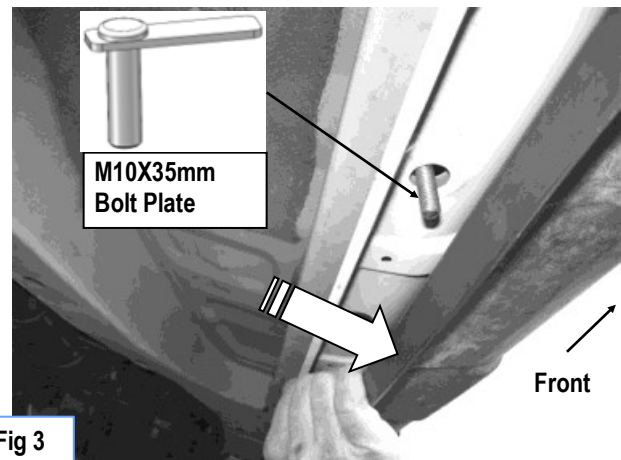

Fig 3

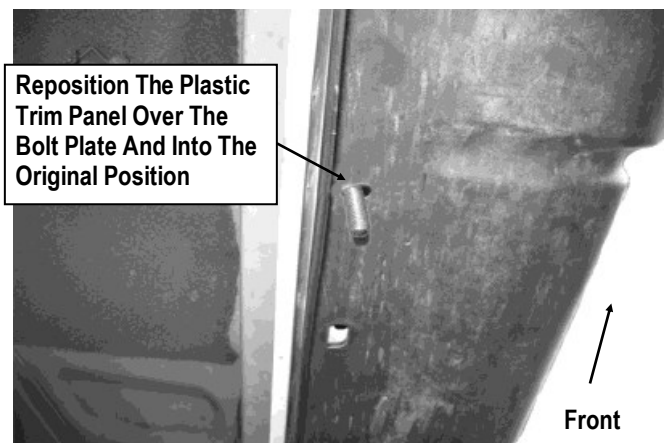
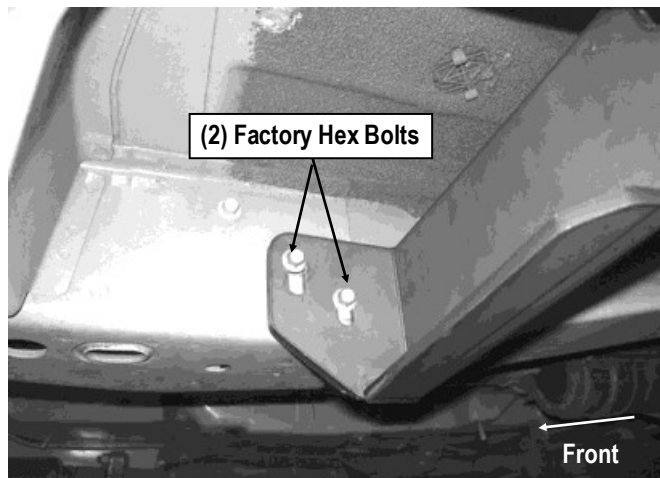

Fig 4



STEP 3

Locate the (3) factory bolts on the side of the frame rail. Remove the (2) lower bolts only. Position the Driver Front Mounting Bracket (DFM) up to the frame rail. Line up the holes in the Mounting Bracket with (2) threaded holes. Secure the Mounting Bracket with the (2) factory bolts, (Fig 5). Do not fully tighten at this time.



(Fig 5) Driver Front Mounting Bracket (DFM) Installed

STEP 4

Place the Driver Front Support Bracket (DFS) onto the installed M10 Bolt Plate using (1) M10 Flat Washer, (1) M10 Lock Washer and (1) M10X1.5 Hex Nut.

Attach the opposite end of the Driver Front Support Bracket to the back of the Driver Front Mounting Bracket with (1) M10X1.5-40mm Hex Bolt, (2) M10 Flat Washers and (1) M10X1.5 Nylon Lock Nut, (Fig 6 & 7). Do not fully tighten hardware at this time.

NOTE: Shorter tab on the Support Bracket mounts to the rocker panel, longer end to the Mounting Bracket.

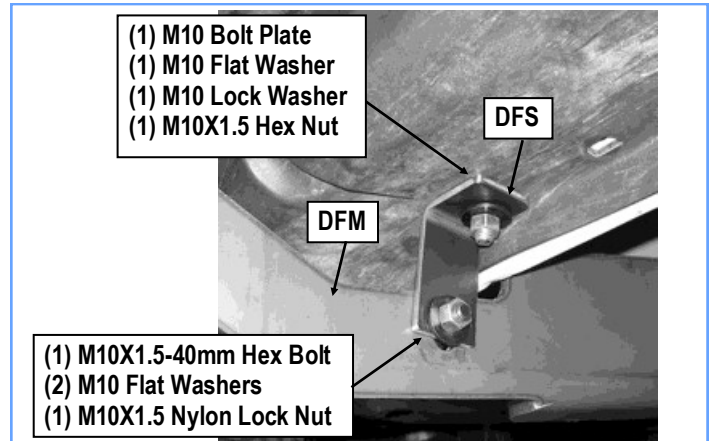

(Fig 6) Driver Front Support Bracket (DFS) Installed

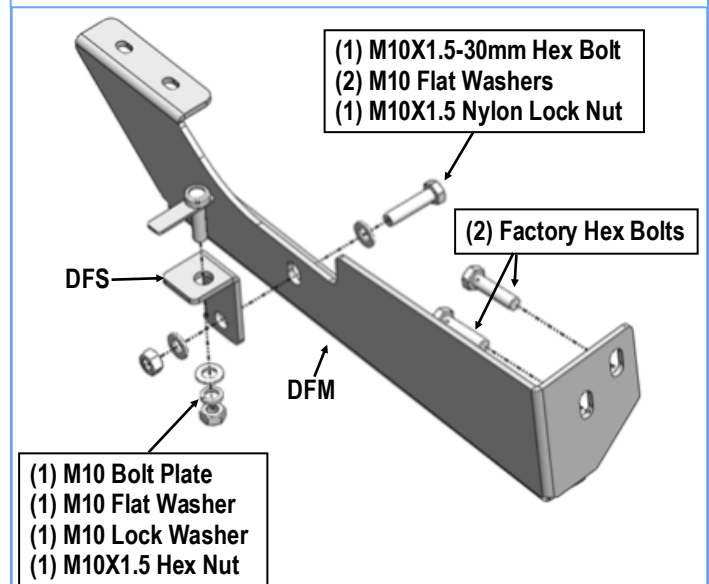

(Fig 7) Driver Front Mounting Bracket Installation

STEP 5

Moving to the driver side rear of the vehicle, locate the (3) holes on the floor panel next to the pinch weld. Remove the factory rubber plug if equipped, (08 Escape only), facing the rear of the vehicle, (Fig 8).

Insert (1) M10X1.5 Double Nut Plate through the large round hole and line up the threaded nuts on the M10X1.5 Double Nut Plate with the smaller round and oval holes, (Fig 9).

NOTE: Nut Plate must be flat against the inside of the body panel with the Welded Nuts on top.

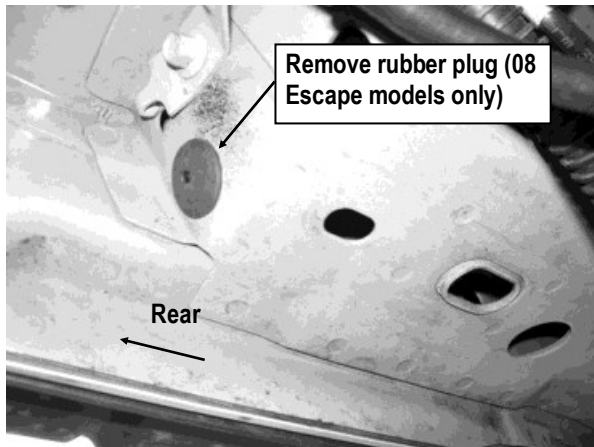

(Fig 8) Driver Side Rear Mounting Location

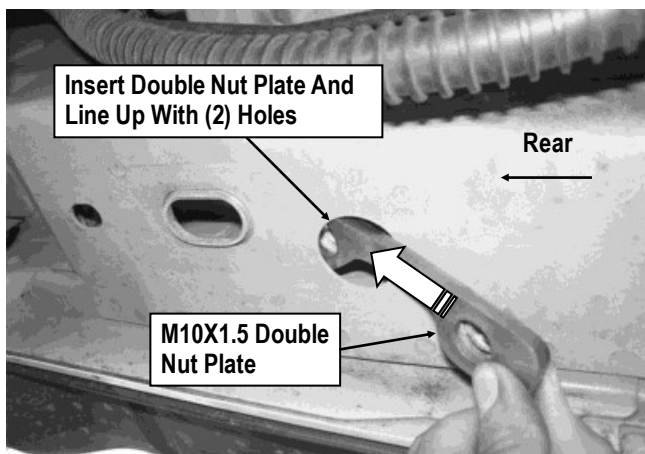

(Fig 9) M10X1.5 Double Nut Plate Installation

STEP 6

Driver Rear Mounting Bracket Installation:

For 09-12 Escape and other Models:

Attach the Driver Rear Mounting Bracket (DRM) onto the installed M10X1.5 Double Nut Plate with (2) M10X1.5-45mm Hex Bolts, (2) M10 Large Flat Washers and (2) M10 Lock Washers (Fig 10).

For 08 Escape Only:

Secure Mounting Bracket to threaded hole with (1) M8X1.25-25mm Hex Bolt, (1) M8 Large Flat Washer, and (1) M8 Lock Washer, (Fig 10).

Passenger Rear Mounting Bracket Installation:

For 08 Escape Only:

Repeat the Step 6 to install the Passenger Rear Mounting Bracket.

For: 09-12 Escape and other models:

The Passenger Rear Mounting Bracket (PRM) will be installed between the factory exhaust supporter and the body panel. Remove the (2) M8 Hex Bolts securing the bracket, move the exhaust support slightly. And repeat **Step 6** to install the passenger side Mounting Bracket, (Fig 11).

Reinstall the exhaust supporter using the factory hex bolts and insert (1) M8 Large Flat Washer, and (1) M8 Lock Washer, between the exhaust supporter and the Mounting Bracket. On the remaining top location, insert (2) M8 Flat Washers between the body panel and the exhaust supporter to evenly space the support from the body panel.

Driver side 08 Escape Only:

- (1) M8X1.25-25mm Hex Bolt
- (1) M8 Large Flat Washer
- (1) M8 Lock Washer

- (1) M10 Double Nut Plate
- (2) M10X1.5-45mm Hex Bolts
- (2) M10 Large Flat Washers
- (2) M10 Lock Washers

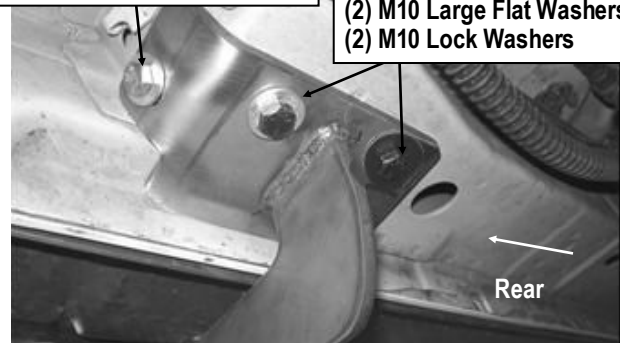

(Fig 10) Driver Rear Mounting Bracket (DRM) Installed

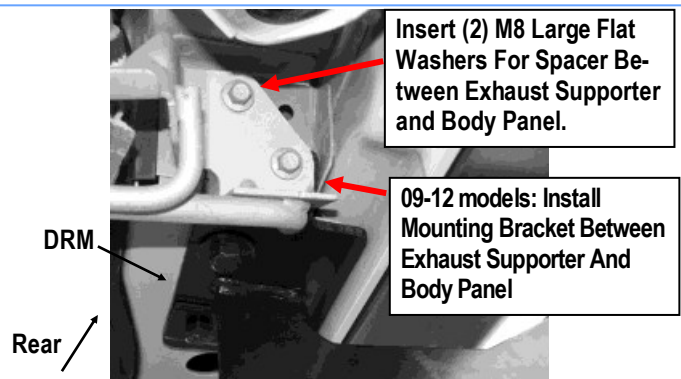

(Fig 11) 09-12 models Passenger Rear Mounting Bracket Installed



STEP 7

Once all (2) Driver side mounting brackets are installed, then proceed to the Step Bar installation. (**Figs 12 & 13**)

- (1) Select (1) Slider and (2) M8X1.25-35mm Carriage Bolts;
- (2) Install (2) M8X1.25-35mm Carriage Bolts in (1) Slider.
- (3) Slide the Slider (with carriage bolts) to the **Step Bar**.
- (4) Repeat to install the other (1) slider to the step bar.
- (5) Attach the Step Bar (with the Sliders) onto the installed mounting brackets. Position the Sliders to the installed brackets. Secure the Step Bar to the installed Brackets by using (4) M8 Large Flat Washers and (4) M8 Nylon Lock Nuts and (2) Sliders, (**Fig 13**). Do not fully tighten hardware at this time.

Note: The Sliders are packed with the Step Bars.

Level and adjust the Step Bar and fully tighten all hardware.

Repeat **Steps 1-7** for the other side Step Bar installation. **The installation is completed!!!**

Attention

Do periodic inspections to the installation to make sure that all hardware is secure and tight.

In order to protect your bars/boards, please use mild soap/non-abrasive products for cleaning only.

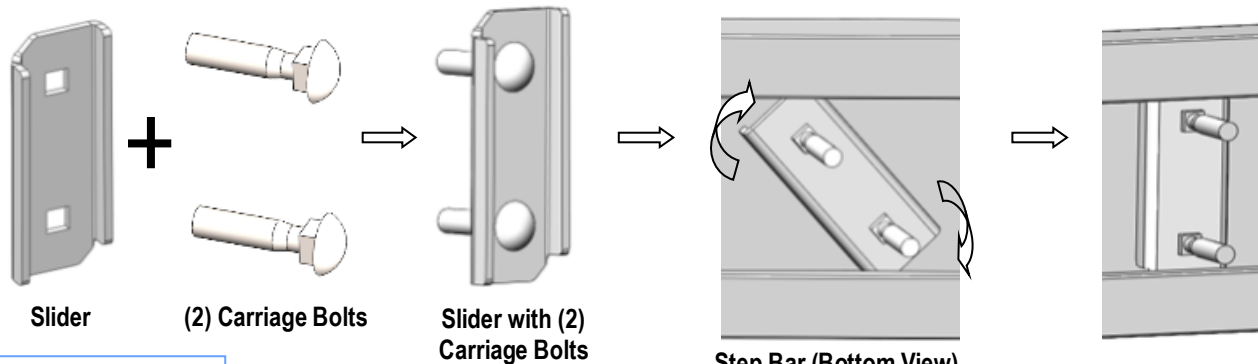

(Fig 12) Slider Installation

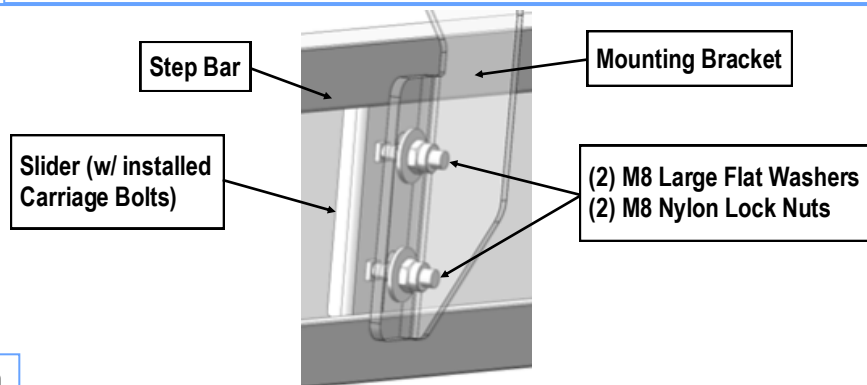

(Fig 13) Step Bar Installation