



**PART#: IB-P046Y&H**

# iBoard® Series

READ INSTRUCTIONS CAREFULLY BEFORE STARTING INSTALLATION. REMOVE CONTENTS FROM BOX AND VERIFY ALL PARTS ARE PRESENT. ASSISTANCE IS RECOMMENDED.

Fastener Size	Tightening Torque (ft-lbs)	Required
6mm	6-7	X
8mm	16-18	√
10mm	31-32	X
12mm	56-58	X
14mm	92-94	X

\*ROCKER PANEL MOUNT  
\*DRILLING IS REQUIRED

## PART LIST

Driver Side Step Bar

Front

Passenger Side Step Bar

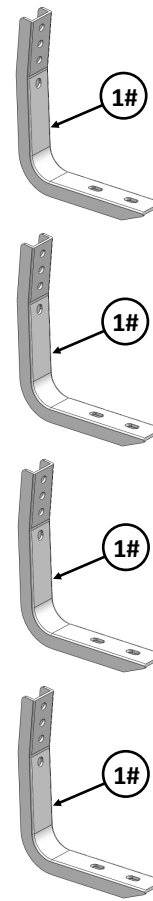
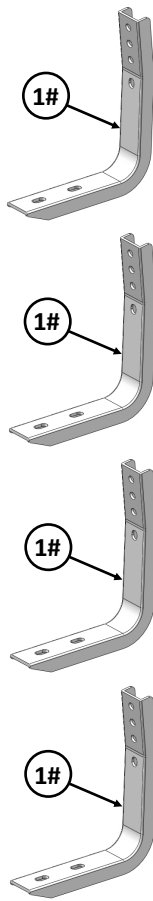



Scan for  
Installation Video

Hardware Package A (For Bracket Installation)					
Item	QTY	Description	Item	QTY	Description
1#	8	Mounting Brackets	4#	8	M8 Nylon Lock Nuts
2#	8	M8X1.25-20mm Hex Bolts	5#	16	ST6.3-25mm Hex Flange Self Tapping Screws
3#	16	M8 Large Flat Washers			

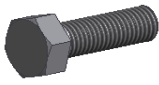

2 #



3 #



4 #

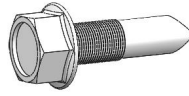

5 #

Hardware Package B (For Step Bar Installation)					
Item	QTY	Description	Item	QTY	Description
1#	16	M8X1.25-35mm Carriage Bolts	3#	16	M8 Nylon Lock Nuts
2#	16	M8 Large Flat Washers	4#	8	Sliders (Packed with Mounting Brackets)

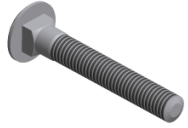

1 #



2 #

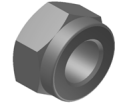

3 #



4 #



## STEP 1

Starting on the Driver side of the vehicle. Attach (1) Mounting Bracket to the rocker panel with (2) ST6.3-25mm Hex Flange Self Tapping Screws per bracket (Fig 1). Don't fully tighten at this time.

**Note: (8) Mounting Brackets Are Universal.**

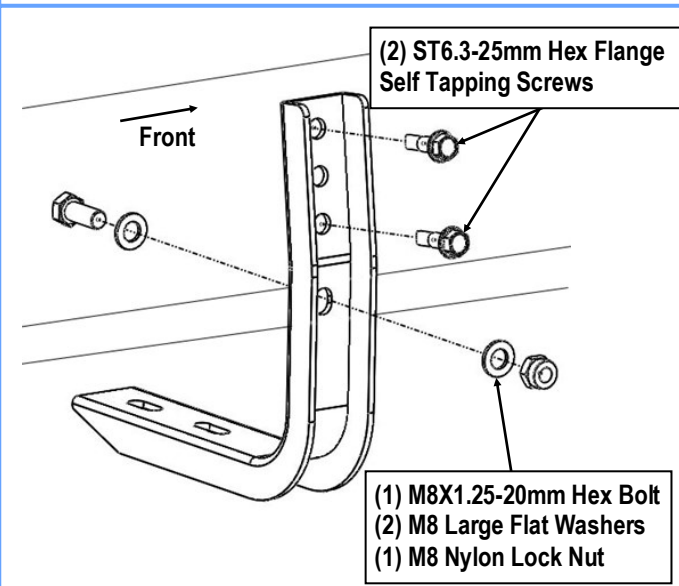

(Fig 1) Driver Side Mounting Bracket Installation

## STEP 2

Use the Mounting Bracket as template, mark and drill (4) 8mm holes in pinch weld. If necessary, remove the brackets from the rocker panel for drilling (Fig 2).

**Note: The dimensions on Fig 2 for reference only. It may be varied on some models.**

## STEP 3

Attach the Mounting Bracket onto the drilled holes on pinch weld with (1) M8X1.25-20mm Hex Bolt, (2) M8 Large Flat Washers and (1) M8 Nylon Lock Nut, (Fig 1). Don't fully tighten at this time.

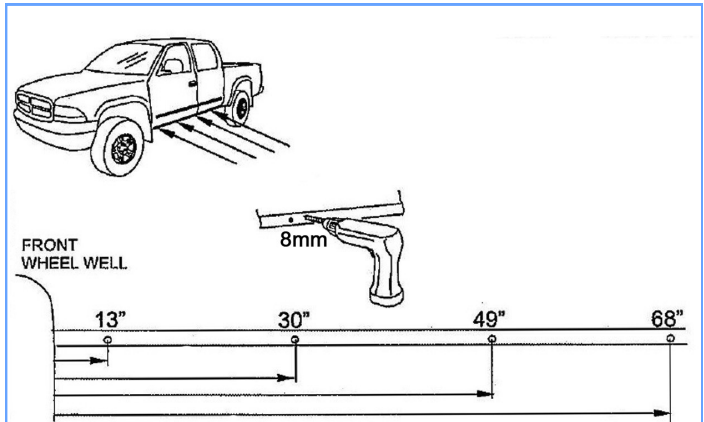

(Fig 2) Driver Side Pinch Weld Mounting Holes Drilling

## STEP 4

Once all (4) Driver side mounting brackets are installed, then proceed to the Step Bar installation. (Figs 3 & 4)

- (1) Select (1) Slider and (2) M8X1.25-35mm Carriage Bolts;
- (2) Install (2) M8X1.25-35mm Carriage Bolts in (1) Slider.
- (3) Slide the Slider (with carriage bolts) to the **Step Bar**.
- (4) Repeat to install the other (3) sliders to the step bar.

(5) Attach the Step Bar (with the Sliders) onto the installed mounting brackets. Position the Sliders to the installed brackets. Secure the Step Bar to the installed Brackets by using (8) M8 Large Flat Washers and (8) M8 Nylon Lock Nuts and (4) Sliders, (Fig 4). Do not fully tighten hardware at this time.

**Note:** The Sliders are packed with the Mounting Brackets.

Level and adjust the Step Bar and fully tighten all hardware.

Repeat **Steps 1-4** for the other side Step Bar installation. **The installation is completed!!!**

### Attention

**Do periodic inspections to the installation to make sure that all hardware is secure and tight.**

**In order to protect your bars/boards, please use mild soap/non-abrasive products for cleaning only.**

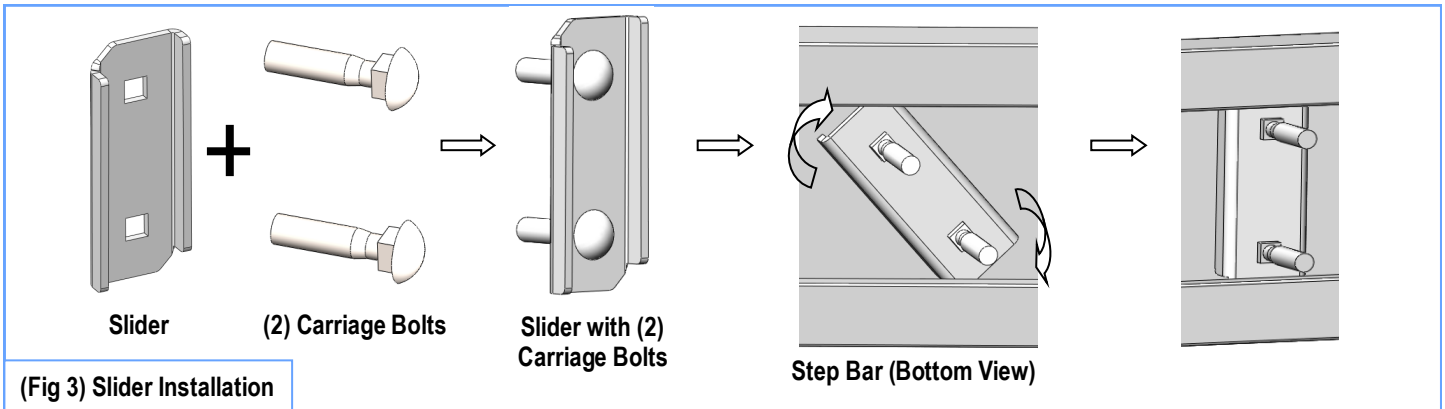

(Fig 3) Slider Installation

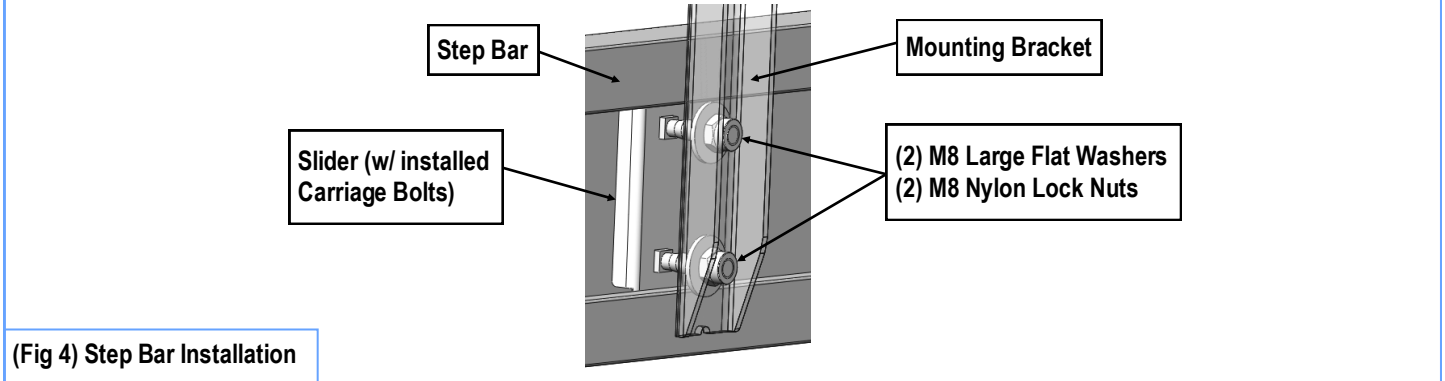

(Fig 4) Step Bar Installation