

iBoard®



Scan for
Installation Video

iBoard® by APS

PART#: IB-195S/195C&H

READ INSTRUCTIONS CAREFULLY BEFORE STARTING INSTALLATION. REMOVE CONTENTS FROM BOX AND VERIFY ALL PARTS ARE PRESENT. ASSISTANCE IS RECOMMENDED.

*ROCKER PANEL MOUNT
*CUTTING MAYBE REQUIRED

Fastener Size	Tightening Torque (ft-lbs)	Required
6mm	6-7	X
8mm	16-18	√
10mm	31-32	X
12mm	56-58	X
14mm	92-94	X

PART LIST

Driver Side Step Bar

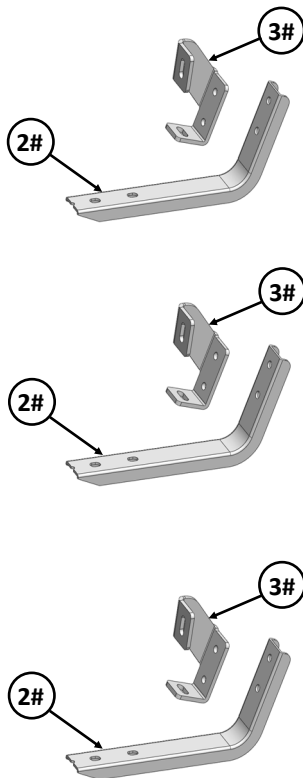
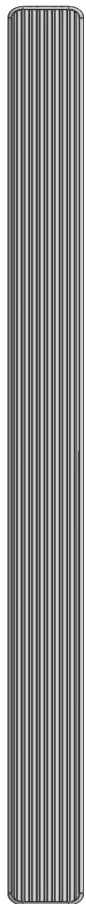

Front



Passenger Side Step Bar

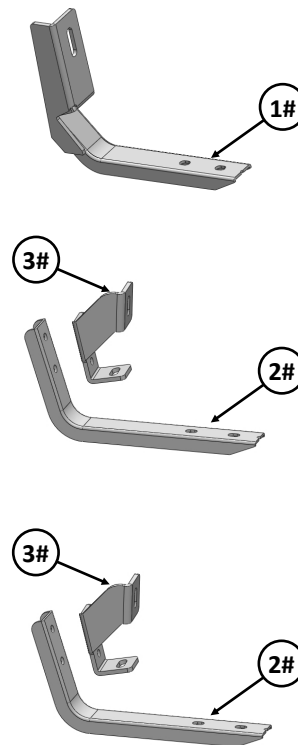
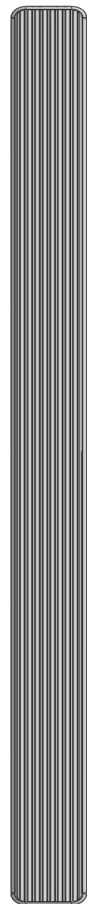

Customer Support: info@iboardauto.com



Mounting Bracket List					
Item	QTY	Description	Item	QTY	Description
1#	1	Passenger Front Mounting Bracket	3#	5	Mounting Plates
2#	5	Mounting Brackets			

Hardware Package A (For Bracket Installation)					
Item	QTY	Description	Item	QTY	Description
1#	1	SQ Spacer	6#	12	M8X1.25-25mm Hex Bolts
2#	10	M8X1.25-20mm Inner Hex Bolts	7#	13	M8 Large Flat Washers
3#	10	M8X1.25 Hex Flange Nuts	8#	13	M8 Lock Washers
4#	1	M8X1.25-35mm Hex Bolt	9#	11	M8 Clip Nuts
5#	1	M8X1.25 Nylon Lock Nut			

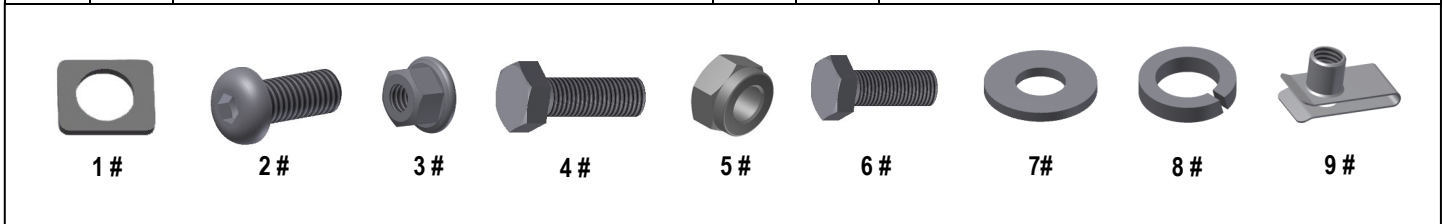

Hardware Package B (For Stainless Steel Step Bar Installation)					
Item	QTY	Description	Item	QTY	Description
1#	12	M8X1.25-35mm Carriage Bolts	3#	12	M8 Nylon Lock Nuts
2#	12	M8 Large Flat Washers	4#	6	Sliders (Packed with Step Bars)

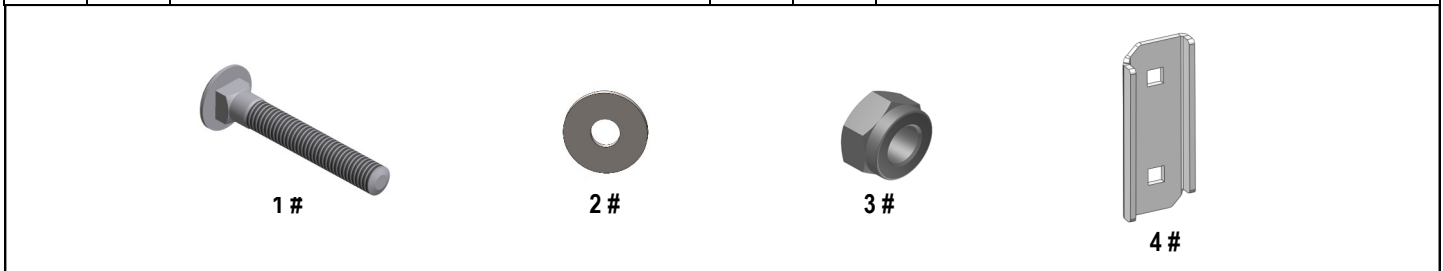



STEP 1

Start the installation under the driver side of the vehicle. Locate the 3 tabs along the bottom edge of the body, (pinch weld). Mounting Brackets will bolt to the 1st, 2nd and 4th mounting tabs, (Fig 1). Directly above each tab is a top mounting location on the side of the body panel. Hold a Bracket up in place to help determine the mounting holes to use along the body.

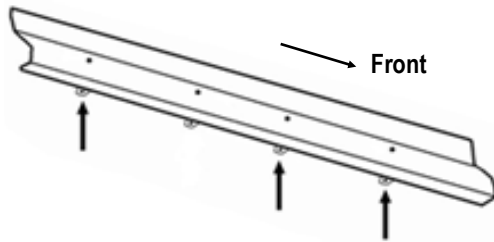

(Fig 1) Driver Side Mounting Locations

STEP 2

Determine the correct procedure for your model/year and each Bracket location.

Bottom mounting location on the edge of the pinch weld.

***Flat tab on pinch weld with factory installed weld nut:**

Thread M8 Hex Bolt into weld nut from the backside-down to clear paint from threads, (Fig 2).

***Flat tab on pinch weld with hole:**

Select (1) M8 Clip Nut. Slide the M8 Clip Nut over the tab with the nut facing up behind the tab, (Figs 3—5). Line up threaded nut with hole in tab. Repeat for each mounting location.

Top mounting location on the back side of the body panel.

***Models with factory installed threaded insert in body panel:**

Thread M8 Hex Bolt into threaded insert to clear paint as required, (Fig 2 & 3).

***Large and small hole in side of body panel:**

Remove the rubber plug from the larger hole, (Fig 4). Select (1) M8 Clip Nut. Slide the M8 Clip Nut into the larger hole. Line up the threaded nut with the smaller hole, (Fig 5).

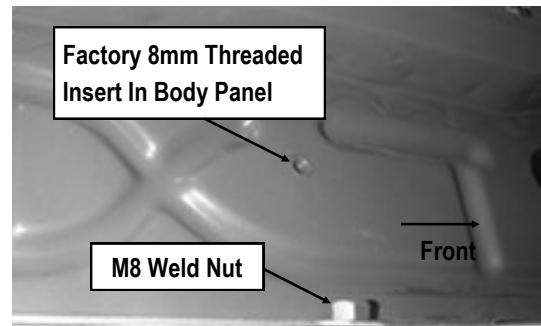

(Fig 2) Driver Side Front Mounting Location

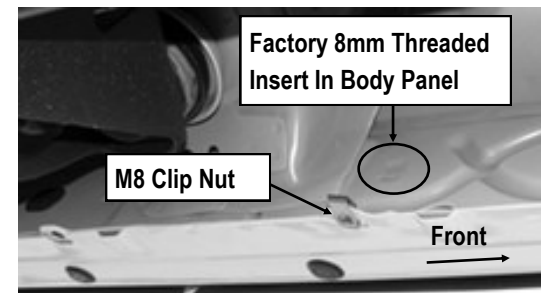

(Fig 3) Driver Side Center Mounting Location

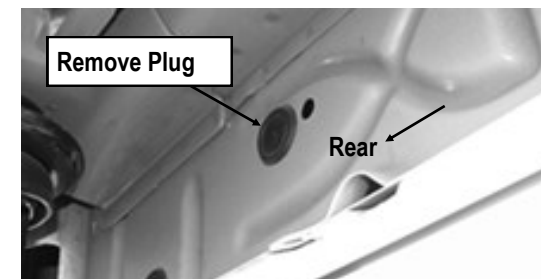

(Fig 4) Driver Side Rear Center Mounting Location

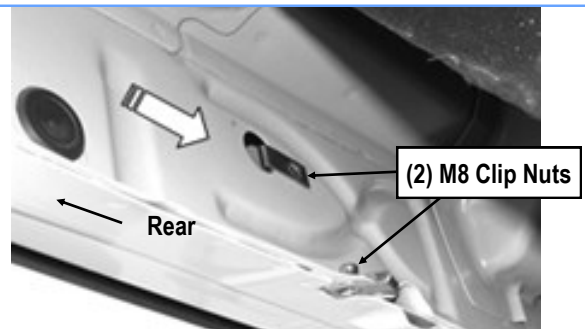

(Fig 5) Driver Side Rear Mounting Location



STEP 3

Assemble Driver Front Mounting Bracket and Driver Front Mounting Plate as shown (**Fig 6**). And then Bolt the Assembled Mounting Bracket to the M8 Clip Nuts and/or the factory threaded holes on Driver Side Front Mounting Location with (2) M8 x1.25-25mm Hex Bolts, (2) M8 Lock Washers and (2) M8 Large Flat Washers, (**Fig 7**). Snug but do not fully tighten the hardware.

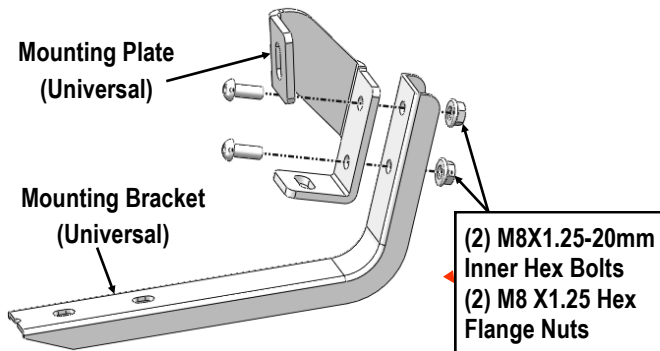

(Fig 6) Driver Front Mounting Bracket Assembly

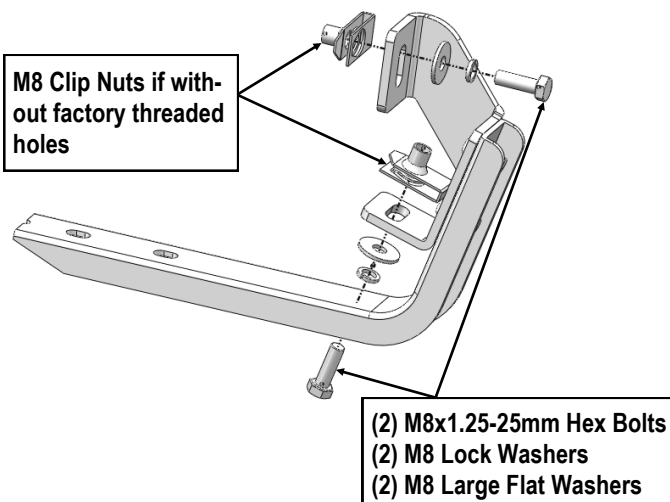

(Fig 7) Driver Front Brackets Installation

STEP 4

Repeat **Steps 1-3** to install (2) remaining driver side Brackets.

STEP 5

Once all (3) Driver side mounting brackets are installed, then proceed to the Step Bar installation. (**Figs 8 & 9**)

- (1) Select (1) Slider and (2) M8X1.25-35mm Carriage Bolts;
- (2) Install (2) M8X1.25-35mm Carriage Bolts in (1) Slider.
- (3) Slide the Slider (with carriage bolts) to the **Step Bar**.
- (4) Repeat to install the other (2) sliders to the step bar.
- (5) Attach the Step Bar (with the Sliders) onto the installed mounting brackets. Position the Sliders to the installed brackets. Secure the Step Bar to the installed Brackets by using (6) M8 Large Flat Washers and (6) M8 Nylon Lock Nuts and (3) Sliders, (**Fig 9**). Do not fully tighten hardware at this time.

Note: The Sliders are packed with the Step Bars.

Level and adjust the Step Bar and fully tighten all hardware.

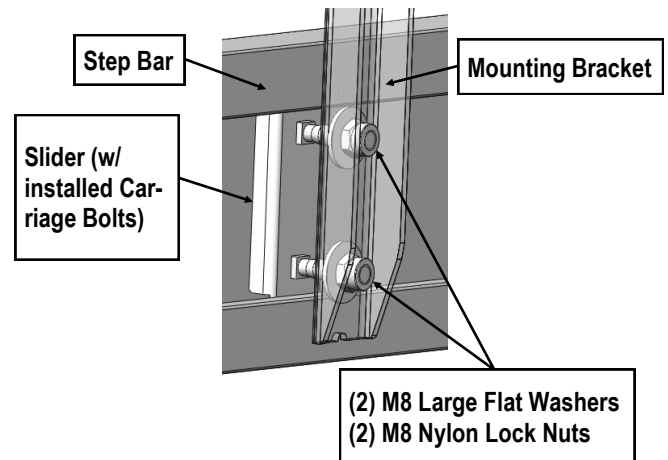

(Fig 9) Step Bar Installation

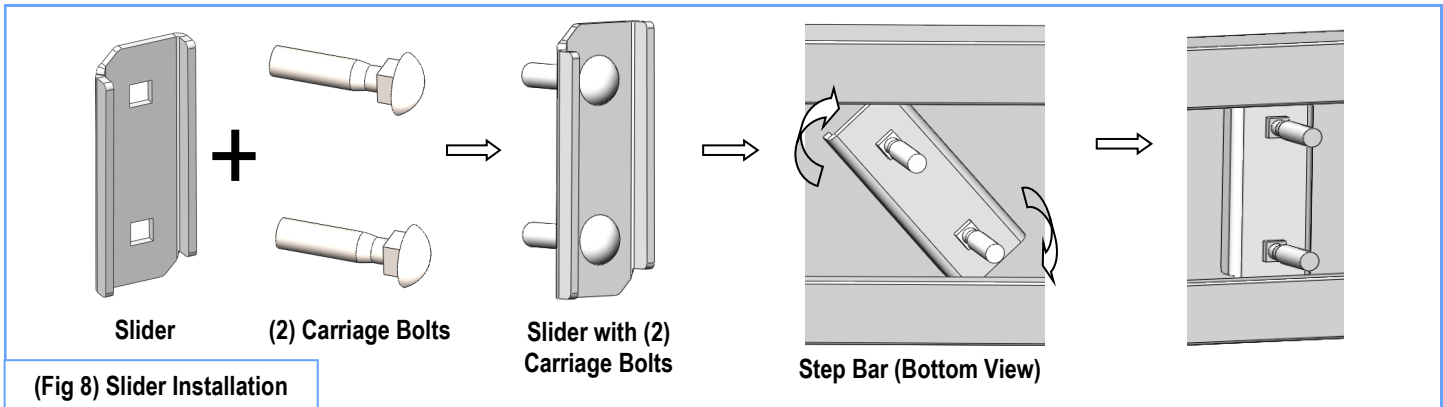

STEP 6

Move to the passenger side of the vehicle. On the passenger side, determine if the vehicle is equipped with a plastic diesel exhaust fluid (DEF) tank, (Fig 10 & 11).

Models without DEF tank, skip to Step 7.

Models with DEF tank: The tank sits close to the side of the body. With specialized tools, the Passenger Front Mounting Bracket can be installed but room is limited. It may be easier to drop the tank down to access the inner side of the body panel for bracket installation. Tank will not need to be removed, only dropped down for access to mounting location.

IMPORTANT: If tank is full, it will be very heavy and assistance is highly recommended to avoid injury or damage to the vehicle or the tank. It is recommended that installation is performed when the DEF tank is low on fluid before dropping the tank.

- For 07-16 Models:** with plastic lower tray under the tank, remove the (3) hex bolts attaching the tray to the frame, (Fig 10), and remove the tray. **For 2017-Up 2500/3500 models:** Remove the (4) hex bolts attaching the plastic cover to DEF tank, (Fig 11A) and remove the plastic cover, (Fig 11B).
- Release the tank filler hose. Release the plug for the sending unit on the top of the tank.
- Support the tank with a floor jack. Place a smooth flat surface, (wooden block for example), between the floor jack and the tank to avoid damaging the plastic tank. Do not push up on the tank; only support the weight of the

tank with the jack.

- Remove the (2) bolts securing the tank straps to the vehicle, (Fig 12). Tilt the straps to release from the brackets. Slowly lower the tank until the top of the tank is almost visible. Use blocks or stands to support the tank while installing the front Brackets.
- Proceed to **Step 7**.

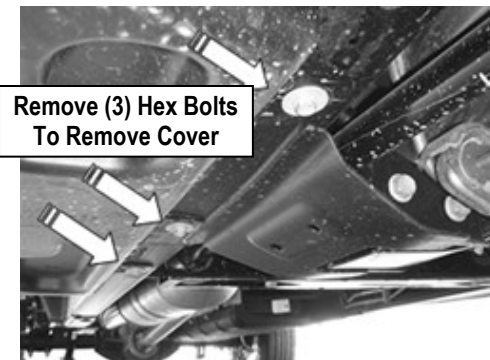

(Fig 10) 07-16 Passenger Side Front With DEF Tank Cover

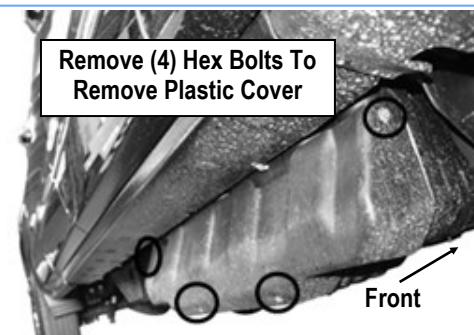

(Fig 11A) 2017-Up Passenger Side Pictured With DEF Plastic Tank Cover.

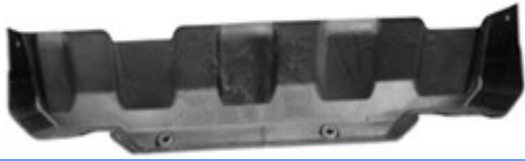

(Fig 11B) 2017 Passenger Side DEF Cover

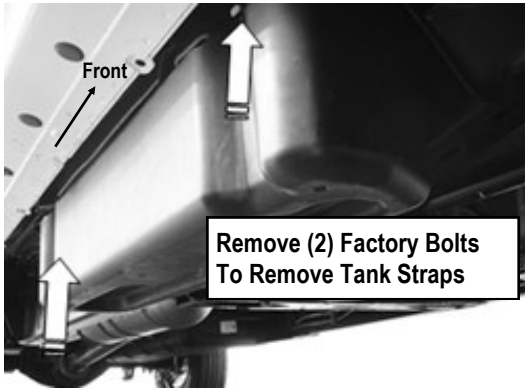

(Fig 12) 07-16 Passenger Side DEF Tank And Cover

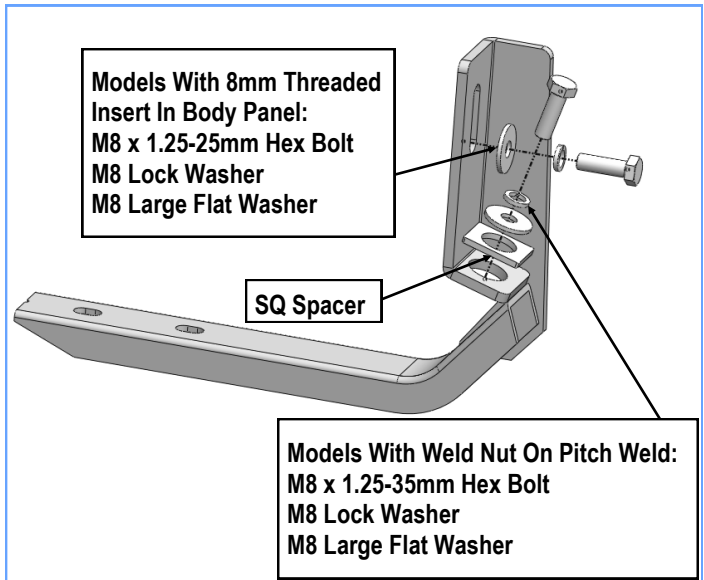

(Fig 14) Passenger Front Mounting Bracket Installation (Weld Nut If Equipped-Also See Fig 2)

STEP 7

Locate the first tab on the edge of the pinch weld, attach the Passenger Front Mounting Bracket (PFM) to the Weld pinch weld and top body panel (Fig 13 & 14):

- Models with flat tab and hole:** see Fig 13. Leave loose at this time.
- Models with weld-nut:** see Fig 14. Leave loose at this time.

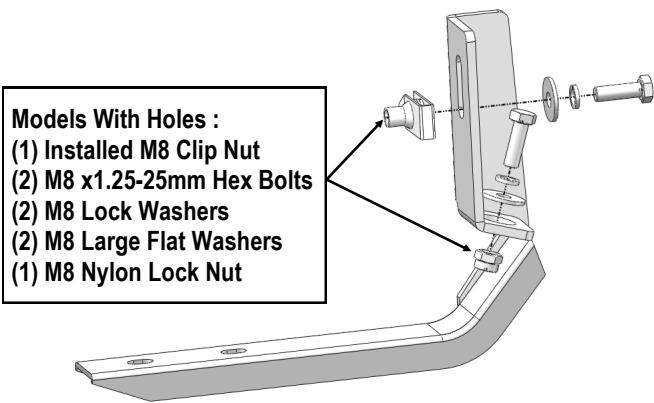

(Fig 13) Passenger Front Mounting Bracket Installation

STEP 8

Repeat **Steps 2—4** for the (2) remaining passenger side mounting brackets installations.

2017-up 2500/3500 DEF tank models: Locate the 2nd tab bracket location along the bottom edge of the body, (pinch weld), (Fig 15). Hold the DEF cover in place and mark the 2nd Bracket location onto the cover, (Fig 16). Use a sharp knife or hacksaw blade to carefully cut a slot in the plastic cover to clear the 2nd Bracket, (Fig 17). Remove as little plastic as possible.

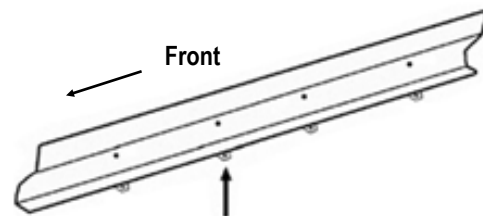

(Fig 15) Passenger 2nd Mounting Bracket Location From Back Of Body Panel

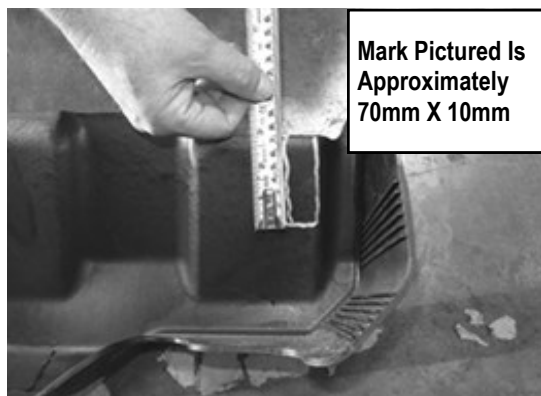

(Fig 16) 2017-Up Passenger Side DEF Cover Marked For Trimming

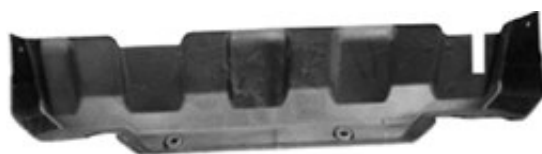

(Fig 17) 2017-Up Passenger Side DEF Cut For Example Only

STEP 9

Repeat **Step 5** to install the passenger side Step Bar.

STEP 10

Once the Step Bars are installed and all hardware fully tightened, reinstall the DEF tank and cover, if equipped, as described in **Step 6**.

The installation is completed!!!

Attention

Do periodic inspections to the installation to make sure that all hardware is secure and tight.

In order to protect your bars/boards, please use mild soap/non-abrasive products for cleaning only.