

iBoard®



Scan for
Installation Video

iBoard® by APS

PART#: IB-R331

READ INSTRUCTIONS CAREFULLY BEFORE STARTING INSTALLATION. REMOVE CONTENTS FROM BOX AND VERIFY ALL PARTS ARE PRESENT. ASSISTANCE IS RECOMMENDED.

*ROCKER PANEL MOUNT
*NO DRILLING REQUIRED

Fastener Size	Tightening Torque (ft-lbs)	Required
6mm	6-7	√
8mm	16-18	√
10mm	31-32	X
12mm	56-58	X
14mm	92-94	X

Driver

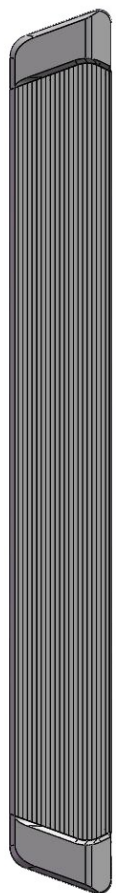

Front



Passenger

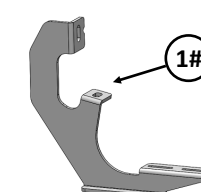
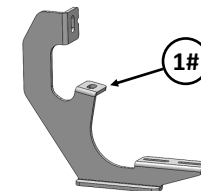
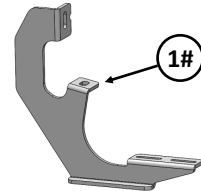
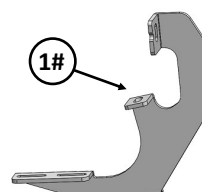
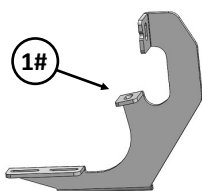
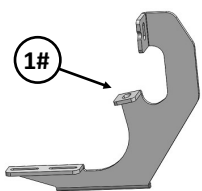



Scan for
Installation Video

Hardware Package A (For Bracket Installation)

Item	QTY	Description	Item	QTY	Description
1#	6	Mounting Brackets	3#	12	M8 Large Flat Washers
2#	12	M8X1.25-30mm Hex Bolts	4#	12	M8 Lock Washers



2 #



3 #



4#

Hardware Package B (For Step Bar Installation)

Item	QTY	Description	Item	QTY	Description
1#	12	M6X1-20mm Square Head Bolts	3#	12	M6 Nylon Lock Nuts
2#	12	M6 Large Flat Washers			

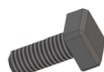

1#



2#



3#



STEP 1

Start installation from the driver side front of the vehicle, (**Fig 1**). Locate the 6 plugs along the bottom edge of the body, Mounting Brackets will be bolted to the 1st, 2nd and 4th threaded mounting holes. Remove the plastic plugs from each mounting location, (**Fig 2**). Directly above each threaded insert is a top mounting location on the side of the body panel. Hold a Bracket up in place to help determine the mounting holes to use along the body.

NOTE: Thread an 8mm Hex Bolt into the threaded inserts to clear paint as required.

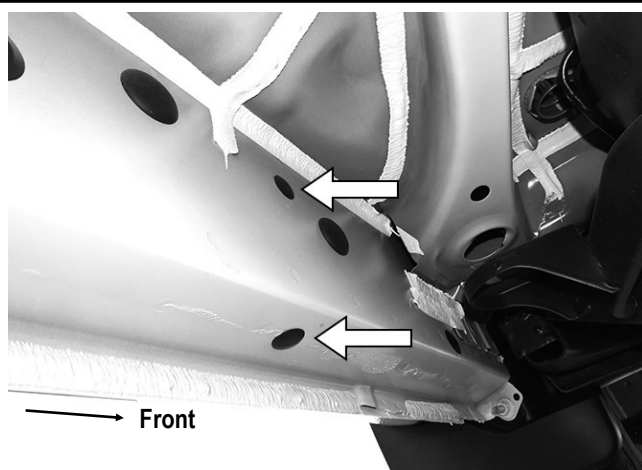

(Fig 1) Driver Front Mounting Location
(Driver Side Mounting Brackets will Bolt to 1st, 2nd, 4th Locations)

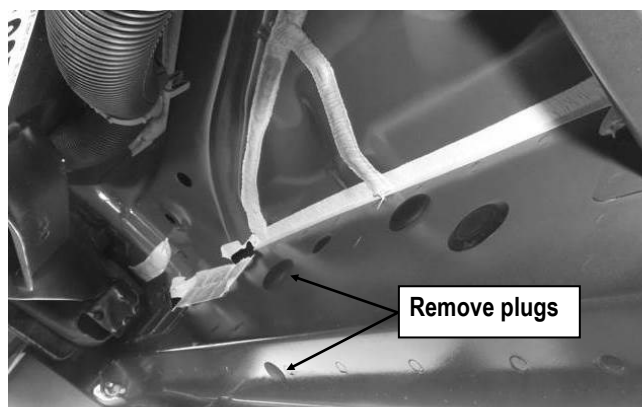

(Fig 2) Remove Plastic Plugs to Uncover Threaded Inserts

STEP 2

Select (1) Mounting Bracket. Bolt the Mounting Bracket to the factory threaded holes with (2) M8X1.25-30mm Hex Bolts, (2) M8 Large Flat Washers and (2) M8 Lock Washers (**Fig 3**). Don't fully tighten hardware at this time.

Note: (6) Mounting Brackets are universal.

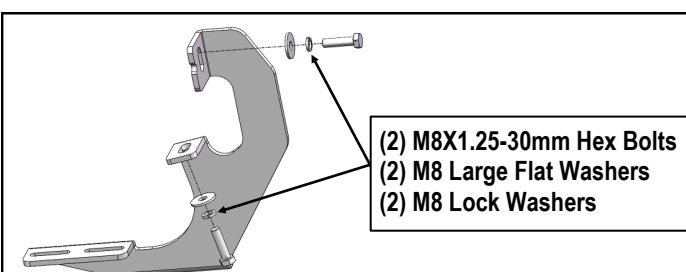

(Fig 3) Driver Front Mounting Bracket Installed

STEP 3

Move along the side panel to the driver side center and rear Mounting Locations, (**Figs 4 & 5**). Repeat **Steps 1 & 2** to install the Driver Center & Rear Mounting Brackets

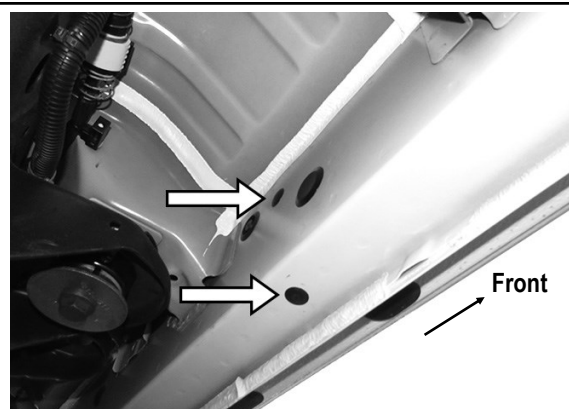

(Fig 4) Driver Side Center Mounting Location

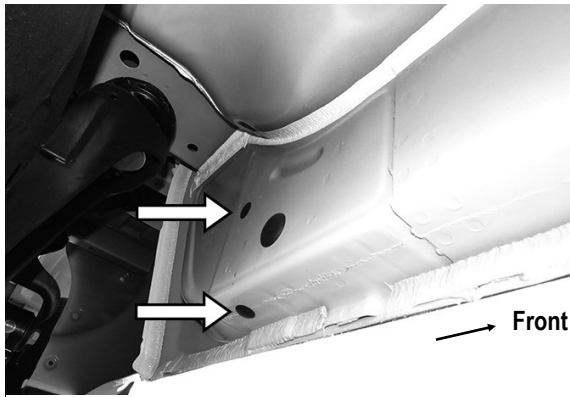

(Fig 5) Driver Rear Side Mounting Location

STEP 4

Once all (3) mounting brackets are installed. Select a Running Board. Slip (3) M6X1-20mm Square Head Bolts into each bottom channel (**Fig 6**). Carefully position the Running Board onto the (3) Mounting Brackets. Attach the Running Board to each Mounting Bracket with (2) M6X1-20mm Square Head Bolts, (2) M6 Large Flat Washers and (2) M6 X1 Nylon Lock Nuts (**Fig 7**). Do not fully tighten at this time.

IMPORTANT: Do not slide the Running Board on the Brackets or the bottom surface of the board will be damaged.

M6X1-20mm Square Head Bolts

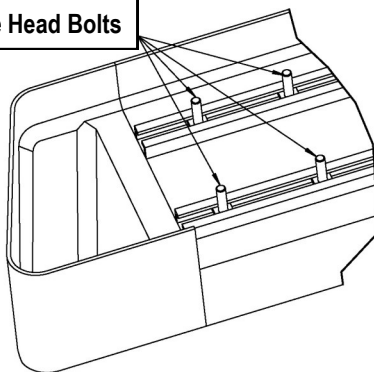

(Fig 6) Slip M6X1-20mm Square Head Bolts Into The Bottom Channels

(2) M6X1-20mm Square Head Bolts
(2) M6 Large Flat Washers
(2) M6 Nylon Lock Nuts

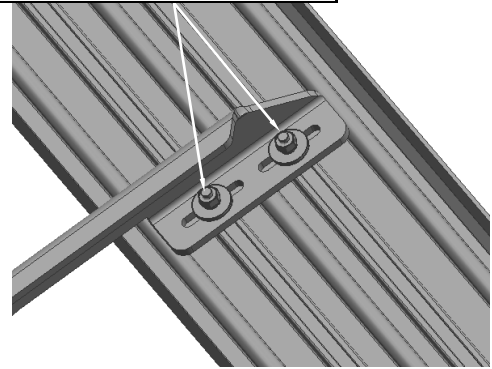

(Fig 7) Running Board Installed Onto Mounting Bracket

STEP 5

Level and adjust the Running Board and fully tighten all hardware.

Important: Please follow the recommended Tightening Torques shown in the table on page 1. Don't over tighten, or the nuts/bolts will be damaged.

STEP 6

Repeat **Steps 1-5** for the other side Running Board installation. The installation is completed .

Attention

Do periodic inspections to the installation to make sure that all hardware is secure and tight.

In order to protect your bars/boards, please use mild soap/non-abrasive products for cleaning only.