



iBoard® Series

INSTALLATION INSTRUCTIONS

PART#: IB-R071/R195

BEFORE INSTALLATION

REMOVE CONTENTS FROM BOX. VERIFY ALL PARTS ARE PRESENT. READ INSTRUCTIONS CAREFULLY BEFORE STARTING INSTALLATION. ASSISTANCE IS RECOMMENDED. THANK YOU FOR CHOOSING OUR PRODUCT!

These instructions are provided for reference only. We strongly recommend installation by a professional installer for the best results. We are not responsible for any damage caused during installation.

***ROCKER PANEL MOUNT**

***NO DRILLING REQUIRED**

Torque Value

Fastener Size	Tightening Torque (ft-lbs)	Required
6mm	6-7	√
8mm	16-18	√
10mm	31-32	X
12mm	56-58	X
14mm	92-94	X



Scan for
Installation Video

Hardware Package A (For Bracket Installation)					
Item	QTY	Description	Item	QTY	Description
A1	14	M8X1.25-25mm Hex Bolts	A4	12	M8 Clip Nuts
A2	16	M8 Large Flat Washers	A5	2	M8 Nylon Lock Nuts
A3	12	M8 Lock Washers			

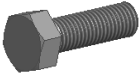

A1



A2



A3

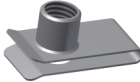

A4



A5

Hardware Package B (For Running Board Installation)					
Item	QTY	Description	Item	QTY	Description
B1	12	M6X1-20mm Square Head Bolts	B3	12	M6 Nylon Lock Nuts
B2	12	M6 Large Flat Washers			

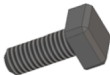

B1



B2



B3



Scan for
Installation Video

Mounting Bracket List			
Item	QTY	Bracket Label	Description
1#	5	DFM	Mounting Bracket for Driver Side/ Passenger Center /Rear
2#	1	PFM	Mounting Bracket for Passenger Front
3#	1	PFB	Bar Brackets for Passenger Front

PART LIST

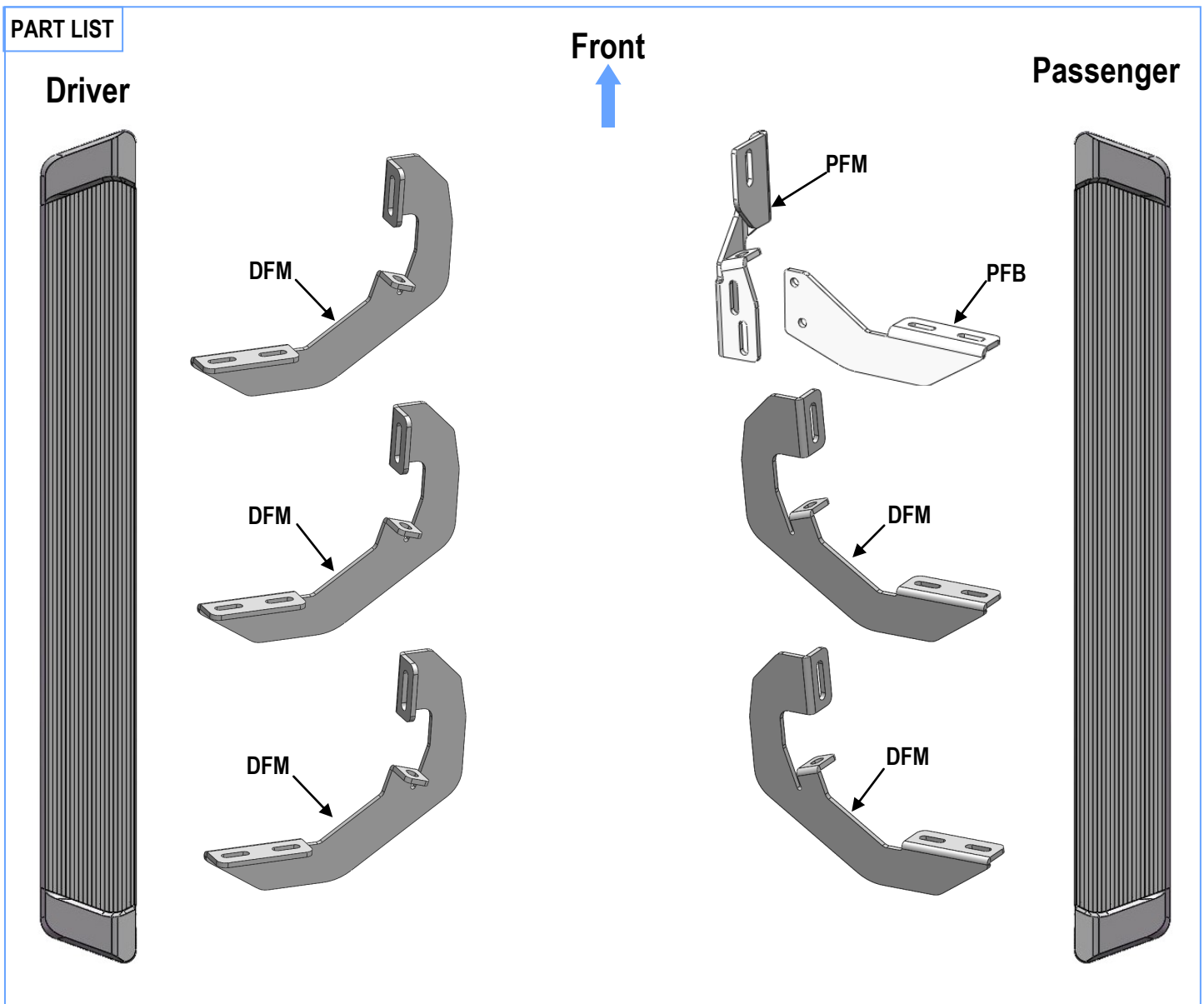



STEP 1: Locate Driver Side Mounting Positions

1. Start the installation under the driver side of the vehicle.
 - Locate the 5 tabs along the bottom edge of the body, (pinch weld).
 - Mounting Brackets will be bolted to the 1st, 2nd and 4th mounting tabs, (Fig 1).
 - Directly above each tab is a top mounting location on the side of the body panel.

NOTE: It will be helpful for identifying the mounting holes to hold up a mounting bracket in place.

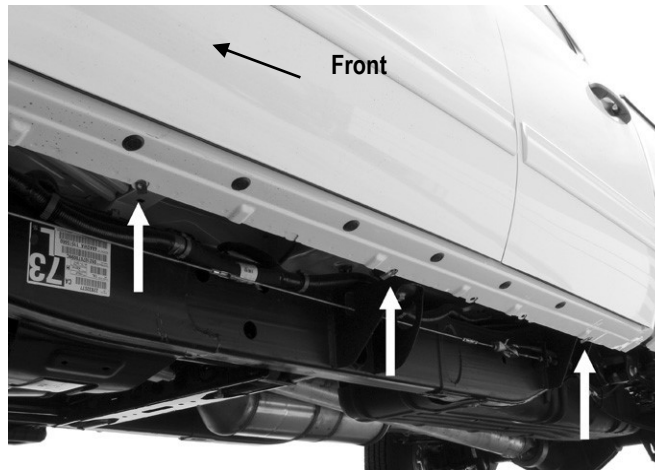

(Fig 1) Driver Side (3) Mounting Locations

2. Determine the correct procedure for your model year and each Bracket location.

(1) Lower mounting location (on the edge of the pinch weld):

a. Flat tab on pinch weld with factory installed weld nut:

Thread A1 (M8X1.25-25mm Hex Bolt) into weld nut from to clear up the paint from threads, (Fig 2).

b. Flat tab on pinch weld with hole:

Select (1) A4 (M8 Clip Nut) . Slide the (1) A4 (M8 Clip Nut) over the tab with the nut facing up behind the tab, (Figs 3—5).

Line up threaded nut with hole in tab. Repeat for each mounting location.

(2) Upper mounting location (on the back of the body panel):

a. Models with factory installed threaded insert in body panel:

Thread A1 (M8X1.25-25mm Hex Bolt) into threaded insert to clear paint as required, (Fig 2 & 3).

b. Models with large and small hole on back side of body panel:

Remove the rubber plug from the larger hole, (Fig 4). Select (1) A4 (M8 Clip Nut) . Slide the (1) A4 (M8 Clip Nut) into the larger hole. Line up the threaded nut with the smaller hole, (Fig 5).

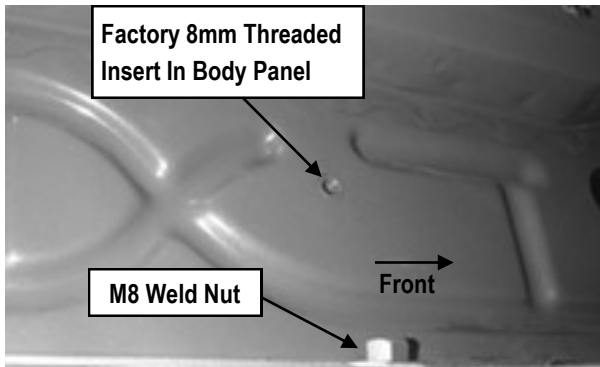

(Fig 2) Driver Front Mounting Bracket Location

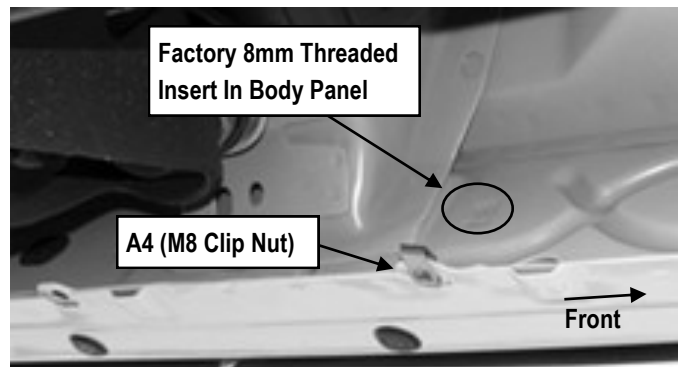

(Fig 3) Driver Side Center Mounting Location

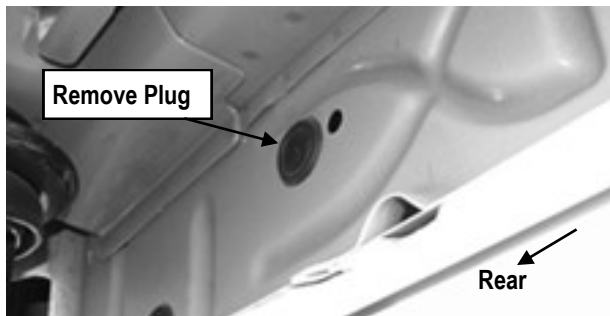

(Fig 4) Driver Side Rear Mounting Location
(With Rubber Plug on Mounting Hole)

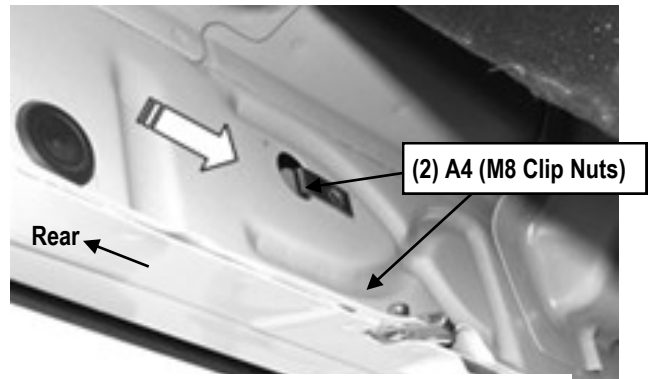

(Fig 5) Clip Nuts Installation (Typical)

STEP 2: Install the Driver Front Mounting Bracket

Bolt the (1) Mounting Bracket (DFM) to the installed A4 (M8 Clip Nuts) and/or the factory threaded holes on Driver Side Front Mounting Location (Fig 6) with:

- (2) A1 (M8 X1.25-25mm Hex Bolts)
- (2) A3 (M8 Lock Washers)
- (2) A2 (M8 Large Flat Washers)

Do not fully tighten the hardware at this time.

(2) A1 (M8 X1.25-25mm Hex Bolts)
(2) A3 (M8 Lock Washers)
(2) A2 (M8 Large Flat Washers)



(Fig 6) Driver Front Mounting Bracket Installed



STEP 3: Install the Driver Center& Rear Mounting Brackets

Repeat **Steps 1-2** to install the (2) Mounting Bracket (**DFM**) on Driver Center& Rear Mounting Locations.

Note: All (5) Mounting Brackets (DFM) Are Universal.

STEP 4: Driver Side Running Board Installation

Once all (3) mounting brackets are installed, then proceed to the Running Board installation.

(1) Select a Running Board. Slide (3) B1 M6X1-20mm Square Head Bolts into each bottom channel (**Fig 7**).

(2) Carefully position the Running Board onto the (3) Mounting Brackets.

(3) Attach the Running Board to each Mounting Bracket (**Fig 8**) with:

- (2) B1 (M6X1-20mm Square Head Bolts)
- (2) B2 (M6 Large Flat Washers)
- (2) B3 (M6 Nylon Lock Nuts)

Note: Do not slide the Running Board on the Brackets or the bottom surface of the board will be damaged.

M6X1-20mm Square Head Bolts

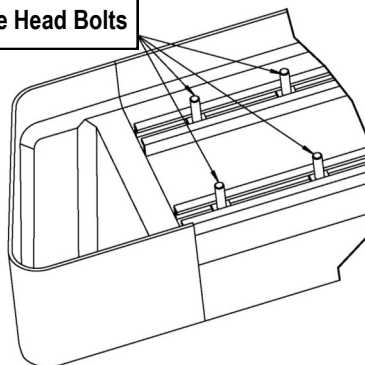

(Fig 7) Slip M6X1-20mm Square Head Bolts Into The Bottom Channels

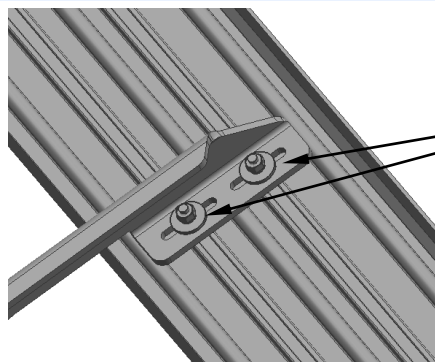

- (2) B1 (M6X1-20mm Square Head Bolts)
- (2) B2 (M6 Large Flat Washers)
- (2) B3 (M6 Nylon Lock Nuts)

(Fig 8) Running Board Installed Onto Mounting Bracket



STEP 5: Locate Passenger Side Mounting Positions

Move to the passenger side of the vehicle. On the passenger side, determine if the vehicle is equipped with a plastic diesel exhaust fluid (DEF) tank, (Figs 9 & 10).

(1) Models without DEF tank, skip to Step 6.

(2) Models with DEF tank:

- The tank sits close to the side of the body.
- With specialized tools, the Passenger Front Mounting Bracket can be installed but room is limited.
- Determine model/year of vehicle before proceeding.

A) Up to 2016 models:

- It may be easier to drop the tank down to access the inner side of the body panel for the Passenger Side Front Mounting Bracket installation.
- Tank will not need to be removed, only dropped down for access to mounting location.

IMPORTANT: If tank is full, it will be very heavy and assistance is highly recommended to avoid injury or damage the vehicle or the tank. It is recommended that installation is performed when the DEF tank is low on fluid before dropping the tank.

- On models with plastic lower tray under the tank, remove the (3) hex bolts attaching the tray to the frame, (Fig 9), and remove the tray.
- Release the tank filler hose. Release the plug for the sending unit on the top of the tank.
- Support the tank with a floor jack. Place a smooth flat surface, (wooden block for example), between the floor jack and the tank to avoid damaging the plastic tank. Do not push up on the tank; only support the weight of the tank with the jack.
- Remove the (2) bolts securing the tank straps to the vehicle, (Fig 10). Tilt the straps to release from the brackets. Slowly lower the tank until the top of the tank is almost visible. Use blocks or stands to support the tank while installing the Passenger Front Mounting Bracket.
- Proceed to **Step 7**.

B) 2017-Up models:

Remove the (4) hex bolts attaching plastic cover to DEF tank, (Fig 11A) and remove plastic cover, (Fig 11B).

NOTE: On 2017 2500/3500 models, only remove plastic cover from DEF tank. Do not lower DEF tank and proceed to Step 7.

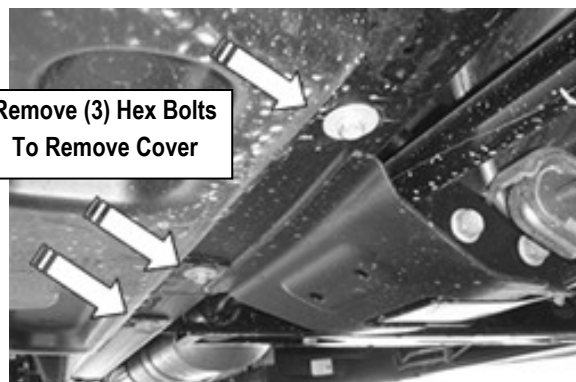

Remove (3) Hex Bolts
To Remove Cover

(Fig 9) 07-16 Passenger Side Front Pictured With DEF Tank Cover

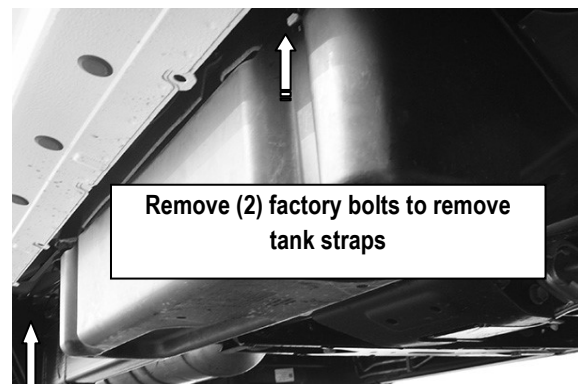

Remove (2) factory bolts to remove
tank straps

(Fig 10) 07-16 Passenger Side DEF Tank and Cover

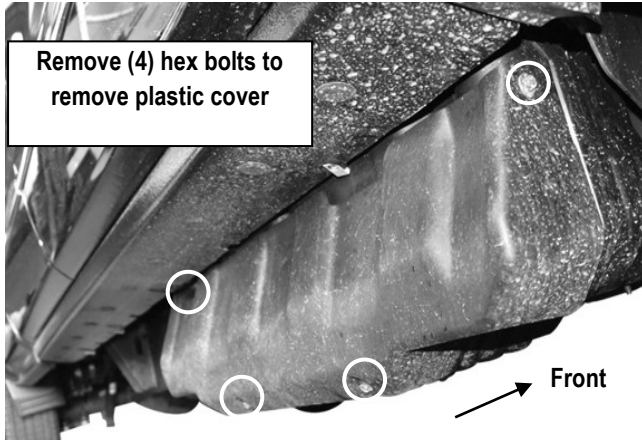

(Fig 11A) 2017-Up Passenger Side Pictured w/DEF tank cover.

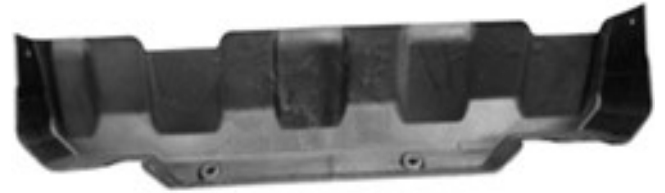

(Fig 11B) 2017 Passenger Side DEF Cover Removed

STEP 6: Install the Passenger Front Mounting Brackets

1. Assembled Passenger Front Mounting Brackets (PFM+PFB) (Fig 12) with:

- (2) A1 (M8X1.25-25mm Hex Bolts)
- (4) A2 (M8 Large Flat Washers)
- (2) A5 (M8 Nylon Lock Nuts)

Do not fully tighten the hardware at this time.

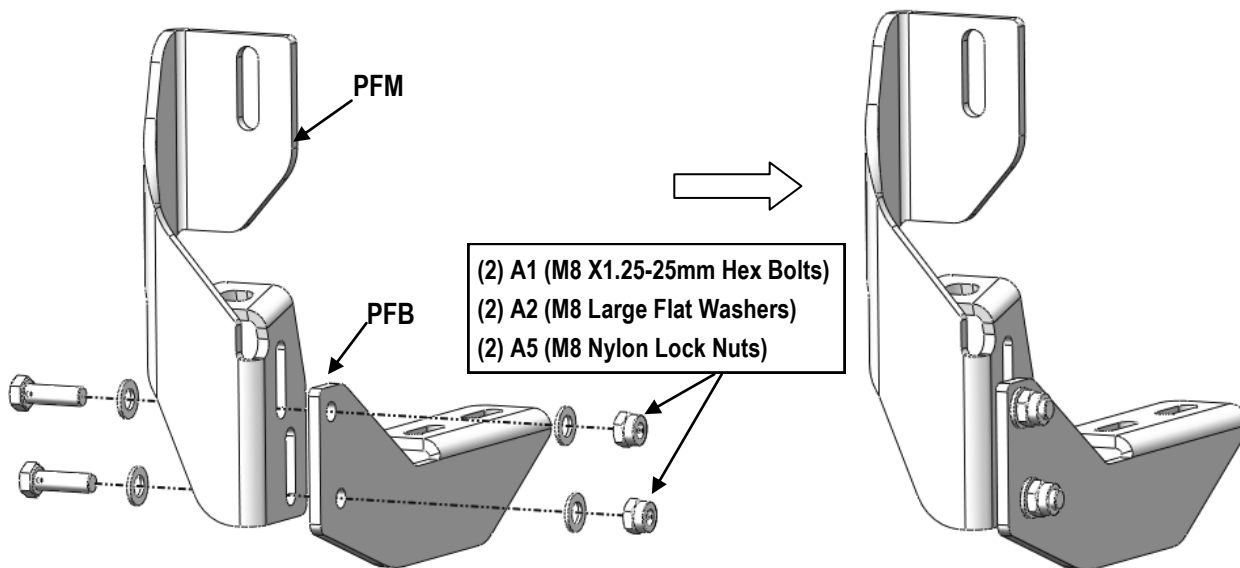

(Fig 12) Passenger Front Mounting Brackets (PFM+PFB) Assembly



2. Locate the first tab on the edge of the pinch weld, attach the Passenger Front Mounting Bracket (**PFM+PFB**) to the A4 (Clip Nut) and/or the factory threaded holes. (**Fig 13 & 14**):

- a. **Models with flat tab and hole:** see Fig 13. Leave loose at this time.
- b. **Models with weld-nut::** see Fig 14. Leave loose at this time.

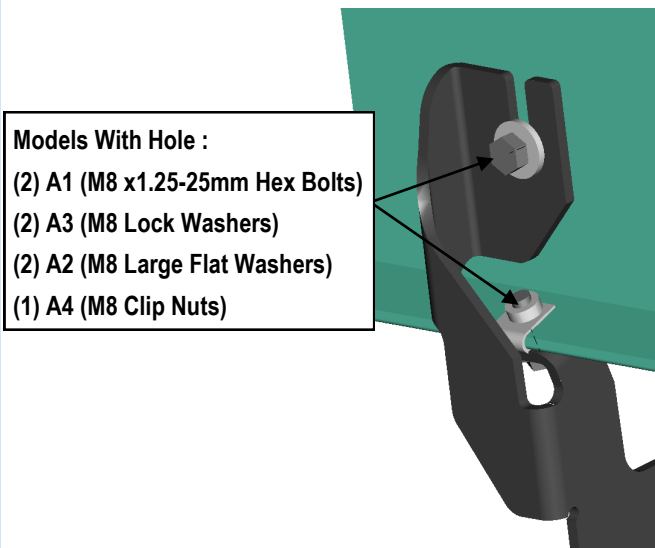

(Fig 13) Passenger Front Mounting Bracket Installed (Typical)

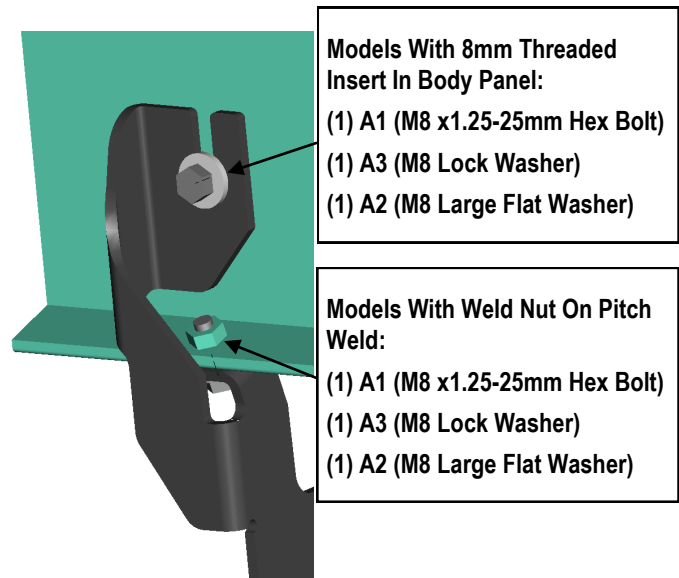

(Fig 14) Passenger Front Mounting Bracket Installed (Weld Nut If Equipped-Also See Fig 2) (Typical)

STEP 7: Install Passenger Center& Rear Mounting Brackets

1. **2007-2016 models:** Repeat **Steps 1-3** for the (2) remaining Passenger Side Mounting Brackets (**DFM**) installations.

2. **2017-up 2500/3500 DEF tank models:**

- Locate the 2nd tab bracket location along the bottom edge of the body, (pinch weld), (**Fig 15**).
- Hold the DEF cover in place and mark the 2nd Bracket location onto the cover, (**Fig 16**).
- Use a sharp knife or hacksaw blade to carefully cut a slot in the plastic cover to clear the 2nd Bracket, (**Fig 17**).
- Remove as little plastic as possible.

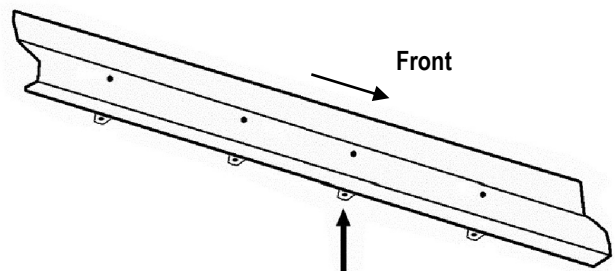

(Fig 15) Passenger 2nd Mounting Bracket Location From Back Of Body Panel

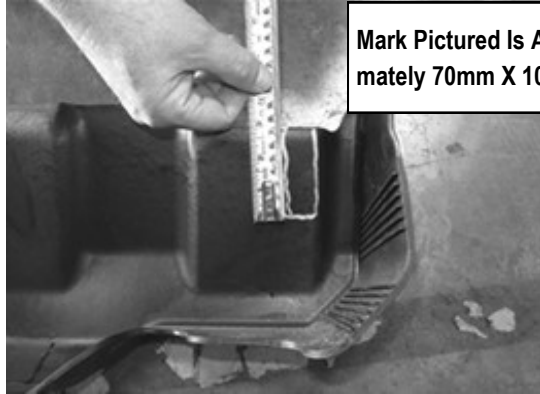

Mark Pictured Is Approximately 70mm X 10mm

(Fig 15) 2017-Up Passenger Side DEF Cover Marked For Trimming

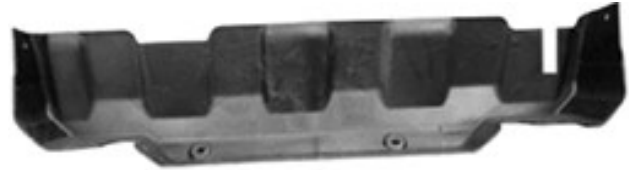

(Fig 16) 17-Up Passenger Side DEF Cut For Example Only

STEP 8: Passenger Side Running Board Installation

Repeat **Step 4** to install the passenger side Running Board .

STEP 9: Adjustment

- Level and adjust the assembled Running Board properly.
- Tighten all 6mm hardware with 6-7 ft-lbs torque and 8mm hardware with 16-18 ft-lbs torque.
- Once the Running Board are installed and all hardware fully tightened, reinstall the DEF tank and cover, if equipped, as described in **Step 5**. The installation is completed .

Attention

Do periodic inspections to the installation to make sure that all hardware is secure and tight.
In order to protect your bars/boards, please use mild soap/non-abrasive products for cleaning only.