

# iBoard®



Scan for  
Installation Video

## iBoard® by APS

PART#: IB-P071Y&H

READ INSTRUCTIONS CAREFULLY BEFORE STARTING INSTALLATION. REMOVE CONTENTS FROM BOX AND VERIFY ALL PARTS ARE PRESENT. ASSISTANCE IS RECOMMENDED.

\*ROCKER PANEL MOUNT  
\*NO DRILLING REQUIRED/CUTTING MAYBE REQUIRED

Fastener Size	Tightening Torque (ft-lbs)	Required
6mm	6-7	X
8mm	16-18	√
10mm	31-32	X
12mm	56-58	X
14mm	92-94	X

### PART LIST

Driver Side Step Bar

Front



Passenger Side Step Bar

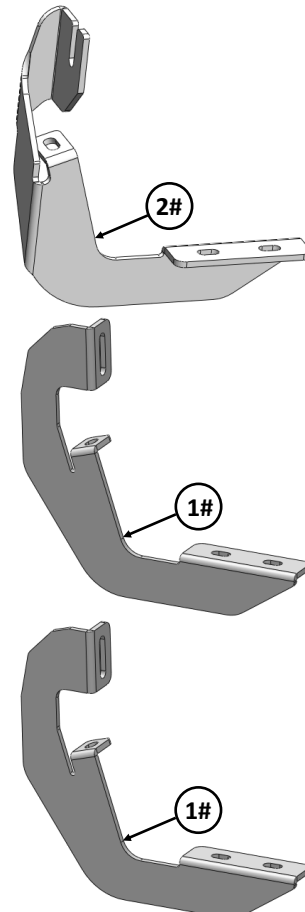
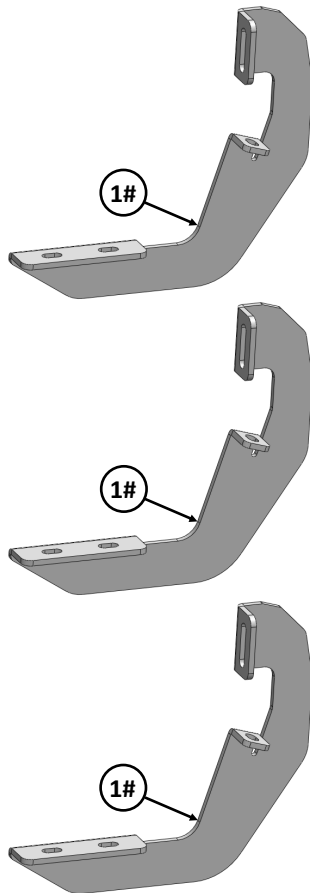
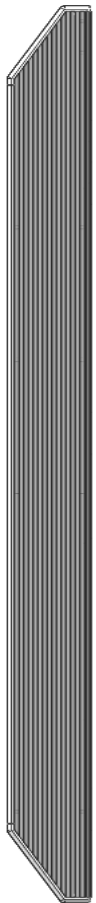





Scan for  
Installation Video

Mounting Bracket List					
Item	QTY	Description	Item	QTY	Description
1#	5	Mounting Brackets	2#	1	Passenger Front Mounting Bracket

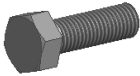
Hardware Package A (For Bracket Installation)					
Item	QTY	Description	Item	QTY	Description
1#	12	M8X1.25-25mm Hex Bolts	3#	12	M8 Lock Washers
2#	12	M8 Large Flat Washers	4#	12	M8 Clip Nuts



1#



2#



3#

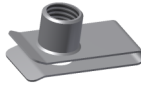

4#

Hardware Package B (For Step Bar Installation)					
Item	QTY	Description	Item	QTY	Description
1#	12	M8X1.25-35mm Carriage Bolts	3#	12	M8 Nylon Lock Nuts
2#	12	M8 Large Flat Washers	4#	6	Sliders (Packed with Mounting Brackets)

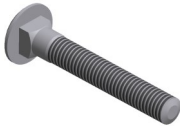

1#



2#



3#



4#



## STEP 1

Start the installation under the driver side of the vehicle. Locate the 3 tabs along the bottom edge of the body, (pinch weld). Mounting Brackets will be bolted to the 1st, 2nd and 4th mounting tabs, (Fig 1). Directly above each tab is a top mounting location on the side of the body panel. Hold a Bracket up in place to help determine the mounting holes to be used on the body.

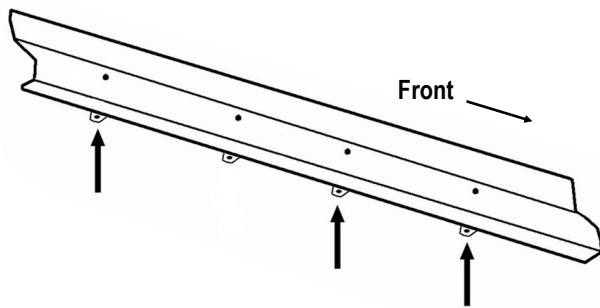

(Fig 1) Driver Side Mounting Locations

## STEP 2

Determine the correct procedure for your model year and each Bracket location.

**Lower mounting location (on the edge of the pinch weld):**

**\*Flat tab on pinch weld with factory installed weld nut:**

Thread M8 Hex Bolt into weld nut from to clear up the paint from threads, (Fig 2).

**\*Flat tab on pinch weld with hole:**

Select (1) M8 Clip Nut. Slide the M8 Clip Nut over the tab with the nut facing up behind the tab, (Figs 3—5). Line up threaded nut with hole in tab. Repeat for each mounting location.

**Upper mounting location (on the back of the body panel):**

**\*Models with factory installed threaded insert in body panel:**

Thread M8 Hex Bolt into threaded insert to clear paint as required, (Fig 2 & 3).

**\*Large and small hole on back side of body panel:**

Remove the rubber plug from the larger hole, (Fig 4). Select (1) M8 Clip Nut. Slide the M8 Clip Nut into the larger hole. Line up the threaded nut with the smaller hole, (Fig 5).

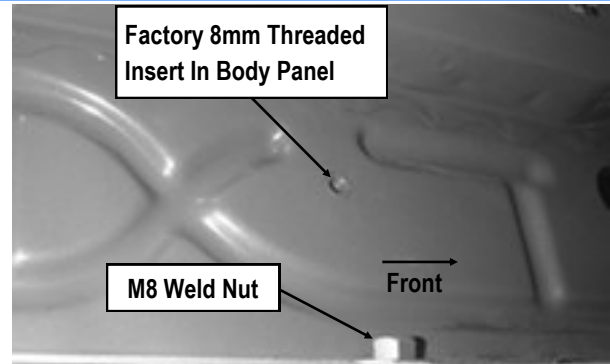

(Fig 2) Driver Front Mounting Bracket Location

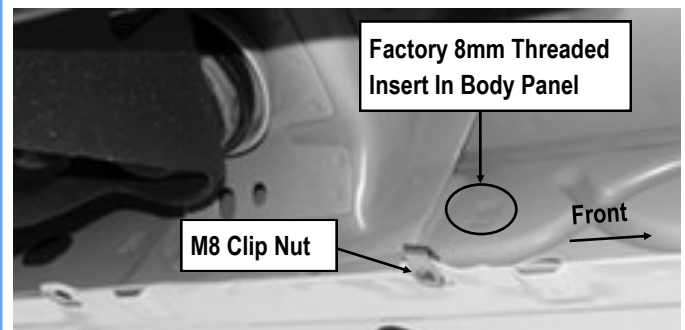

(Fig 3) Driver Side Center Mounting Location

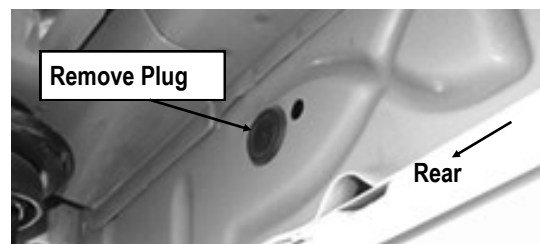

(Fig 4) Driver Side Center Mounting Location  
(With Rubber Plug on Mounting Hole)

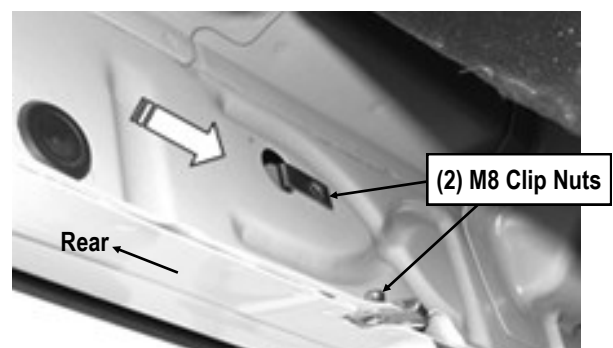

(Fig 5) Driver Side Rear Mounting Location



## STEP 3

Select (1) Driver Front Mounting Bracket, bolt the Mounting Bracket to the installed M8 Clip Nuts and/or the factory threaded holes on Driver Side Front Mounting Location with (2) M8 X1.25-25mm Hex Bolts, (2) M8 Lock Washers and (2) M8 Large Flat Washers, (Fig 6). Snug but do not fully tighten the hardware.

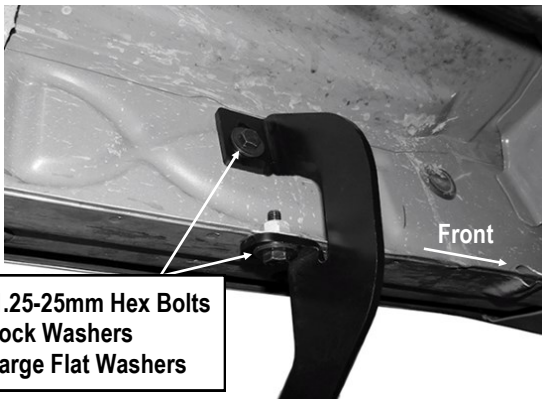

(Fig 6) Driver Front Mounting Bracket Installed

## STEP 4

Repeat **Steps 1-3** to install the driver side center/rear Bracket.

## STEP 5

Once all (3) Driver side mounting brackets are installed, then proceed to the Step Bar installation. (Figs 7 & 8)

- (1) Select (1) Slider and (2) M8X1.25-35mm Carriage Bolts;
- (2) Install (2) M8X1.25-35mm Carriage Bolts in (1) Slider.
- (3) Slide the Slider (with carriage bolts) to the **Step Bar**.
- (4) Repeat to install the other (2) sliders to the step bar.
- (5) Attach the Step Bar (with the Sliders) onto the installed mounting brackets. Position the Sliders to the installed brackets. Secure the Step Bar to the installed Brackets by using (6) M8 Large Flat Washers and (6) M8 Nylon Lock Nuts and (3) Sliders, (Fig 8). Do not fully tighten hardware at this time.

**Note:** The Sliders are packed with the Mounting Brackets.  
Level and adjust the Step Bar and fully tighten all hardware.

## STEP 6

Move to the passenger side of the vehicle. On the passenger side, determine if the vehicle is equipped with a plastic diesel exhaust fluid (DEF) tank, (Fig 9 & 10).

**Models without DEF tank, skip to Step 7.**

**Models with DEF tank:** The tank sits close to the side of the body. With specialized tools, the Passenger Front Mounting Bracket can be installed but room is limited. It may be easier to drop the tank down to access the inner side of the body panel for bracket installation. Tank will not need to be removed, only dropped down for access to mounting location.

**IMPORTANT:** If tank is full, it will be very heavy and assistance is highly recommended to avoid injury or damage the vehicle or the tank. It is recommended that installation is performed when the DEF tank is low on fluid before dropping the tank.

- a. **For 07-16 Models:** with plastic lower tray under the tank, remove the (3) hex bolts attaching the tray to the frame, (Fig 9), and remove the tray.
- b. **For 2017-Up 2500/3500 models:** Remove the (4) hex bolts attaching the plastic cover to DEF tank, (Fig 10A) and remove the plastic cover, (Fig 10B).
- c. Release the tank filler hose. Release the plug for the sending unit on the top of the tank.
- d. Support the tank with a floor jack. Place a smooth flat surface, (wooden block for example), between the floor jack and the tank to avoid damaging the plastic tank. Do not push up on the tank; only support the weight of the tank with the jack.
- e. Remove the (2) bolts securing the tank straps to the vehicle, (Fig 11). Tilt the straps to release from the brackets. Slowly lower the tank until the top of the tank is almost visible. Use blocks or stands to support the tank while installing the front Brackets.
- f. Proceed to **Step 7**.

# iBoard®



Scan for  
Installation Video

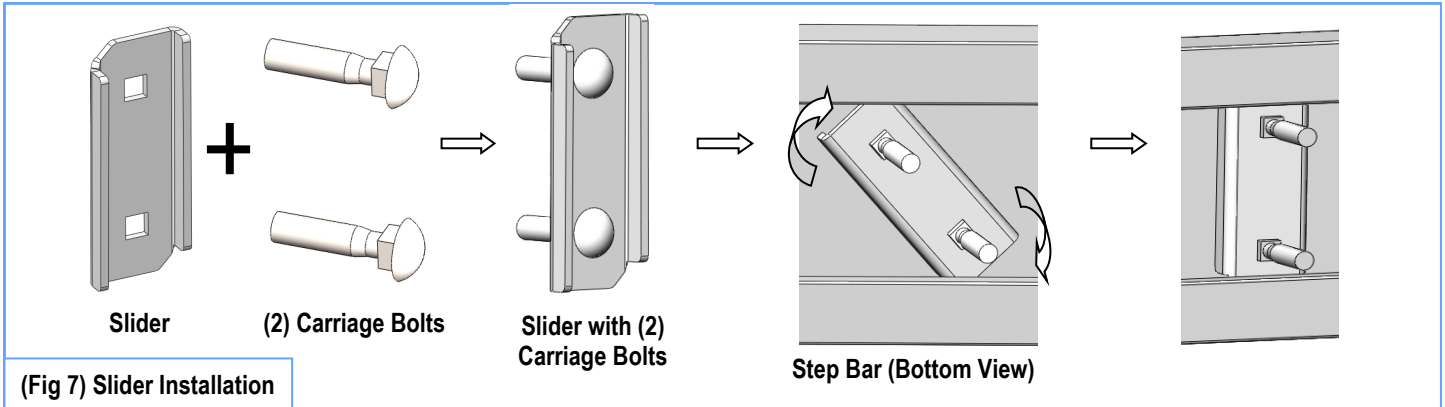

(Fig 7) Slider Installation

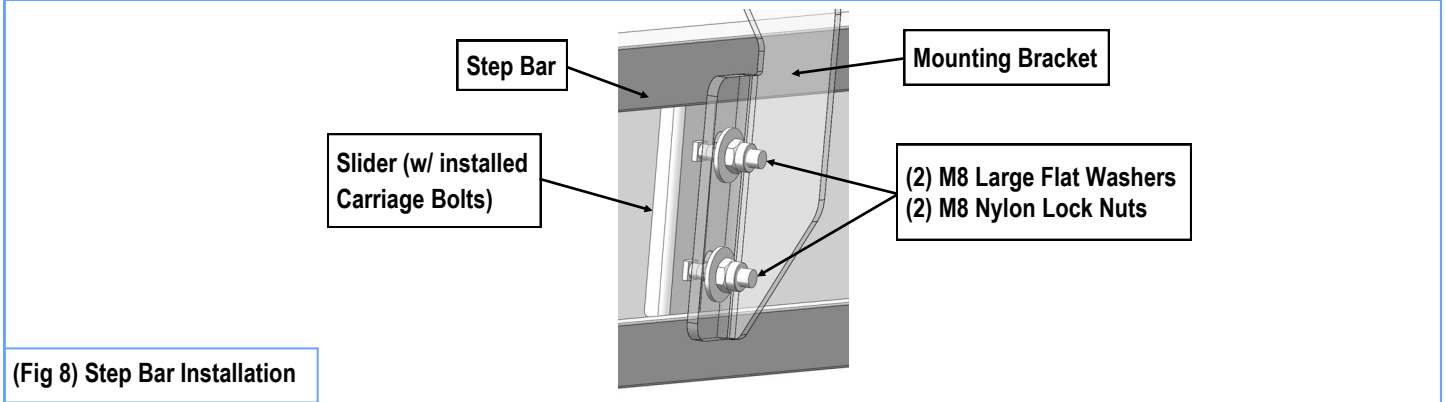

(Fig 8) Step Bar Installation

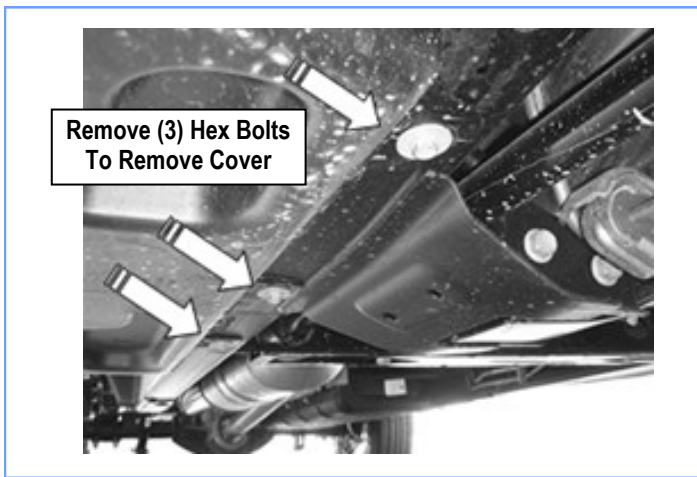

(Fig 9) 07-16 Passenger Side Front Pictured With DEF Tank Cover

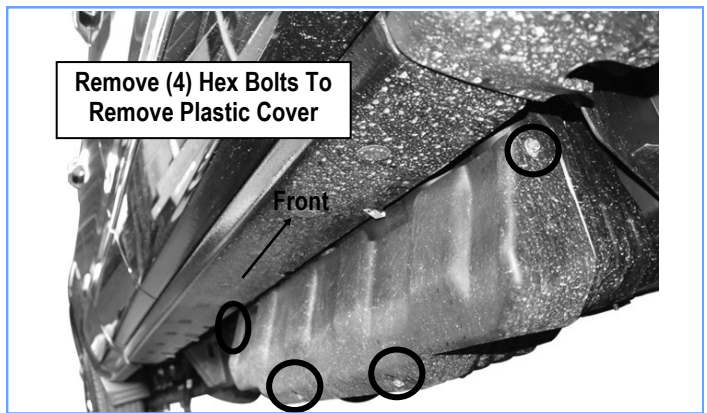

(Fig 10A) 2017-Up 2500/3500 Models Passenger Side (With DEF Plastic Tank Cover)

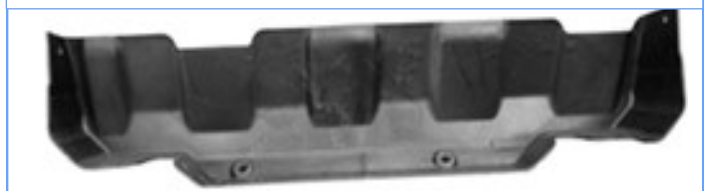

(Fig 10B) 2017 Passenger Side DEF Cover Removed



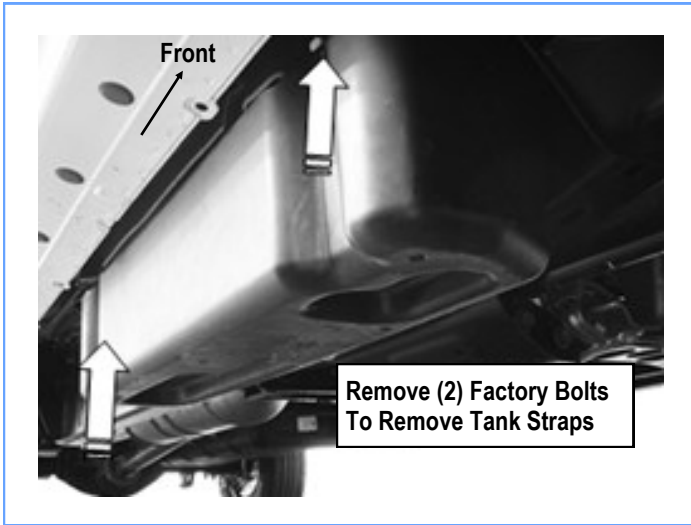

Remove (2) Factory Bolts  
To Remove Tank Straps

(Fig 11) 07-16 Passenger Side DEF Tank And Cover

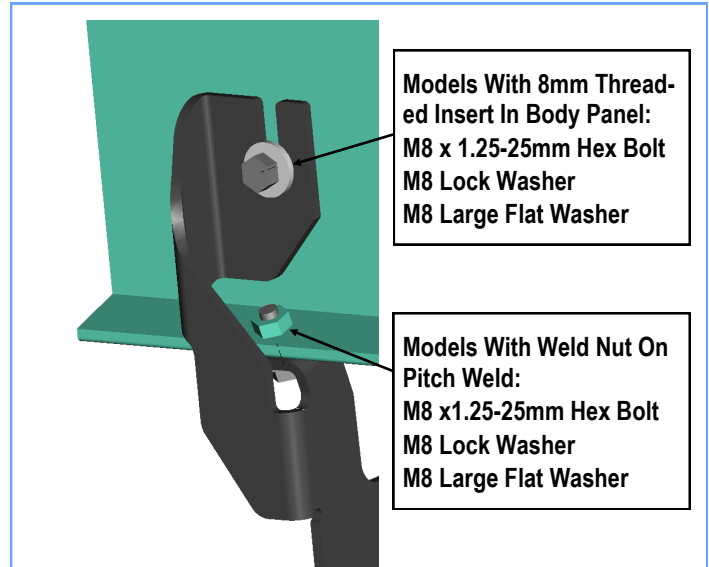

Models With 8mm Threaded Insert In Body Panel:  
M8 x 1.25-25mm Hex Bolt  
M8 Lock Washer  
M8 Large Flat Washer

Models With Weld Nut On Pitch Weld:  
M8 x1.25-25mm Hex Bolt  
M8 Lock Washer  
M8 Large Flat Washer

(Fig 13) Passenger Front Mounting Bracket Installed  
(Weld Nut If Equipped-Also See Fig 2)

## STEP 7

Locate the first tab on the edge of the pinch weld, attach the Passenger Front Mounting Bracket to the pinch weld and top body panel (Fig 12 & 13):

- Models with flat tab and hole:** see Fig 12. Leave loose at this time.
- Models with weld-nut:** see Fig 13. Leave loose at this time.

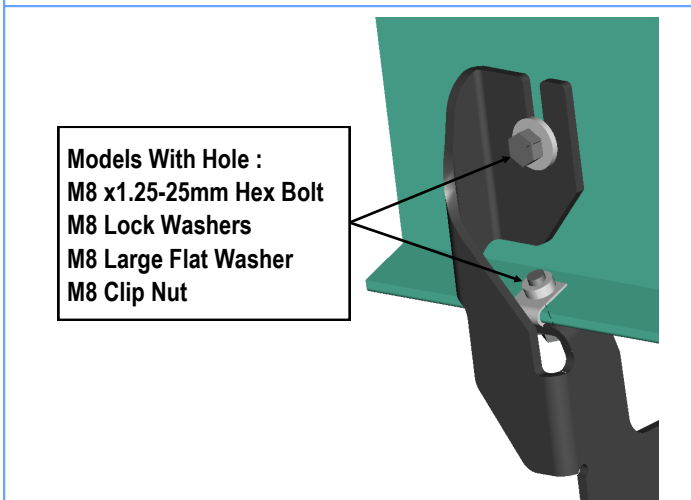

Models With Hole :  
M8 x1.25-25mm Hex Bolt  
M8 Lock Washers  
M8 Large Flat Washer  
M8 Clip Nut

(Fig 12) Passenger Front Mounting Bracket Installed

## STEP 8

Repeat **Steps 2—4** for the (2) remaining passenger side mounting brackets installations.

**2017-up 2500/3500 DEF tank models:** Locate the 2nd tab bracket location along the bottom edge of the body, (pinch weld), (Fig 14). Hold the DEF cover in place and mark the 2nd Bracket location onto the cover, (Fig 15). Use a sharp knife or hacksaw blade to carefully cut a slot in the plastic cover to clear the 2nd Bracket, (Fig 16). Remove as little plastic as possible.

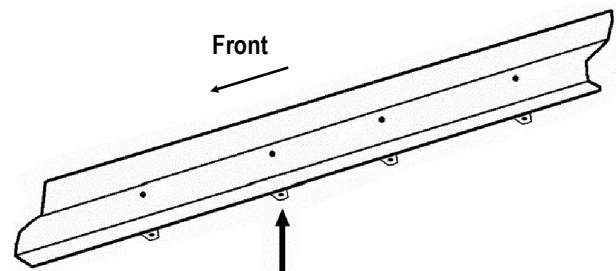

(Fig 14) Passenger 2nd Mounting Bracket Location From Back Of  
Body Panel

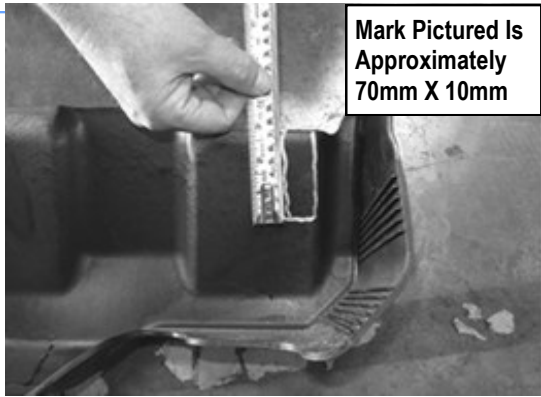

Mark Pictured Is  
Approximately  
70mm X 10mm

(Fig 15) 2017-Up Passenger Side DEF Cover Marked For Trimming

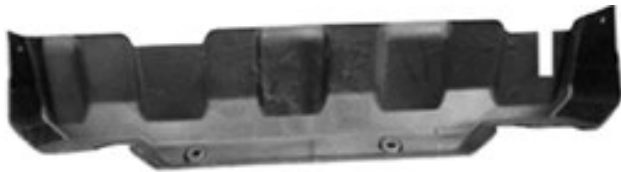

(Fig 16) 17-Up Passenger Side DEF Cut For Example Only

## STEP 9

Repeat **Step 5** to install the passenger side Step Bar installation.

## STEP 10

Once the Step Bar are installed and all hardware fully tightened, reinstall the DEF tank and cover, if equipped, as described in **Step 6**.

The installation is completed .

### Attention

Do periodic inspections to the installation to make sure that all hardware is secure and tight.

In order to protect your bars/boards, please use mild soap/non-abrasive products for cleaning only.