

iBoard®



Scan for
Installation Video

iBoard® by APS

PART#: IB-P905/P906Y&H

READ INSTRUCTIONS CAREFULLY BEFORE STARTING INSTALLATION. REMOVE CONTENTS FROM BOX AND VERIFY ALL PARTS ARE PRESENT. ASSISTANCE IS RECOMMENDED.

*ROCKER PANEL MOUNT
*NO DRILLING REQUIRED

Fastener Size	Tightening Torque (ft-lbs)	Required
6mm	6-7	√
8mm	16-18	√
10mm	31-32	X
12mm	56-58	X
14mm	92-94	X

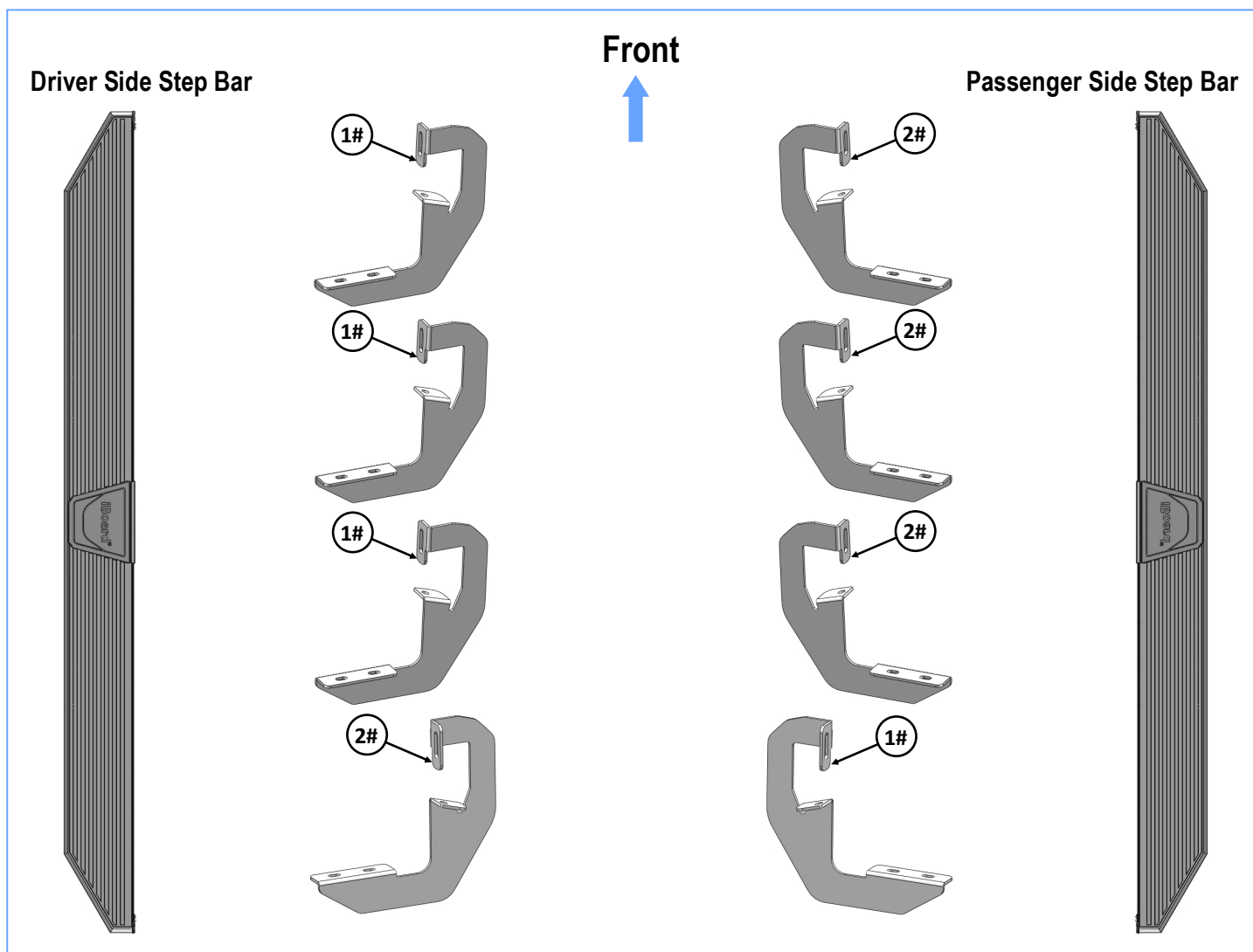

Customer Support: info@iboardauto.com



Hardware Package A (For Bracket Installation)

Item	QTY	Description	Item	QTY	Description
1#	4	Driver Front/Center1/Center2/Passenger Rear Brackets	4#	16	M8 Large Flat Washers
2#	4	Passenger Front/Center1/Center2/Driver Rear Brackets	5#	16	M8 Lock Washers
3#	16	M8X1.25-20mm Hex Bolts	6#	12	M8 Hex Nuts

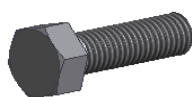

3 #



4 #



5 #



6 #

Hardware Package B (For Step Bar Installation)

Item	QTY	Description	Item	QTY	Description
1#	16	M8X1.25-35mm Carriage Bolts	3#	16	M8 Nylon Lock Nuts
2#	16	M8 Large Flat Washers	4#	8	Sliders (Packed with Mounting Brackets)

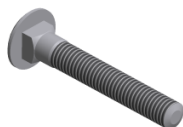

1 #



2 #

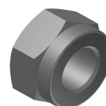

3 #



4 #



STEP 1

Starting on the driver side front of the vehicle. Attach Driver Front Mounting Bracket as shown, (Fig 1). Do not fully tighten hardware at this time.

Note: Driver Front/Center1/Center2/Passenger Rear Brackets are Universal.

STEP 2

Move to Driver side other 3 mounting locations. Repeat **Step 1** to install the Mounting Brackets. Do not fully tighten hardware at this time.

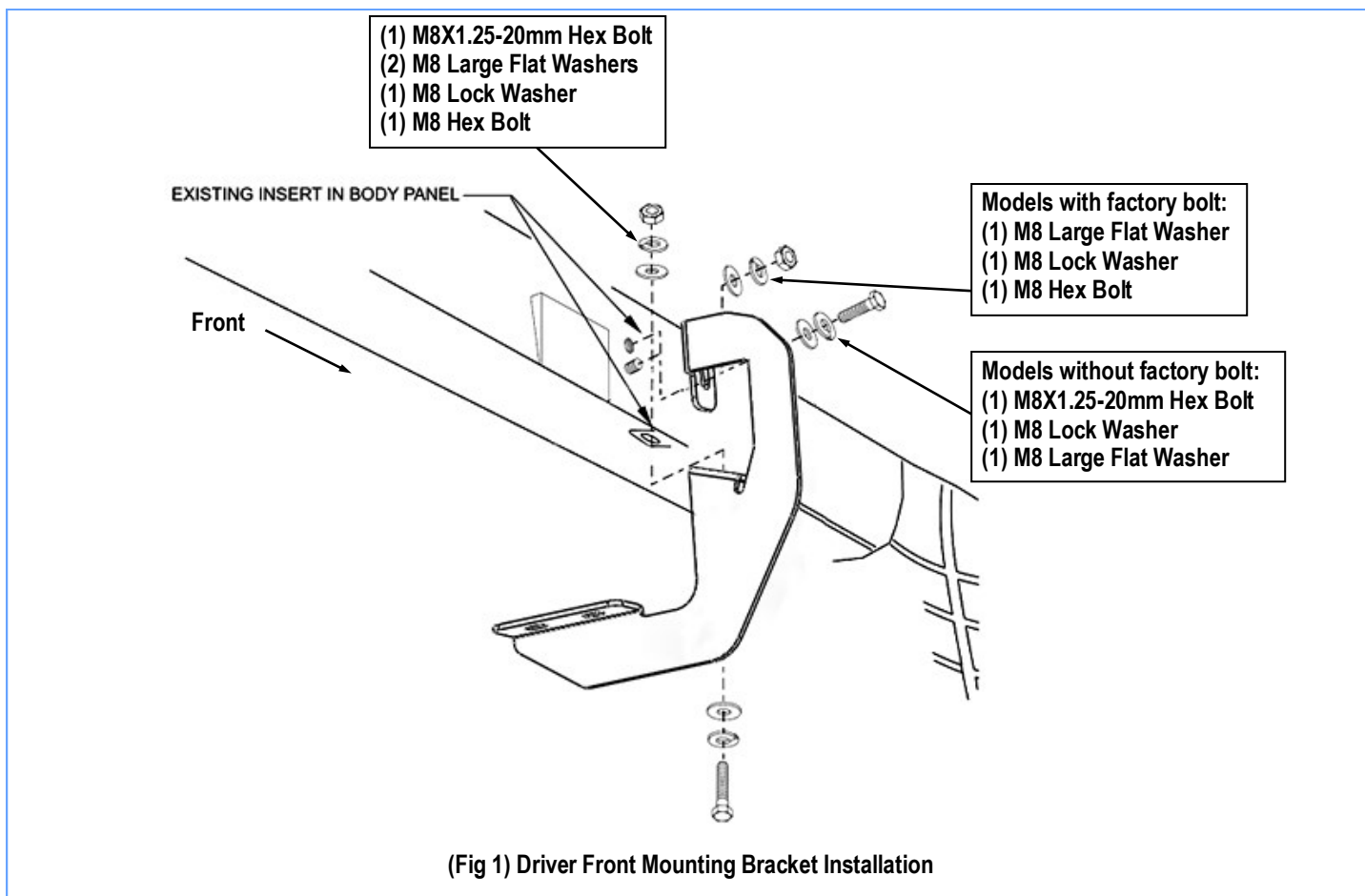



STEP 3

Once all (3) Driver side mounting brackets are installed, then proceed to the Step Bar installation. **(Figs 2 & 3)**

- (1) Select (1) Slider and (2) M8X1.25-35mm Carriage Bolts;
- (2) Install (2) M8X1.25-35mm Carriage Bolts in (1) Slider.
- (3) Slide the Slider (with carriage bolts) to the **Step Bar**.
- (4) Repeat to install the other (3) sliders to the step bar.
- (5) Attach the Step Bar (with the Sliders) onto the installed mounting brackets. Position the Sliders to the installed brackets. Secure the Step Bar to the installed Brackets by using (8) M8 Large Flat Washers and (8) M8 Nylon Lock Nuts and (4) Sliders, **(Fig 3)**. Do not fully tighten hardware at this time.

Note: The Sliders are packed with the Mounting Brackets.

Level and adjust the Step Bar and fully tighten all hardware.

Repeat **Steps 1-3** for the other side Step Bar installation. **The installation is completed!!!**

Attention

Do periodic inspections to the installation to make sure that all hardware is secure and tight.

In order to protect your bars/boards, please use mild soap/non-abrasive products for cleaning only.

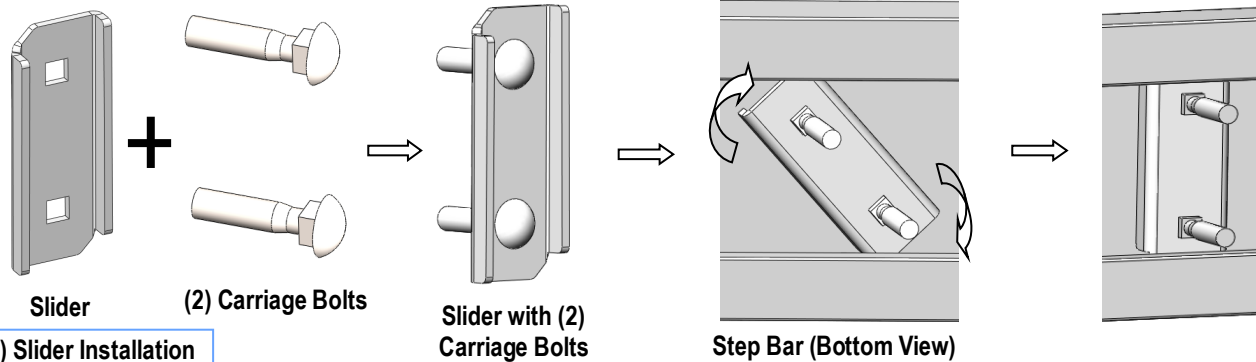

(Fig 2) Slider Installation

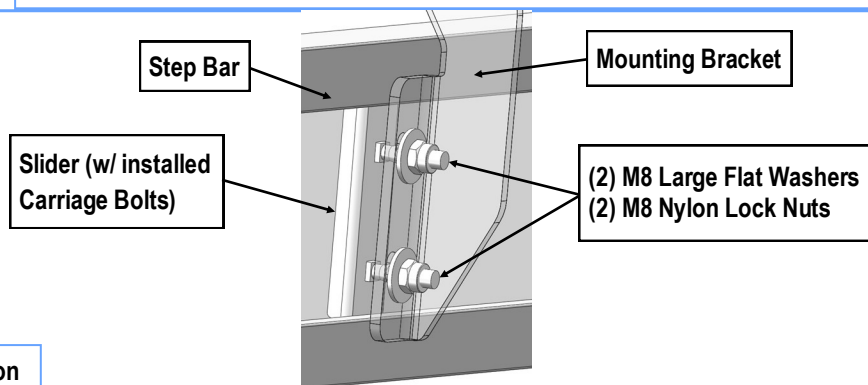

(Fig 3) Step Bar Installation