



PART#: IB-P233Y&H

iBoard® Series

READ INSTRUCTIONS CAREFULLY BEFORE START ING INSTALLATION. REMOVE CONTENTS FROM BOX AND VERIFY ALL PARTS ARE PRESENT. ASSISTANCE IS RECOMMENDED.

*ROCKER PANEL MOUNT
*NO DRILLING REQUIRED

Fastener Size	Tightening Torque (ft-lbs)	Required
6mm	6-7	X
8mm	16-18	√
10mm	31-32	√
12mm	56-58	X
14mm	92-94	X

PART LIST

Driver Side Step Bar

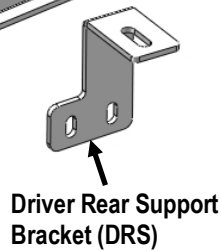
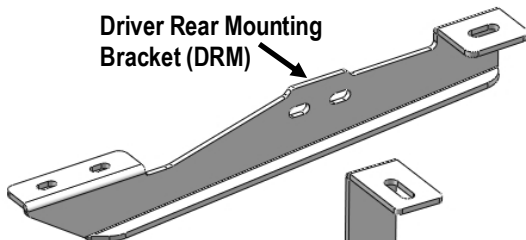
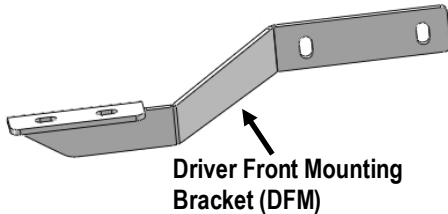
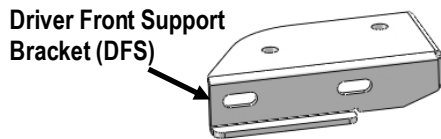

Front
↑



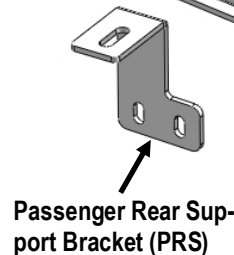
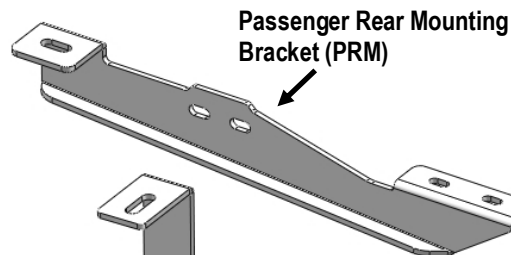
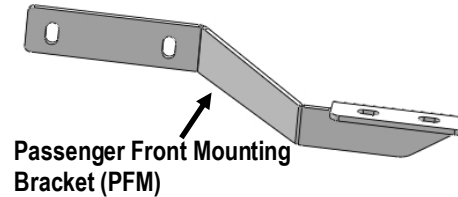
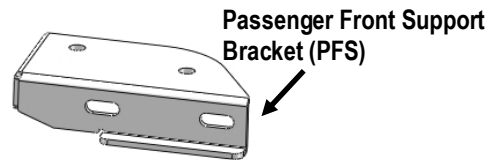
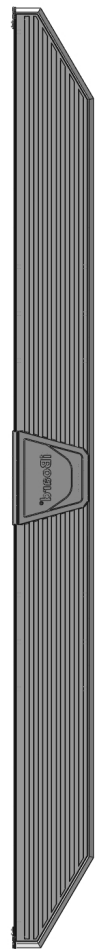

Passenger Side Step Bar





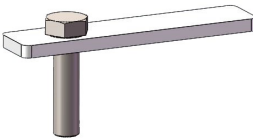
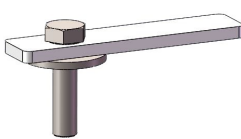
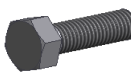



Scan for
Installation Video

Hardware Package A (For Bracket Installation)						
Item	QTY	Description	Item	QTY	Description	
1#	2	M10X45 Bolt Plates	5#	16	M10 Flat Washers	
2#	6	M10X40 Bolt Plates	6#	16	M10 Lock Washers	
3#	8	M10X1.5-30mm Hex Bolts	7#	16	M10 Hex Nuts	
4#	8	M10 Large Flat Washers				

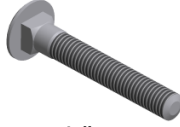
						
1#	2#	3#	4#	5#	6#	7#

Hardware Package B (For Step Bar Installation)						
Item	QTY	Description	Item	QTY	Description	
1#	8	M8X1.25-35mm Carriage Bolts	3#	8	M8 Nylon Lock Nuts	
2#	8	M8 Large Flat Washers	4#	4	Sliders (Packed with Mounting Brackets)	

			
1 #	2 #	3 #	4 #



STEP 1

Starting from the driver side front of the vehicle. Locate the (2) large factory holes in the floor panel by the front tires, **(Fig 1)**.

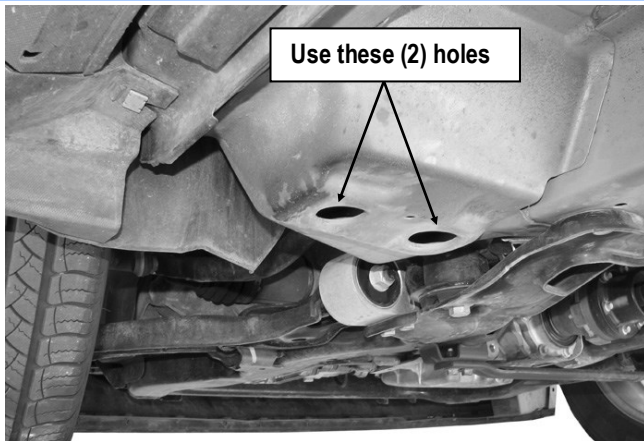

(Fig 1) Driver Side Front Mounting Location

STEP 2

Assemble Driver Front Mounting Bracket (**DFM**) and Driver Front Support Bracket (**DFS**) with (2) M10X1.5-30mm Hex Bolts, (4) M10 Flat Washers, (2) M10 Lock Washers and (2) M10 Hex Nuts, **(Fig 2)**. Do not fully tighten hardware at this time.

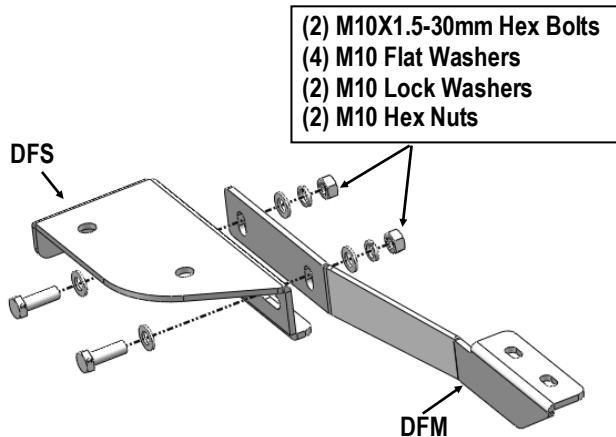

(Fig 2) Driver Side Front Brackets Assembly

STEP 3

Select (2) M10x40 Bolt Plates. Insert (1) M10x40 Bolt Plate into each of the factory holes, **(Fig 3A)**.

IMPORTANT: Once you have inserted the Bolt Plates, make sure that the welded washer on each Bolt Plate is in the center of the factory hole. **(Figs 3A & 3B)**.

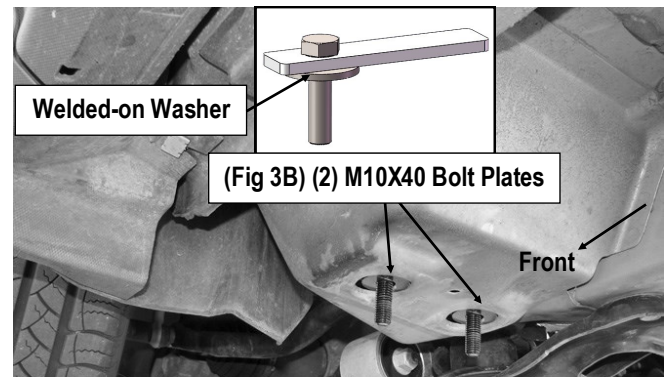

**(Fig 3A) (2) M10x40 Bolt Plates Installed
(On Driver Side Front Mounting Location)**

STEP 4

Attach the Assembled Driver Front Mounting Bracket (**DFM**) to the installed (2) M10x40 Bolt Plates with (2) M10 Large Flat Washers, (2) M10 Lock Washers and (2) M10 Hex Nuts, **(Fig 4)**.

NOTE: Make sure that the welded-on washers are fully seated in the large openings on the floor before tightening hardware. Do not fully tighten hardware at this time.

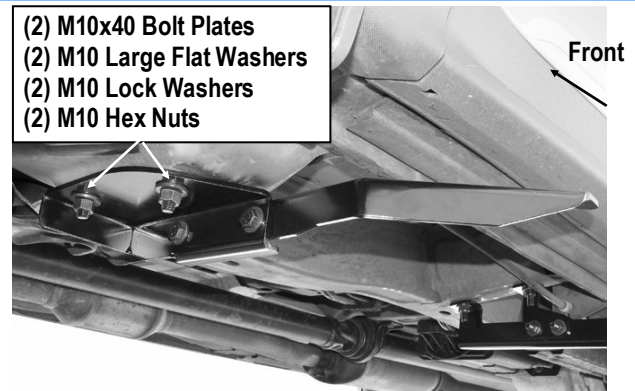

(Fig 4) Driver Side Front Brackets Installed



STEP 5

Move to the Driver side rear mounting location, **(Fig 5)**. Locate the (2) large factory holes at the bottom of the frame channel.

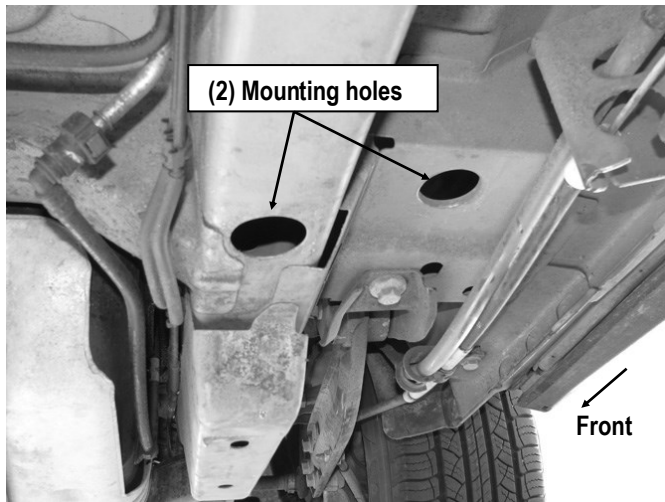

(Fig 5) Driver Side Rear Mounting Location

STEP 6

Repeat **Step 2** to assemble Driver Rear Mounting Bracket **(DRM)** and Driver Rear Support Bracket **(DRS)**, **(Fig 6)**. Do not fully tighten hardware at this time.

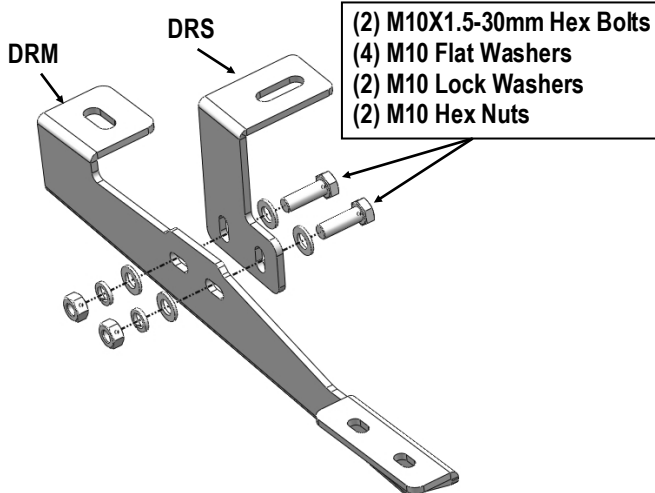

(Fig 6) Driver Side Rear Brackets Assembly

STEP 7

Insert (1) M10x40 Bolt Plate into the large hole in the suspension mount as described in **Step 3**, **(Figs 7A & 7B)**. Next, locate the factory hole in the bottom of the inner frame channel. Insert (1) M10x45 Bolt Plate, (no welded washer), into the hole in the bottom of the frame channel, **(Figs 8A & 8B)**.

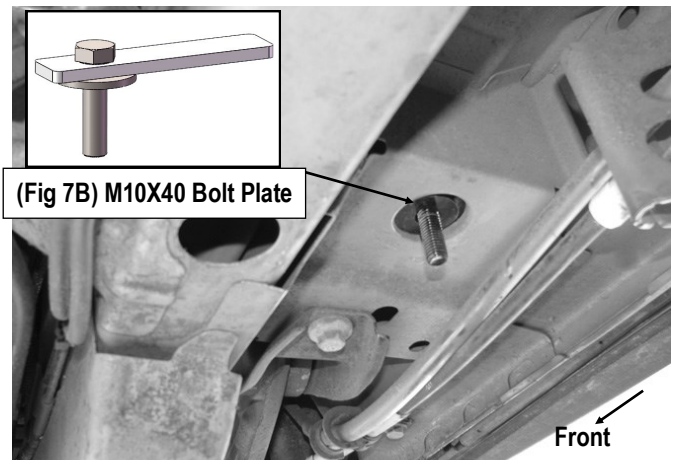

**(Fig 7A) M10X40 Bolt Plate Installed
(On Driver Side Rear Mounting Location)**

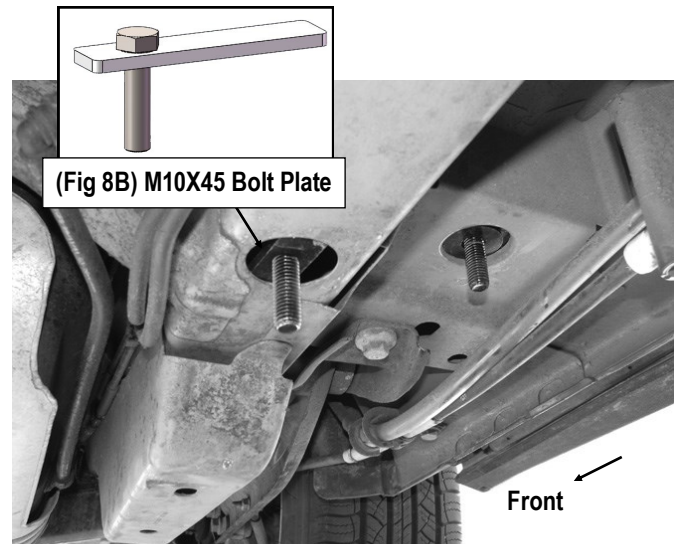

**(Fig 8A) M10x45 Bolt Plate Installed
(On Driver Side Rear Mounting Location)**



STEP 8

Attach the assembled Driver Rear Mounting Bracket (**DRM**) to the installed (2) M10 Bolt Plates with (2) M10 Large Flat Washers, (2) M10 Lock Washers and (2) M10 Hex Nuts. (**Fig 9**). Do not fully tighten hardware at this time.

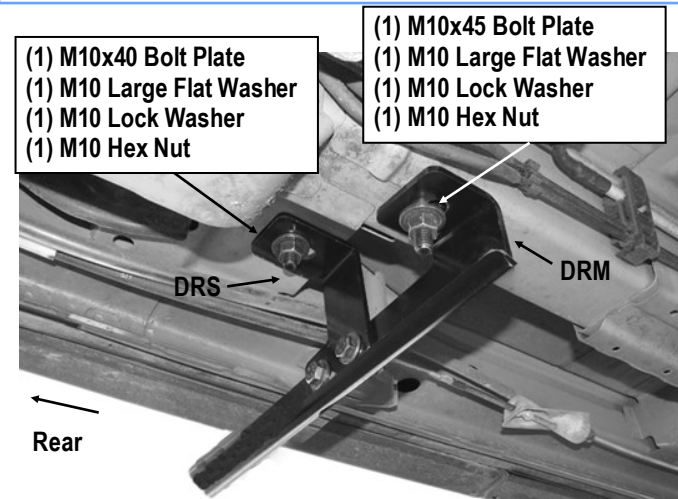

(Fig 9) Driver Side Rear Brackets Installed

STEP 9

Once all (2) Driver side mounting brackets are installed, then proceed to the Step Bar installation. (**Figs 10 & 11**)

- (1) Select (1) Slider and (2) M8X1.25-35mm Carriage Bolts;
- (2) Install (2) M8X1.25-35mm Carriage Bolts in (1) Slider.
- (3) Slide the Slider (with carriage bolts) to the **Step Bar**.
- (4) Repeat to install the other (1) slider to the step bar.
- (5) Attach the Step Bar (with the Sliders) onto the installed mounting brackets. Position the Sliders to the installed brackets. Secure the Step Bar to the installed Brackets by using (4) M8 Large Flat Washers and (4) M8 Nylon Lock Nuts and (2) Sliders, (**Fig 11**). Do not fully tighten hardware at this time.

Note: The Sliders are packed with the Mounting Brackets.

Level and adjust the Step Bar and fully tighten all hardware.

Repeat **Steps 1-9** for the other side Step Bar installation. **The installation is completed!!!**

Attention

Do periodic inspections to the installation to make sure that all hardware is secure and tight.

In order to protect your bars/boards, please use mild soap/non-abrasive products for cleaning only.

