

iArmor[®]

IARMOR EDGE™

PART#: IA-N060H

BEFORE INSTALLATION

REMOVE CONTENTS FROM BOX. VERIFY ALL PARTS ARE PRESENT. READ INSTRUCTIONS CAREFULLY BEFORE STARTING INSTALLATION. ASSISTANCE IS RECOMMENDED. THANK YOU FOR CHOOSING OUR PRODUCT!

*ROCKER PANEL MOUNT

*DRILLING IS REQUIRED

Torque Value

Fastener Size	Tightening Torque (ft-lbs)	Required
6mm	6-7	√
8mm	16-18	√
10mm	31-32	X
12mm	56-58	X
14mm	92-94	X

PART LIST

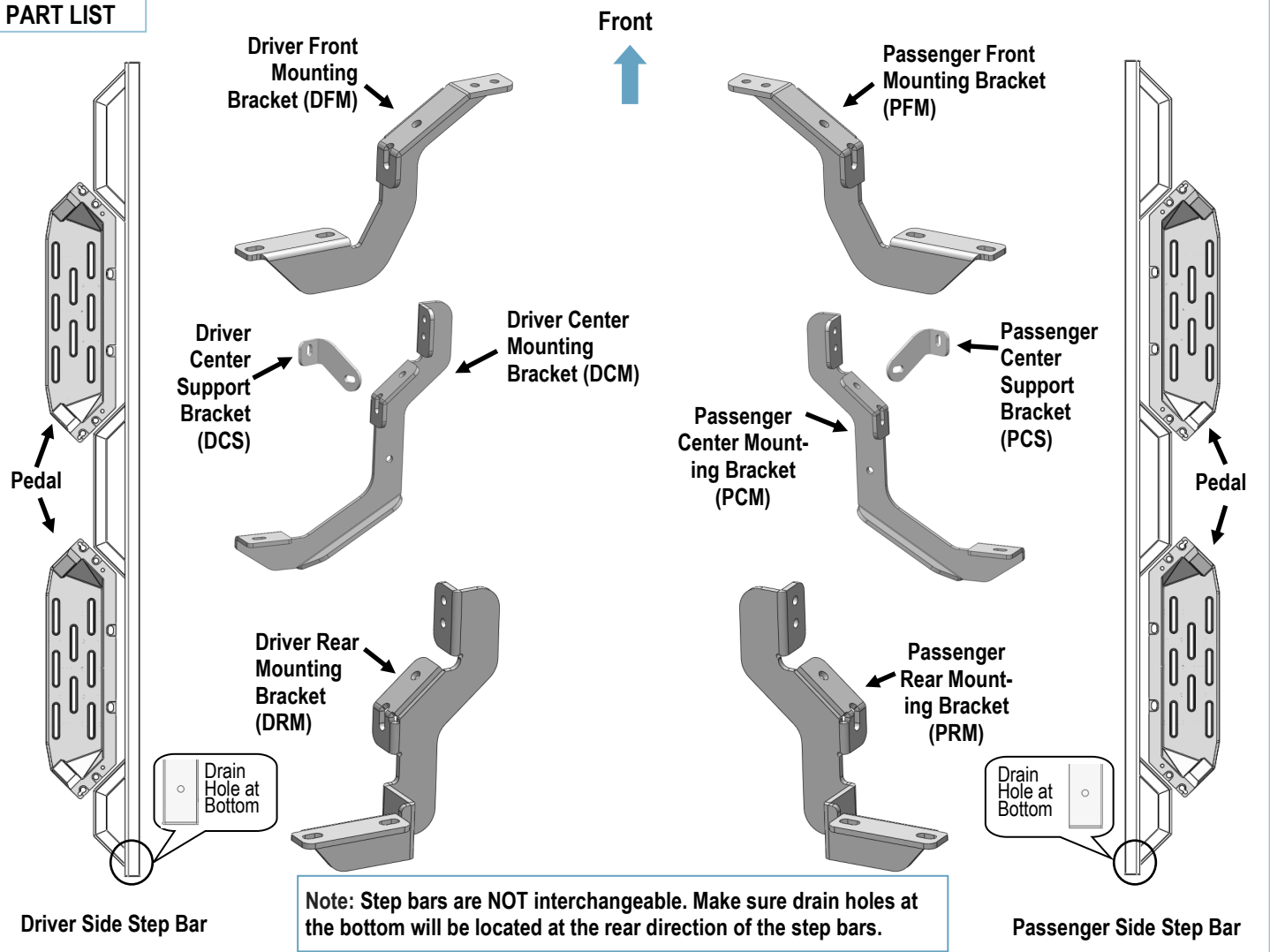

Customer Support: info@iarmorauto.com

iArmor[®]

Hardware Package A (For Brackets & Bars Installation)					
Item	QTY	Description	Item	QTY	Description
1#	2	M8X1.25-25mm Hex Bolts	6#	2	M6X1-20 Square Head Bolts
2#	6	M8X1.25-20mm Hex Bolts	7#	2	M6 Large Flat Washers
3#	26	M8 Large Flat Washers	8#	2	M6X1 Nylon Lock Nuts
4#	18	M8 Nylon Lock Nuts	9#	10	M8X1.25-20 T-Bolts
5#	12	ST6.3X25mm Hex Self Tapping Screws	10#	10	M8 Plastic Washers

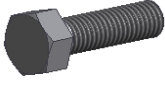

1 #

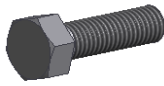

2 #



3 #



4 #

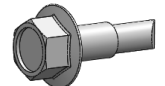

5 #

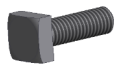

6 #



7 #



8 #



9 #



10 #

Hardware Package B (For Step Pedals Installation)					
Item	QTY	Description	Item	QTY	Description
1#	24	M8X1.25-25 Hex Bolts	3#	24	M8 Lock Washers
2#	24	M8 Large Flat Washers			

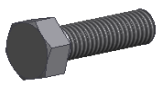

1#



2#



3#

Customer Support: info@iarmorauto.com

iArmor®

The instruction here is for your reference only. We strongly recommend the professional installer for best result. We are not responsible for any damage caused by the installation.

STEP 1

Install (4) Pedals onto the step bars with (24) M8X1.25-25mm Hex Bolts, (24) M8 Large Flat Washers and (24) M8 Lock Washers.

IMPORTANT: Don't punch the pedal with any metal hammer within pedal installation, or the pedal will be damaged.

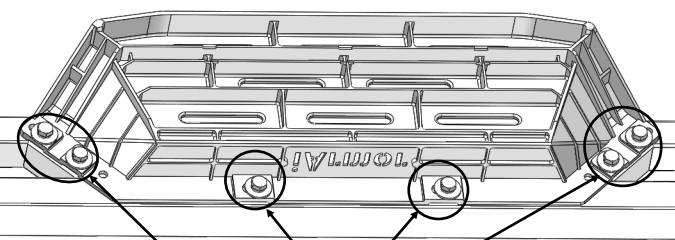

- (6) M8X1.25-25 Hex Bolts
- (6) M8 Large Flat Washers
- (6) M8 Lock Washers

STEP 2

Start installation from the Driver Side of the vehicle. Mark the (3) driver side mounting locations on pinch weld as shown on Fig 1.

Note: make sure the (3) brackets are on the same level and then mark the hole locations on the pinch weld.

Drill (3) 5/16" holes on the pinch weld according to the marked locations, (Fig 1).

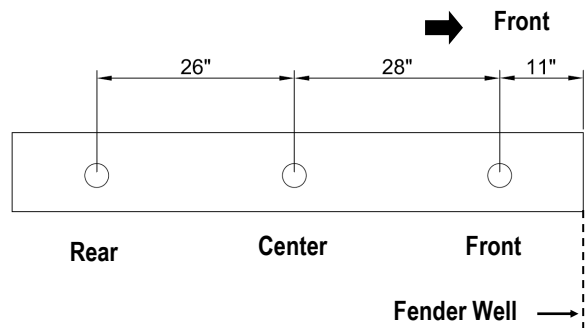

(Fig 1) Driver Side Mounting Locations (on Pinch Weld)

STEP 3

Using (1) M8X1.25-20mm Hex Bolt, (2) M8 Large Flat Washers and (1) M8X1.25 Nylon Lock Nut, attach the Driver Front Mounting Bracket (DFM) to the previously drilled hole on Pinch Weld on STEP 2. And then secure the bracket onto the frame rail with (2) ST6.3X25mm Self Tapping screws, (Fig 2).

Note: 1/5" holes may be required to drill on the frame rail on some models.

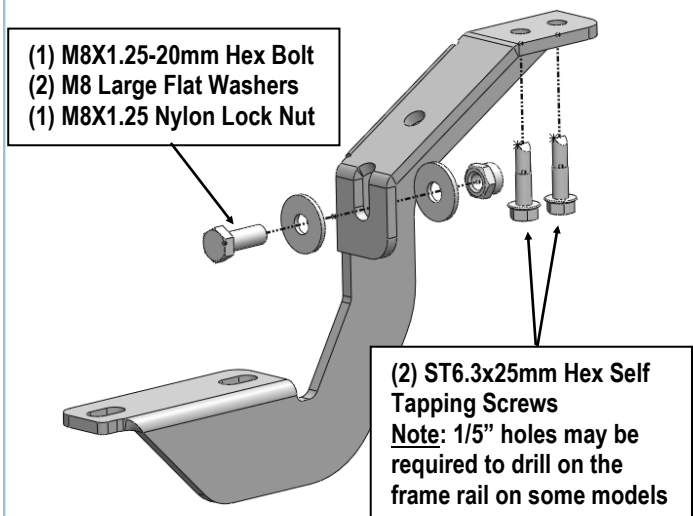

(Fig 2) Driver Front Mounting Bracket Installation

iArmor®

STEP 4

Move to the driver side center mounting location, (Fig 1). Assemble Driver Center Mounting Bracket (DCM) and Driver Center Support Bracket (DCS) with (1) M8X1.25-25mm Hex Bolt, (2) M8 Large Flat Washers and (1) M8X1.25 Nylon Lock Nut, (Fig 3). Do not fully tighten hardware at this time. Repeat STEP 3 for the Driver Center Mounting Bracket installation.

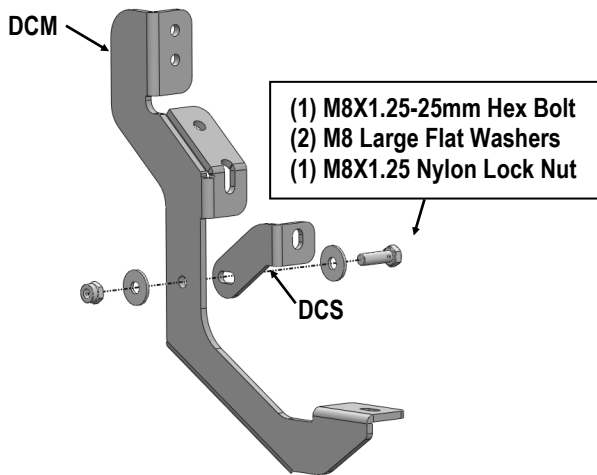

(Fig 3) Driver Center Brackets Assembly

STEP 5

Move to the driver side rear mounting location of the vehicle, (Fig 1). Repeat STEP 3 for Driver Rear Mounting Bracket installation.

STEP 6

Once all (3) brackets have been installed, select (5) M8X1.25-20mm T-Bolts, thread (1) M8 Plastic Washer on each T-Bolt, (Fig 4). Install the (5) M8X1.25-20mm T-Bolts with plastic washers in the slots on the assembled Driver side step bar. Rotate the T-Bolts to 90 degree, thread down the M8 Plastic Washers against the step bar (Fig 5).

NOTE: The Plastic Washer is designed to keep the T-Bolt in place to avoid falling into the tube during installation.

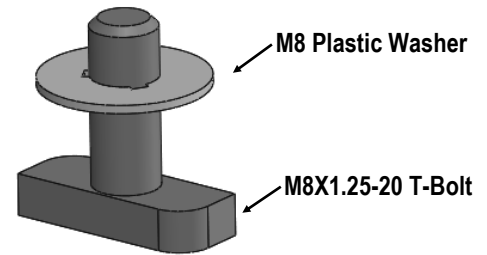

(Fig 4) Thread (1) M8 Plastic Washer on each T-Bolt Before Inserting into the slot !!!

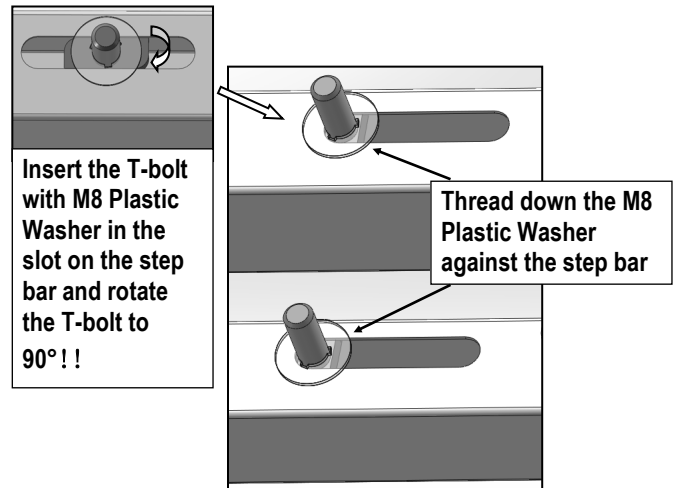

(Fig 5) T-Bolt with plastic washer in the slot

STEP 7

Attach the Assembled Driver Side Step Bar onto the Mounting Brackets with (5) M8 Plastic Washers, (5) M8X1.25-20mm T-Bolts, (5) M8 Large Flat Washers, (5) M8 Nylon Lock Nuts, (Fig 6). Do not fully tighten hardware at this time.

NOTE: Driver Center Mounting Bracket is located under the front pedal. Slide (1) M6X1-20mm Square Head Bolt into the channel at the bottom of front pedal (Fig 7). And secure the Driver Center Mounting Bracket to the pedal with (1) M6 Large Flat Washer and (1) M6 Nylon Lock Nut, (Fig 6). Do not fully tighten hardware at this time.

iArmor®

STEP 8

Level and adjust the assembled Step Bar properly and tighten all hardware.

Move to the other side of the vehicle. Repeat **Steps 2-7** for the other Side Step Bar installation.

Attention

Do periodic inspections to the installation to make sure that all hardware is secure and tight.

In order to protect your bars/boards, please use mild soap/non-abrasive products for cleaning only.

