

# iArmor<sup>®</sup>

## IARMOR EDGE™

PART#: IA-N050H

### BEFORE INSTALLATION

REMOVE CONTENTS FROM BOX. VERIFY ALL PARTS ARE PRESENT. READ INSTRUCTIONS CAREFULLY BEFORE STARTING INSTALLATION. ASSISTANCE IS RECOMMENDED. THANK YOU FOR CHOOSING OUR PRODUCT!

\*ROCKER PANEL MOUNT

\*DRILLING NOT REQUIRED

### Torque Value

Fastener Size	Tightening Torque (ft-lbs)	Required
6mm	6-7	X
8mm	16-18	√
10mm	31-32	X
12mm	56-58	X
14mm	92-94	X

### PART LIST

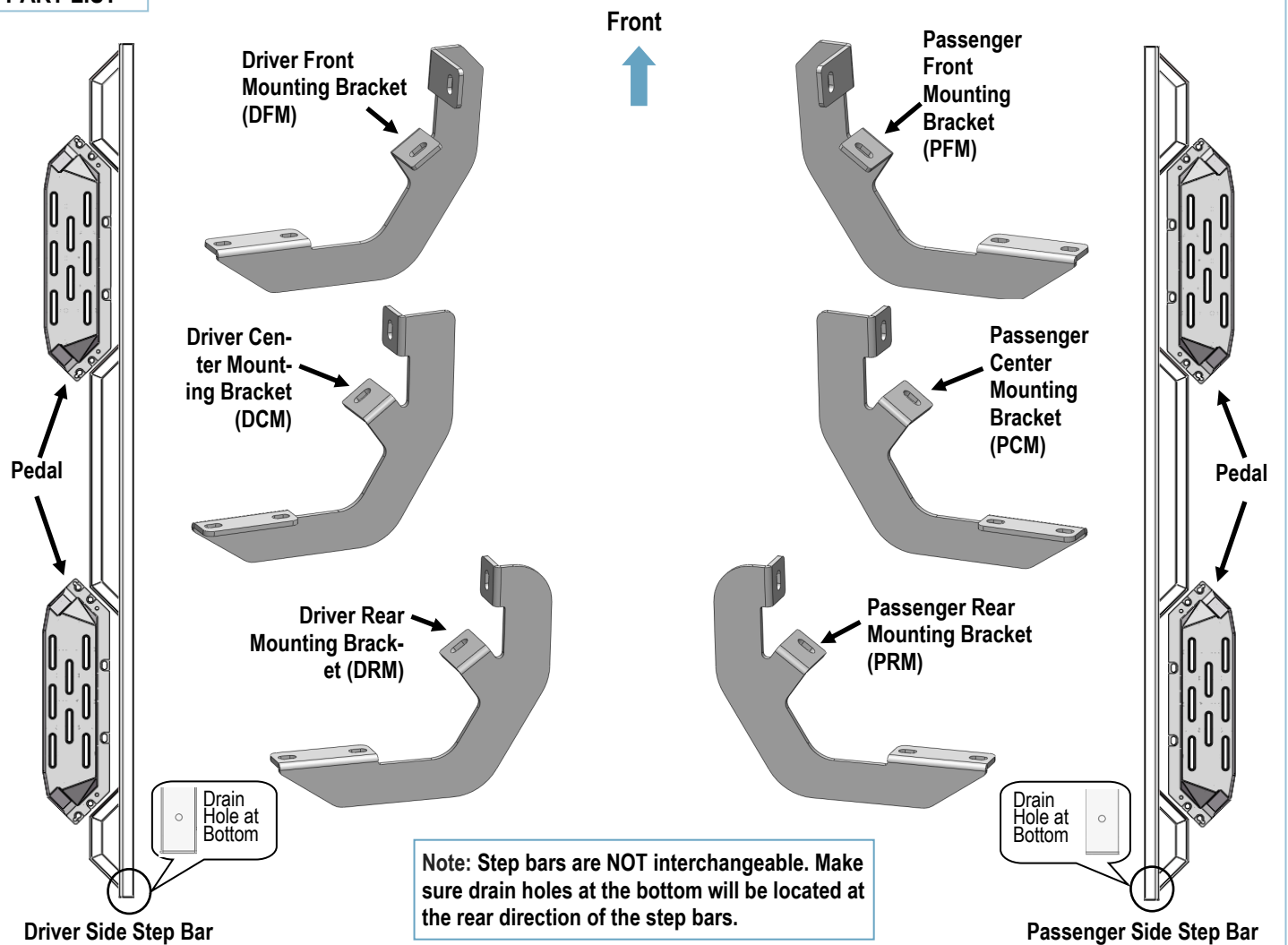





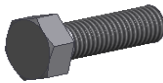

Customer Support: [info@iarmorauto.com](mailto:info@iarmorauto.com)

# iArmor<sup>®</sup>



Hardware Package A (For Brackets & Bars Installation)					
Item	QTY	Description	Item	QTY	Description
1#	12	M8X1.25-30mm Hex Bolts	4#	18	M8 Nylon Lock Nuts
2#	24	M8 Large Flat Washers	5#	12	M8X1.25-20 T-Bolts
3#	12	M8 Lock Washers	6#	12	M8 Plastic Washers

					
1 #	2 #	3 #	4 #	5 #	6 #

Hardware Package B (For Step Pedals Installation)					
Item	QTY	Description	Item	QTY	Description
1#	24	M8X1.25-25 Hex Bolts	3#	24	M8 Lock Washers
2#	24	M8 Large Flat Washers			

		
1#	2#	3#

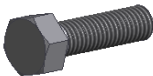
Customer Support: [info@iarmorauto.com](mailto:info@iarmorauto.com)

# iArmor®

The instruction here is for your reference only. We strongly recommend the professional installer for best result. We are not responsible for any damage caused by the installation.

## STEP 1

Install (4) Pedals onto the step bars with (24) M8X1.25-25mm Hex Bolts, (24) M8 Large Flat Washers and (24) M8 Lock Washers.

**IMPORTANT:** Don't punch the pedal with any metal hammer within pedal installation, or the pedal will be damaged.

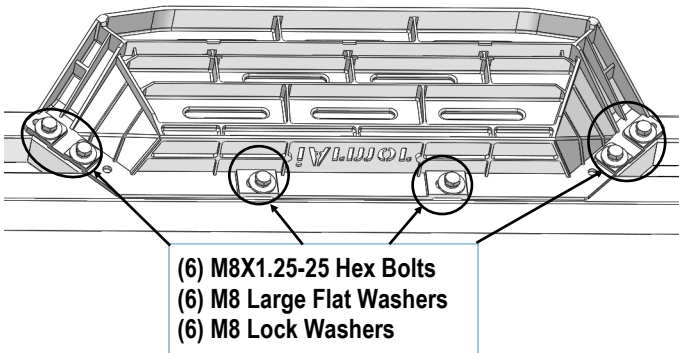

## STEP 2

Start installation at the front of the driver side of the vehicle and locate the factory threaded holes or stud located on the side of the inner body panel, (Figs 1 & 2). **NOTE:** Remove the plastic plug or any insulation on the side panel to locate the threaded holes.

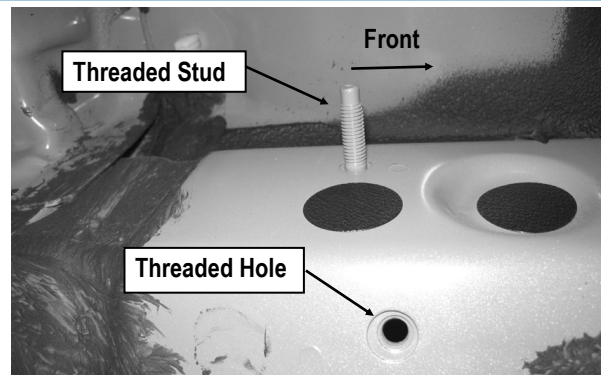

(Fig 1) Up To 2015 Driver Side Rear Mounting Location  
Note: Remove Plastic Plugs To Locate Factory Threaded Hole

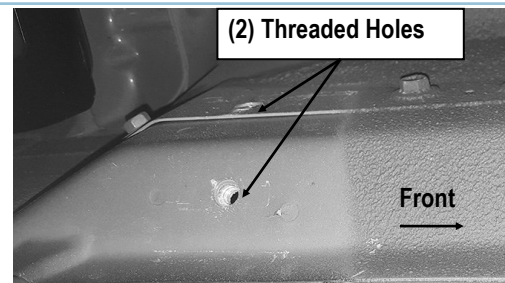

(Fig 2) 2016-UP Driver Side Rear Mounting Location  
Note: Two Factory Threaded Holes Only

## STEP 3

Attach (1) Driver Front Mounting Bracket (DFM) onto the Driver Side Front Mounting Location as shown (Fig 3).

- Models with threaded stud:** Attach the Mounting Bracket to upper stud with (1) M8 Flat Washer and (1) M8 Nylon Lock Nut. Next, secure the bracket to the lower threaded hole with (1) M8X1.25-30 Hex Bolt, (1) M8 Large Flat Washer and (1) M8 Lock Washer. Do not tighten hardware at this time.
- Models without threaded stud:** Attach the Mounting Bracket to the upper threaded hole with (1) M8X1.25-30 Hex Bolt, (1) M8 Large Flat Washer and (1) M8 Lock Washer. Next, secure the bracket to the lower threaded hole with (1) M8X1.25-30 Hex Bolt, (1) M8 Flat Washer and (1) M8 Lock Washer. Do not fully tighten hardware at this time.

Repeat to Install the Driver Center and Rear Mounting Brackets.

# iArmor®

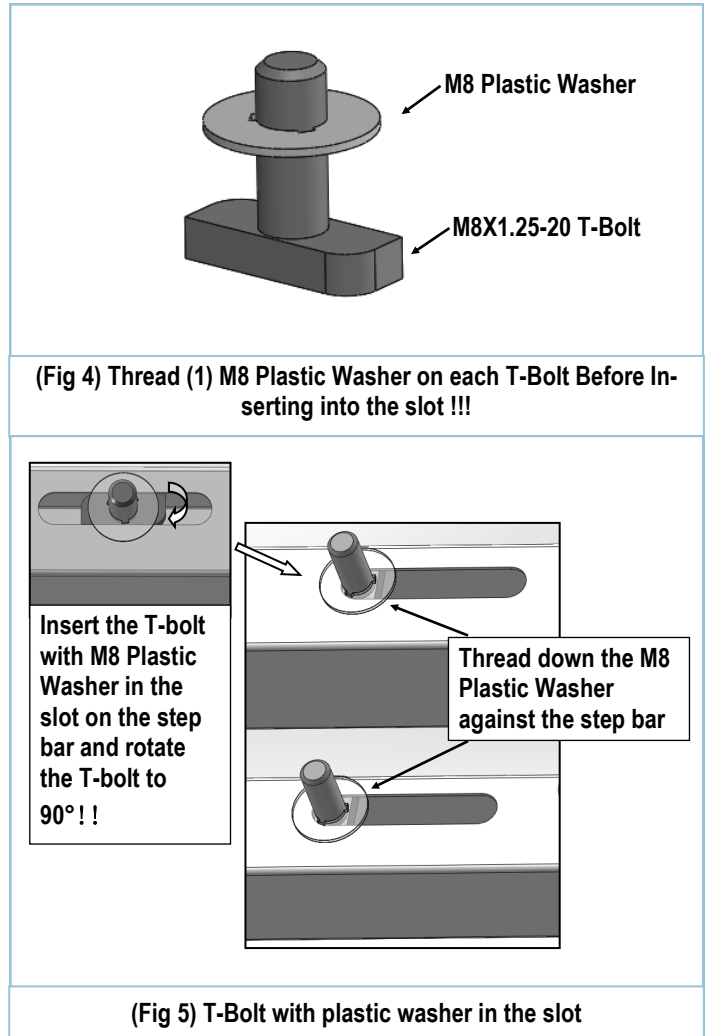
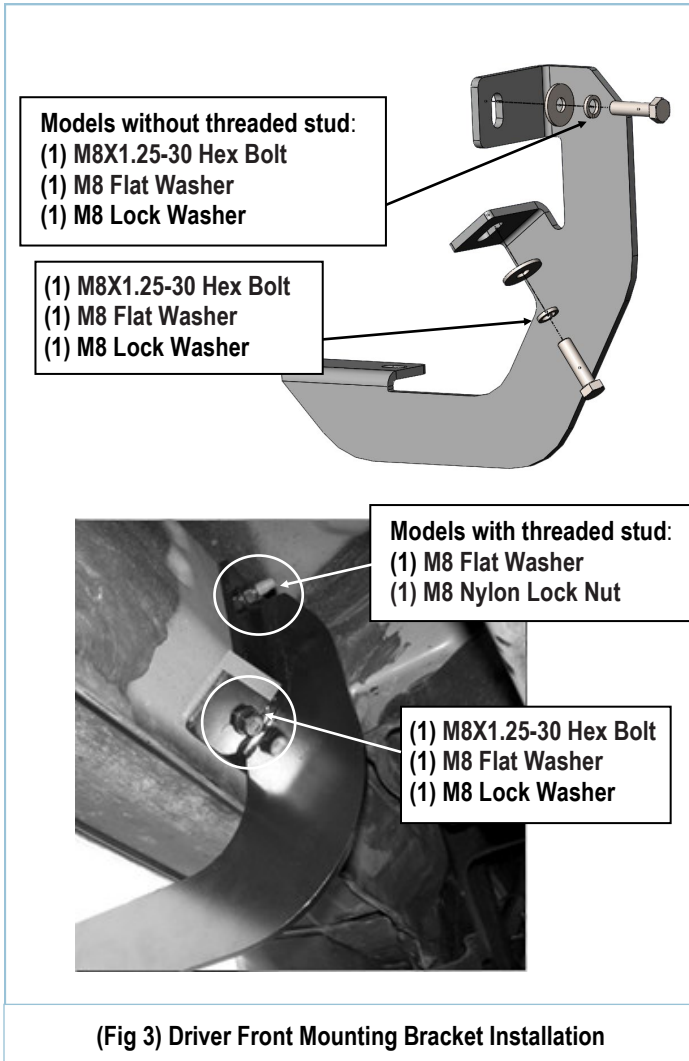

## STEP 4

Once all (3) brackets have been installed, select (6) M8X1.25-20mm T-Bolts, thread (1) M8 Plastic Washer on each T-Bolt, (Fig 4). Install the (6) M8X1.25-20mm T-Bolts with plastic washers in the slots on the assembled Driver side step bar. Rotate the T-Bolts to 90 degree, thread down the M8 Plastic Washers against the step bar (Fig 5).

**NOTE:** The Plastic Washer is designed to keep the T-Bolt in place to avoid falling into the tube during installation.

## STEP 5

Attach the Assembled Driver Side Step Bar onto the Mounting Brackets with (6) M8 Plastic Washers, (6) M8X1.25-20mm T-Bolts, (6) M8 Large Flat Washers, (6) M8 Nylon Lock Nuts, (Fig 6). Do not fully tighten hardware at this time.

# iArmor®

## STEP 6

Level and adjust the assembled Step Bar properly and tighten all hardware.

Move to the other side of the vehicle. Repeat **Steps 2-5** for the other Side Step Bar installation.

### Attention

Do periodic inspections to the installation to make sure that all hardware is secure and tight.

In order to protect your bars/boards, please use mild soap/non-abrasive products for cleaning only.

