

iArmor®

IARMOR EDGE™

PART#: IA-N106H

BEFORE INSTALLATION

REMOVE CONTENTS FROM BOX. VERIFY ALL PARTS ARE PRESENT. READ INSTRUCTIONS CAREFULLY BEFORE STARTING INSTALLATION. ASSISTANCE IS RECOMMENDED. THANK YOU FOR CHOOSING OUR PRODUCT!

*ROCKER PANEL MOUNT

*DRILLING NOT REQUIRED

Torque Value

Fastener Size	Tightening Torque (ft-lbs)	Required
6mm	6-7	√
8mm	16-18	√
10mm	31-32	X
12mm	56-58	X
14mm	92-94	X

PART LIST

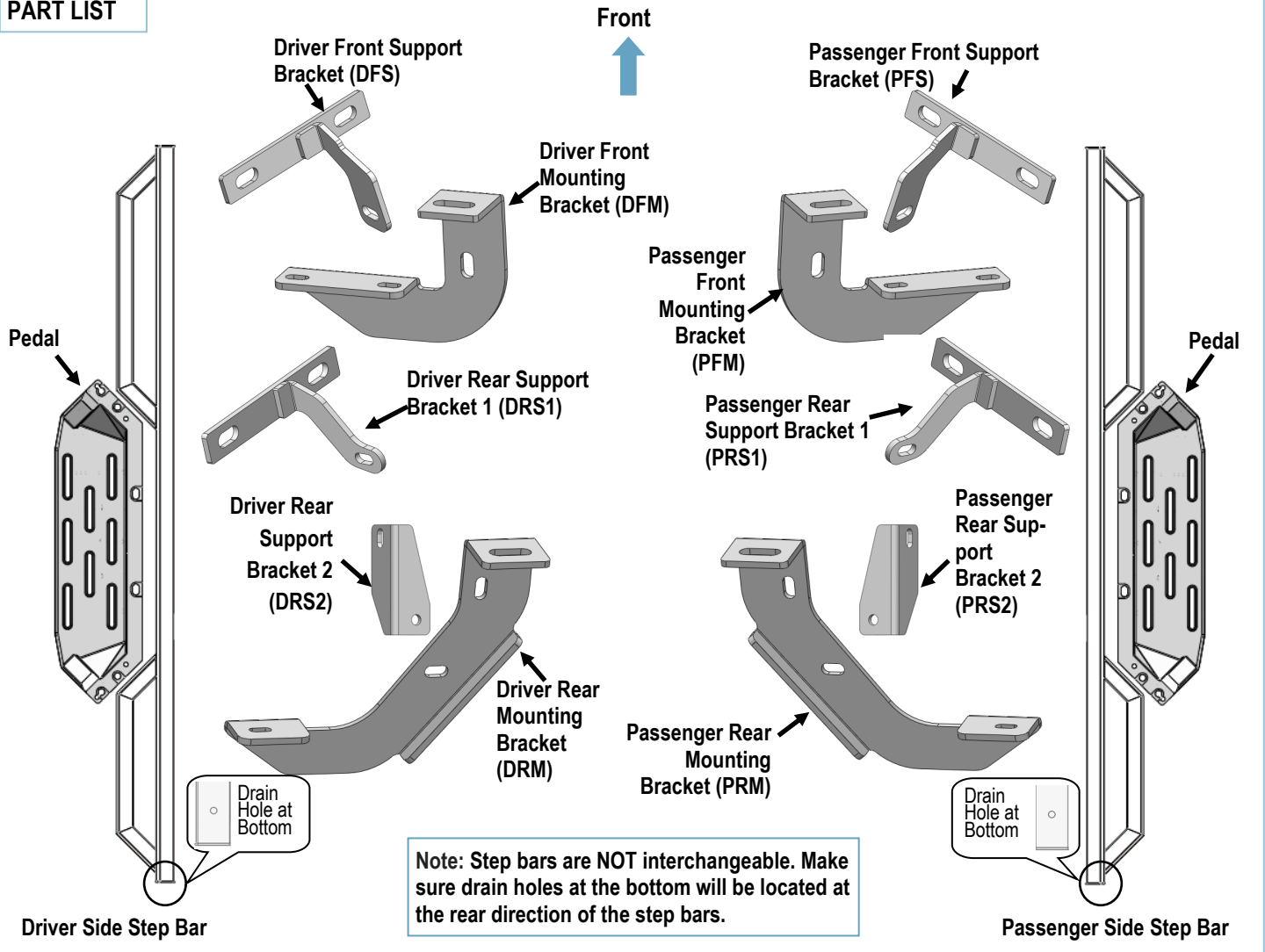



Customer Support: info@iarmorauto.com

iArmor®

Hardware Package A (For Brackets & Bars Installation)					
Item	QTY	Description	Item	QTY	Description
1#	4	M8X1.25 Nut Plate	7#	8	M6X1-25 Hex Bolts
2#	10	M8X1.25-35 Hex Bolts	8#	18	M6 Large Flat Washers
3#	4	M8 Large Flat Washers	9#	10	M6X1 Nylon Lock Nuts
4#	18	M8 Flat Washers	10#	2	M6X1-20 Square Head Bolts
5#	4	M8 Lock Washers	11#	6	M8X1.25-20 T-Bolts
6#	12	M8 Nylon Lock Nuts	12#	6	M8 Plastic Washers

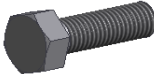

1 #



2 #



3 #

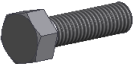

4 #



5 #



6 #

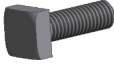

7 #

8 #



9 #



10 #

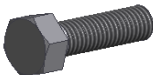

11 #

12 #

Hardware Package B (For Step Pedals Installation)					
Item	QTY	Description	Item	QTY	Description
1#	12	M8X1.25-25 Hex Bolts	3#	12	M8 Lock Washers
2#	12	M8 Large Flat Washers			

1#

2#

3#

Customer Support: info@iarmorauto.com

iArmor[®]

The instruction here is for your reference only. We strongly recommend the professional installer for best result. We are not responsible for any damage caused by the installation.

STEP 1

Install (2) Pedals onto the step bars with (12) M8X1.25-25mm Hex Bolts, (12) M8 Large Flat Washers and (12) M8 Lock Washers.

IMPORTANT: Don't punch the pedal with any metal hammer within pedal installation, or the pedal will be damaged.

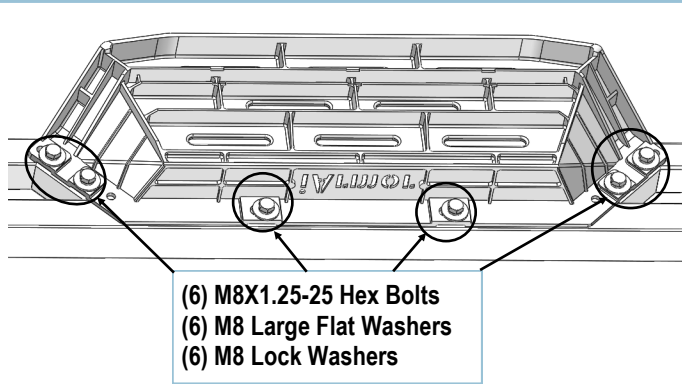

STEP 2

Start installation from the passenger front side of the vehicle. Determine if the vehicle has an open floor panel or a threaded hole in the floor panel:

A. Vehicles with open mounting location:

a. Insert (1) M8X1.25 Nut Plate into the large square opening in the floor panel. Line up the threaded nut with the hole located between the pair of holes on the pinch weld, (Fig 1A, 1B & 2).

b. Move to the Passenger Side Rear Mounting Location, (Fig 3). Repeat **Step 2a** to insert the M8X1.25 Nut Plate into the rear opening on the floor panel.

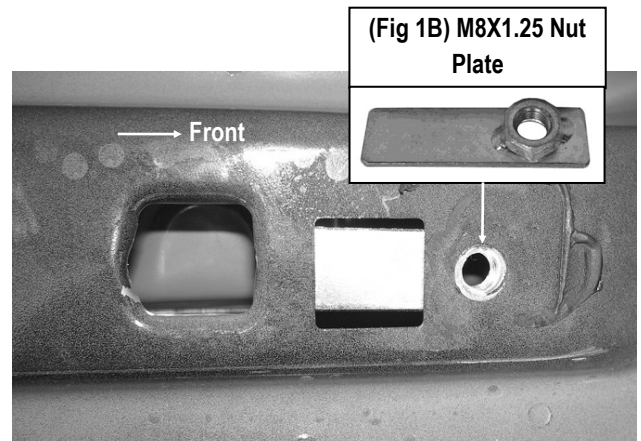

(Fig 1A) Passenger Side Front Mounting Location (Vehicles with open mounting location)

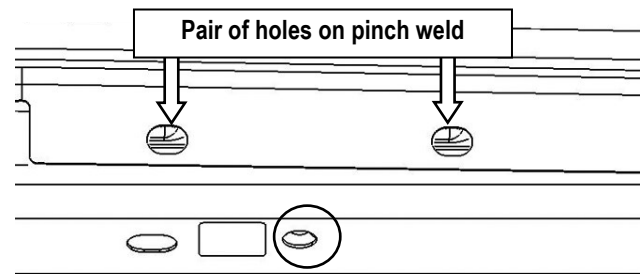

(Fig 2) Line up Nut Plate with hole located between the (2) holes on the pinch weld

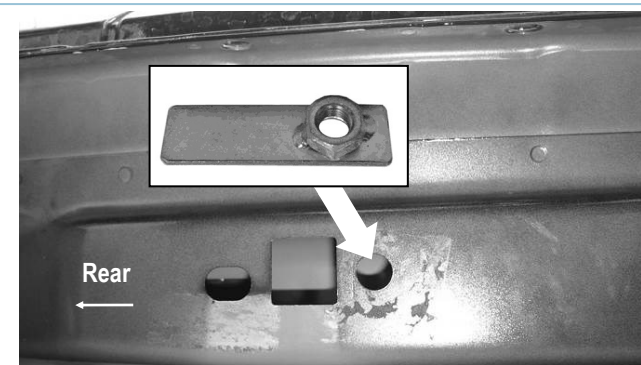

(Fig 3) Passenger Side Rear Mounting Location (Vehicles with open mounting location)

B. Vehicles with factory threaded hole in floor panel: Locate the passenger side front and rear mounting locations, (Figs 4 & 5). Continue to **Step 3**.

iArmor®

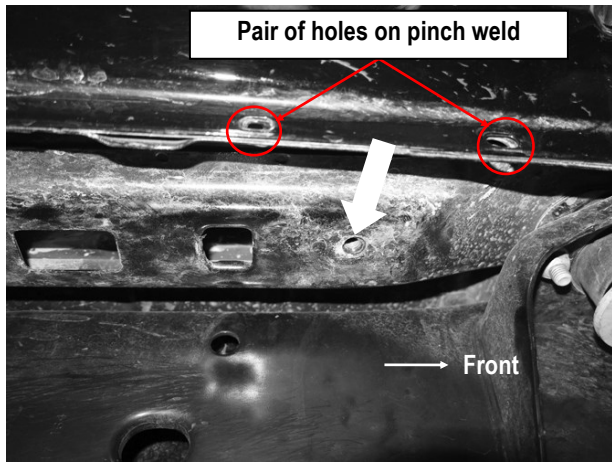

(Fig 4) Passenger Side Front Mounting Location
(Vehicles with factory threaded hole in floor panel)



(Fig 5) Passenger Side Rear Mounting Location
(Vehicles with factory threaded hole in floor panel)

STEP 3

Assemble Passenger Front Mounting Bracket (PFM) and Passenger Front Support Bracket (PFS) as shown, (Fig 6). Do not fully tighten hardware at this time.

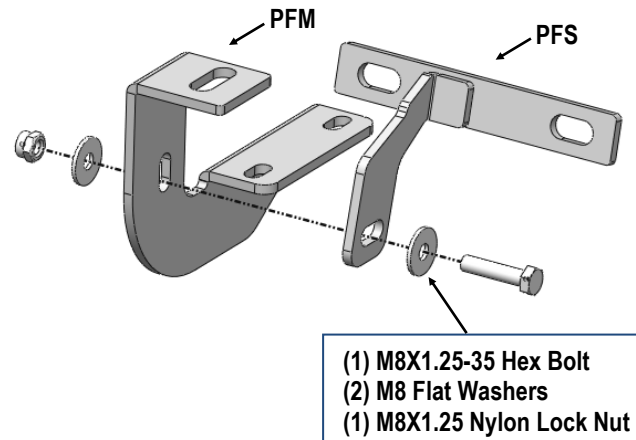

(Fig 6) Passenger Front Mounting Bracket Assembly

STEP 4

Attach the Passenger Front Support Bracket on the **back** of the pinch weld. Secure to the (2) pairs of holes on the pinch weld with (2) M6X1-25 Hex Bolts, (4) M6 Large Flat Washers & (2) M6X1 Nylon Lock Nuts (Figs 7 & 8). Do not fully tighten hardware at this time.

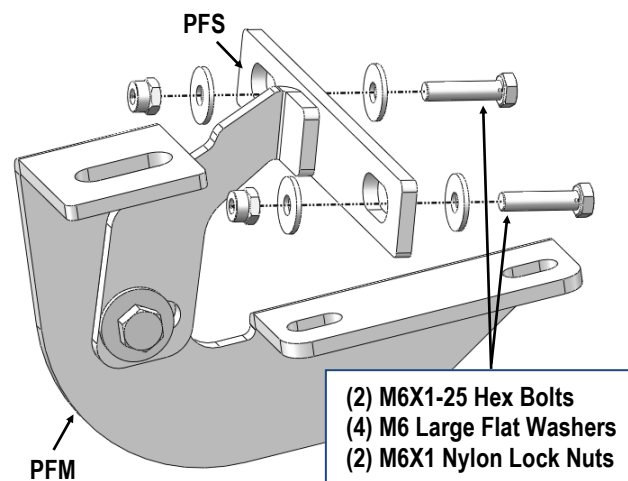

(Fig 7) Passenger Front Support Bracket Installation

iArmor[®]

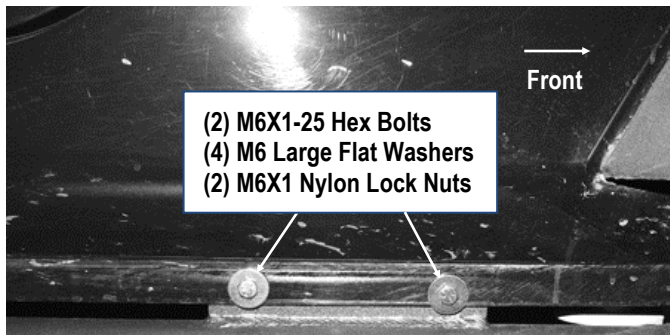

(Fig 8) Passenger Front Support Bracket Installed

STEP 5

Vehicles with open mounting location:

Bolt the Passenger Front Mounting Brackets to the M8X1.25 Nut Plate with (1) M8X1.25-35 Hex Bolt, (1) M8 Lock Washer and (1) M8 Large Flat Washer. (Fig 9). Do not fully tighten hardware at this time.

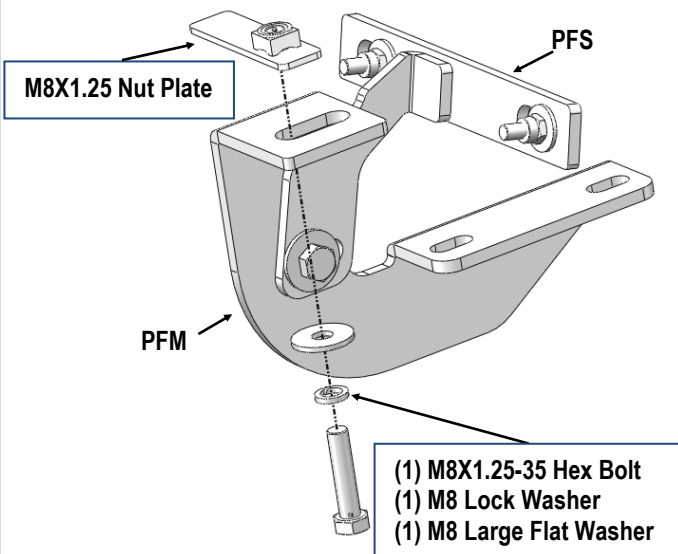

(Fig 9) Passenger Front Mounting Bracket Installed (Vehicles with open mounting location)

STEP 6

Vehicles with factory threaded hole in floor panel:

Bolt the Mounting Bracket to the threaded holes in the floor panel with (1) M8X1.25-35 Hex Bolt, (1) M8 Large Flat Washer, (1) M8 Lock Washer (Figs 10 & 11). Do not fully tighten hardware.

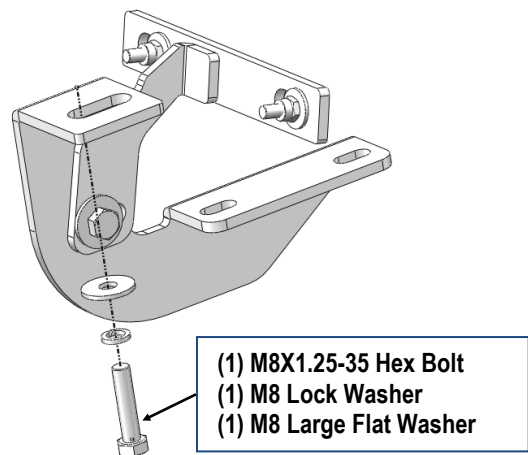

(Fig 10) Passenger Front Mounting Bracket Installed (Vehicles with factory threaded hole in floor panel)

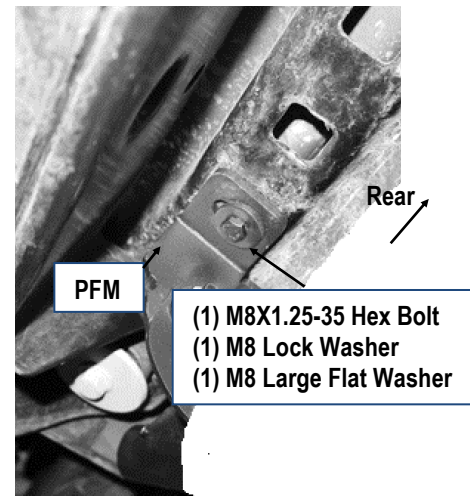

(Fig 11) Passenger Front Mounting Bracket Installed (Vehicles with factory threaded hole in floor panel)

iArmor®

STEP 7

Assemble Passenger Rear Mounting Bracket (PRM) and Passenger Rear Support Brackets (PRS1 & PRS2) (Fig 12). Do not fully tighten hardware at this time.

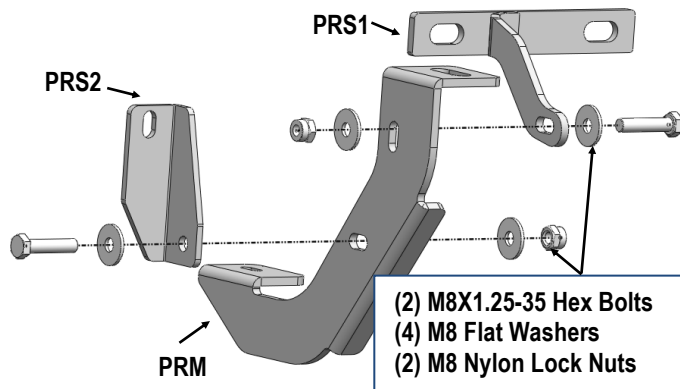

(Fig 12) Passenger Rear Mounting Bracket Assembly

STEP 8

Install the Assembled Passenger Rear Mounting Bracket onto the vehicle, (Figs 13-16).

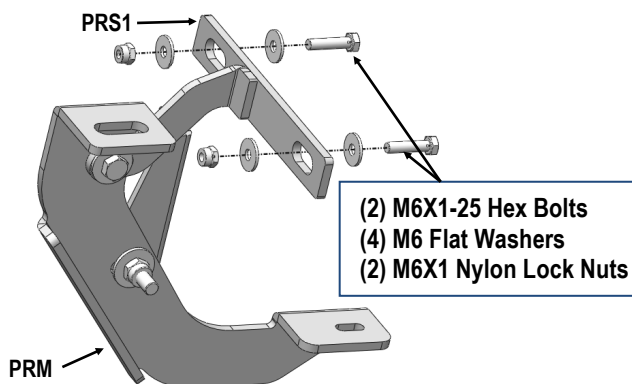

(Fig 13) Passenger Rear Support Bracket 1 Mounted to Pinch Weld

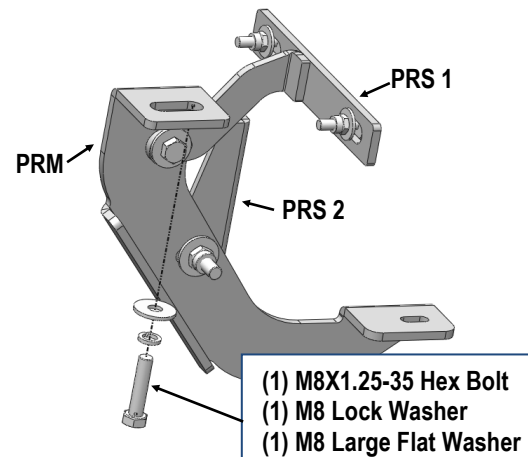

(Fig 14) Passenger Rear Mounting Bracket Installation (Vehicles with factory threaded hole in floor panel)

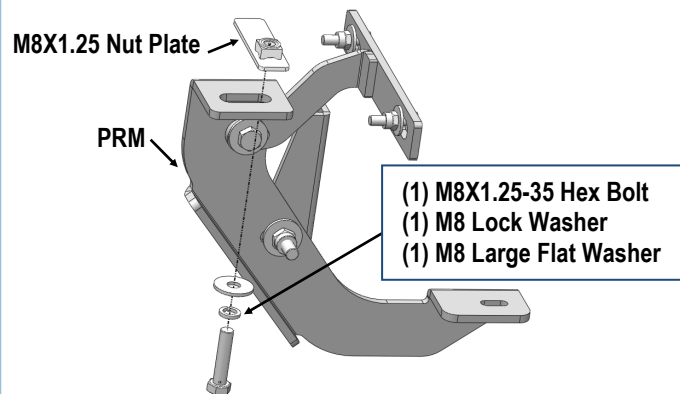

(Fig 15) Passenger Rear Mounting Bracket Installation (Vehicles with open mounting location)

STEP 9

Once all (2) brackets have been installed, select (3) M8X1.25-20mm T-Bolts, thread (1) M8 Plastic Washer on each T-Bolt, (Fig 16). Install the (3) M8X1.25-20mm T-Bolts with plastic washers in the slots on the assembled step bar. Rotate the T-Bolts to 90 degree, thread down the M8 Plastic Washers against the step bar (Fig 17).

NOTE: The Plastic Washer is designed to keep the T-Bolt in place to avoid falling into the tube during installation.

iArmor®

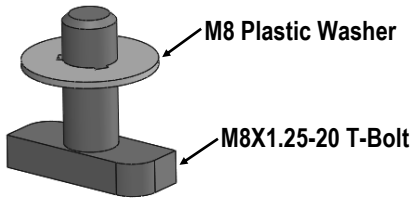

(Fig 16) Thread (1) M8 Plastic Washer on each T-Bolt Before Inserting into the slot !!!

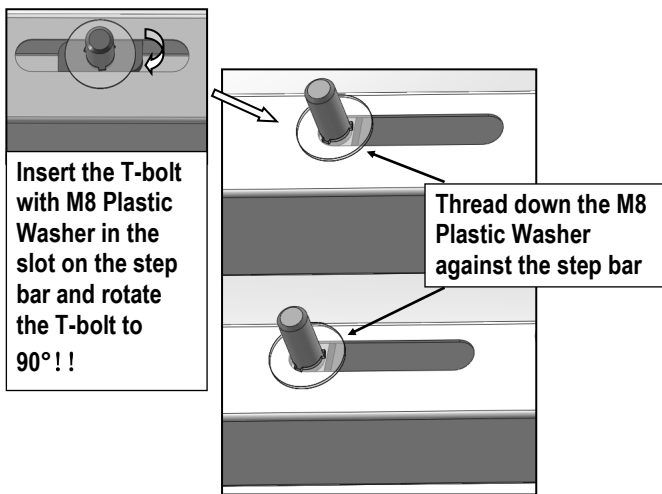

(Fig 17) T-Bolt with plastic washer in the slot

STEP 10

Attach the Assembled Passenger Side Step Bar onto the Mounting Brackets with (3) M8 Plastic Washers, (3) M8X1.25-20mm T-Bolts, (3) M8 Flat Washers, (3) M8 Nylon Lock Nuts, (Fig 18). Do not fully tighten hardware at this time.

NOTE: the Passenger Rear Mounting Bracket is located under the pedal. Slide (1) M6X1-20mm Square Head Bolt into the channel at the bottom of pedal (Fig 19). And secure the Rear Mounting Bracket to the pedal with (1) M6 Large Flat Washer and (1) M6 Nylon Lock Nut, (Fig 18). Do not fully tighten hardware at this time.

STEP 11

Level and adjust the assembled Step Bar properly and tighten all hardware.

Move to the other side of the vehicle. Repeat **Steps 2-10** for the other Side Step Bar installation.

Attention

Do periodic inspections to the installation to make sure that all hardware is secure and tight.

In order to protect your bars/boards, please use mild soap/non-abrasive products for cleaning only.

iArmor®

