

iArmor[®]

iArmor[®] by APS

PART#: IA-S310H

BEFORE INSTALLATION

REMOVE CONTENTS FROM BOX. VERIFY ALL PARTS ARE PRESENT. READ INSTRUCTIONS CAREFULLY BEFORE STARTING INSTALLATION. ASSISTANCE IS RECOMMENDED. THANK YOU FOR CHOOSING OUR PRODUCT!

***ROCKER PANEL MOUNT**

***NO DRILLING / TRIMMING REQUIRED**

Torque Value

| Fastener Size | Tightening Torque (ft-lbs) | Required |
|---------------|----------------------------|----------|
| 6mm | 6-7 | X |
| 8mm | 16-18 | √ |
| 10mm | 31-32 | √ |
| 12mm | 56-58 | X |
| 14mm | 92-94 | X |

PART LIST

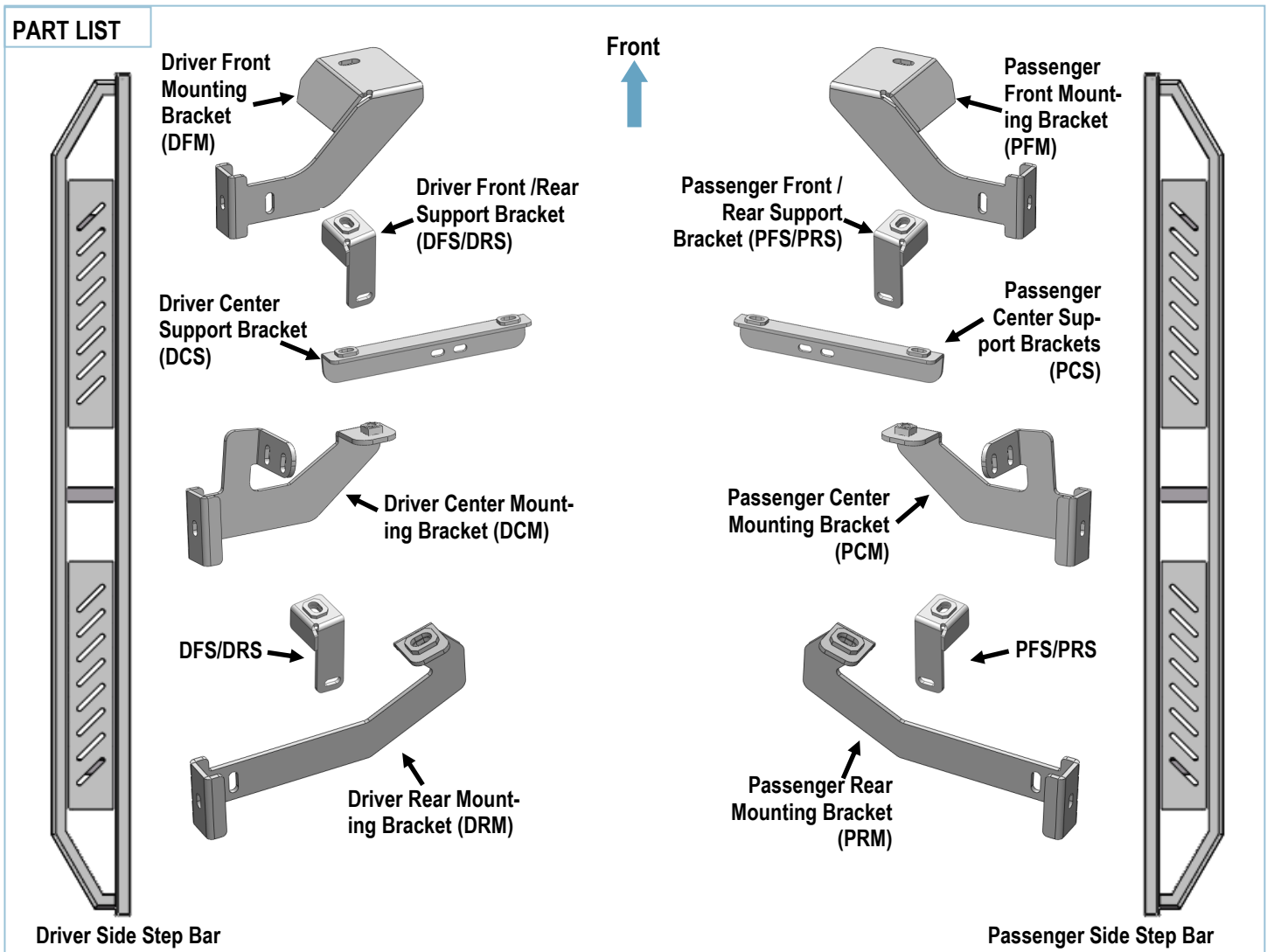

Customer Support: info@iarmorauto.com

iArmor®

| Hardware Package A (For Bracket Installation) | | | | | |
|-----------------------------------------------|-----|------------------------|------|-----|------------------------|
| Item | QTY | Description | Item | QTY | Description |
| 1# | 6 | U Brackets | 8# | 14 | M10 Large Flat Washers |
| 2# | 2 | Support Plates | 9# | 14 | M10 Lock Washers |
| 3# | 2 | M10X35 Bolt Plates | 10# | 14 | M10 Hex Nuts |
| 4# | 2 | M10X40 Bolt Plates | 11# | 8 | M8X1.25-25 Hex Bolts |
| 5# | 8 | M10 J-Bolts | 12# | 16 | M8 Large Flat Washers |
| 6# | 4 | M10 Plastic Washers | 13# | 8 | M8 Lock Washers |
| 7# | 2 | M10X1.5-60mm Hex Bolts | 14# | 8 | M8 Hex Nuts |

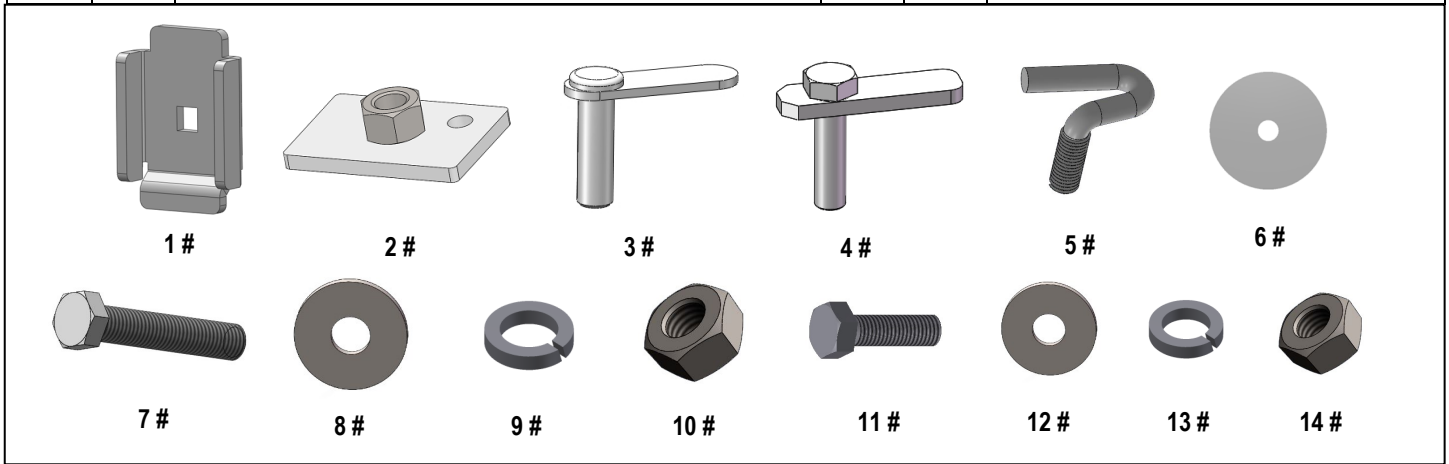

| Hardware Package B (For Step Bar Installation) | | | | | |
|------------------------------------------------|-----|-----------------------------|------|-----|-----------------|
| Item | QTY | Description | Item | QTY | Description |
| 1# | 6 | M8X1.25-55mm Carriage Bolts | 3# | 6 | M8 Lock Washers |
| 2# | 6 | M8 Large Flat Washers | 4# | 6 | M8 Hex Nuts |

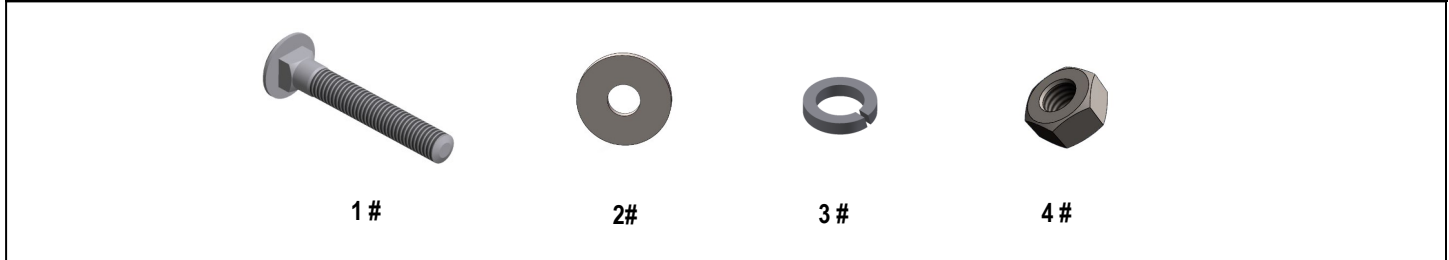

Customer Support: info@iarmorauto.com

iArmor®

The instruction here is for your reference only. We strongly recommend the professional installer for best result. We are not responsible for any damage caused by the installation.

STEP 1

Start the installation from Driver Side Mounting Locations. Remove the large plastic cover on the bottom of the floor panel if equipped, (Fig 1). Determine which plastic clips need to be removed. Carefully remove only the plastic clips for installation.

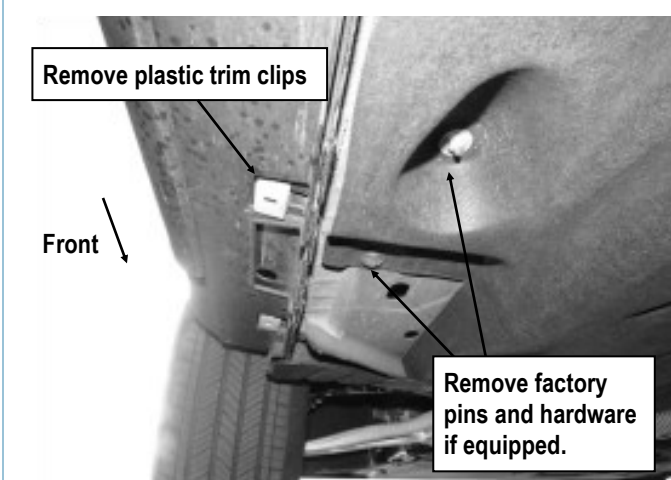

(Fig 1) Driver Side Front Mounting Location

STEP 2

Locate the Driver Side Front Mounting Location, (Fig 2).

Insert (1) M10X35 Bolt Plate into the slot on the floor panel, (Fig 2). Thread (1) M10 Plastic Washer onto the Bolt Plate to hold it in place within the bracket installation.

Select (1) M10 J-Bolt, insert the tail of J-Bolt all the way up into the round hole on the side panel. Rotate and pull the J-Bolt outwards, keep the thread pointing to the ground, (Fig 3).



NOTE: Scan the QR code or follow link for M10 J-Bolt installation video.

<https://youtu.be/BqQis3QjZnc>

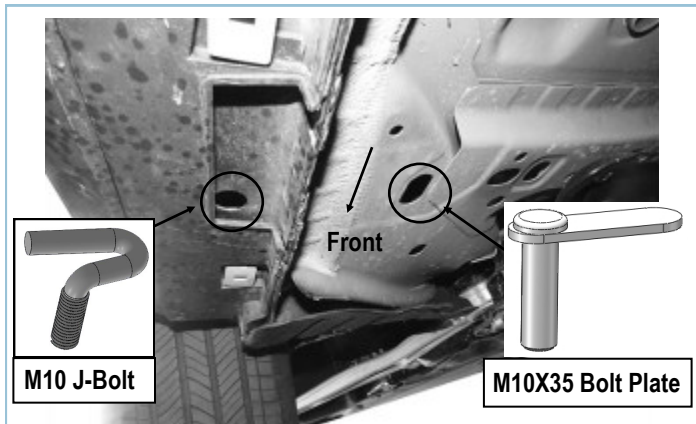

(Fig 2) Driver Side Front Mounting Location



(Fig 3) M10 J-Bolt Installation
(On Driver Side Mounting Location)

iArmor®

STEP 3

Select the Driver Front Mounting Bracket (**DFM**) and the Driver Front Support Bracket (**DFS/DRS**), assemble with (1) M8X1.25-25mm Hex Bolt, (2) M8 Large Flat Washers, (1) M8 Lock Washer and (1) M8X1.25 Hex Nut, (**Fig 4**). Do not fully tighten at this time.

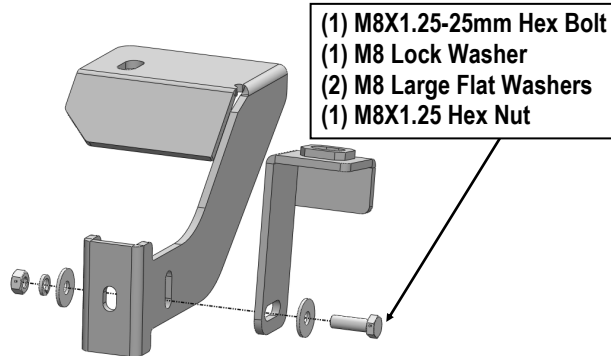

(Fig 4) Driver Front Brackets Assembly

STEP 4

Attach the assembled Mounting Bracket to the installed M10X35 Bolt Plate with (1) M10 Large Flat Washer, (1) M10 Lock Washer and (1) M10X1.5 Hex Nut.

Secure the Drive Front Support Bracket (**DFS/DRS**) to the installed M10 J-Bolt with (1) M10 Large Flat Washer, (1) M10 Lock Washer and (1) M10X1.5 Hex Nut, (**Fig 5**). Do not fully tighten at this time.

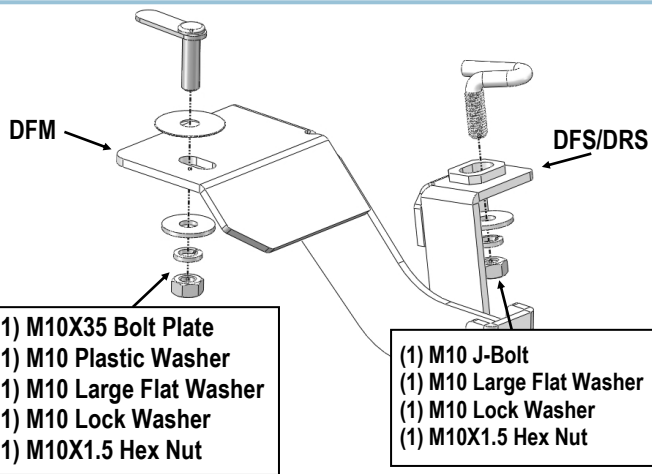

(Fig 5) Driver Front Mounting Bracket Installation

STEP 5

Select the Driver Center Mounting Bracket (**DCM**) and the Driver Center Support Bracket (**DCS**), assemble with (2) M8X1.25-25mm Hex Bolts, (4) M8 Large Flat Washers, (2) M8 Lock Washers and (2) M8X1.25 Hex Nuts, (**Fig 6**). Do not fully tighten at this time.

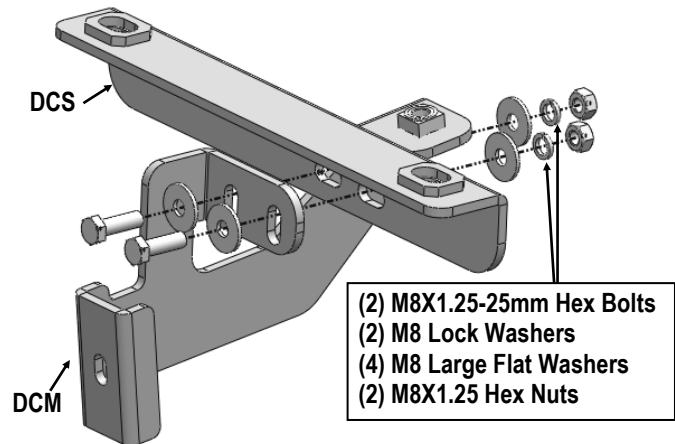

(Fig 6) Driver Side Center Brackets Assembly

STEP 6

Move to the Driver Side Center Mounting Location, (**Fig 7**). Insert (2) M10 J-Bolts into the side panel, (**Fig 8**). Attach the Driver Center Support Bracket (**DCS**) to the installed (2) M10 J-Bolts with (2) M10 Large Flat Washers, (2) M10 Lock Washers and (2) M10X1.5 Hex Nuts, (**Fig 9**). Do not fully tighten at this time.

Select and install (1) Support Plate (**Fig 9**):

- Thread (1) M10X1.5 Hex Nut to (1) M10X1.5-60mm Hex Bolt. Slide (1) M10 Lock Washer and (1) M10 Flat washer onto the M10X1.5-60mm Hex Bolt. (**NOTE:** Use the M10X1.5 Hex Nut to adjust the level of the Mounting Bracket.)
- Thread the M10X1.5-60mm Hex Bolt assembly into the welded nut on the back of the Mounting Bracket. Place the Support Plate onto the end of the M10 Hex Bolt, (**Fig 9**).
- Tighten Hex Bolt to attach the Support Plate onto the floor panel. Do not tighten Hex Bolt all the way.

NOTE: Scan the QR code or follow link for Support Plate installation.

<https://www.youtube.com/watch?v=R51s7Vk1Sy4>



iArmor®

STEP 7

Move to the Driver Side Rear Mounting Location, **(Fig 10)**. Repeat **Steps 2-4** to attach the Driver Rear Mounting Brackets, **(Figs 10—13)**. Do not fully tighten hardware.

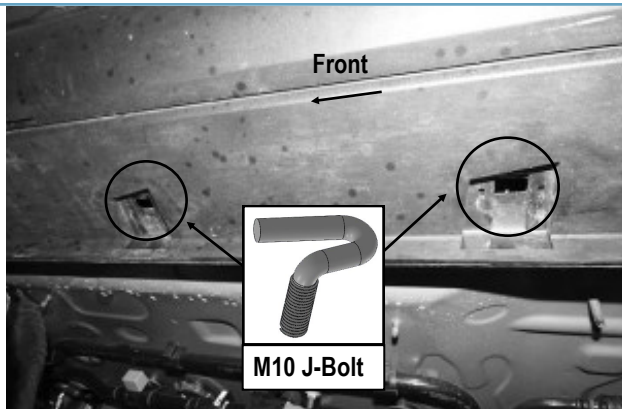

(Fig 7) Driver Side Center Mounting Location

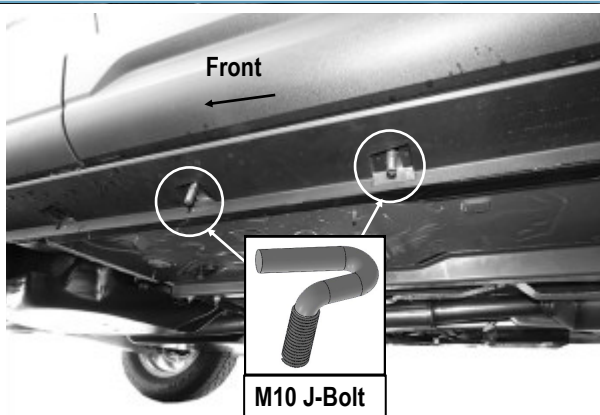

**(Fig 8) M10 J-Bolts Installation
(On Driver Side Center Mounting Location)**

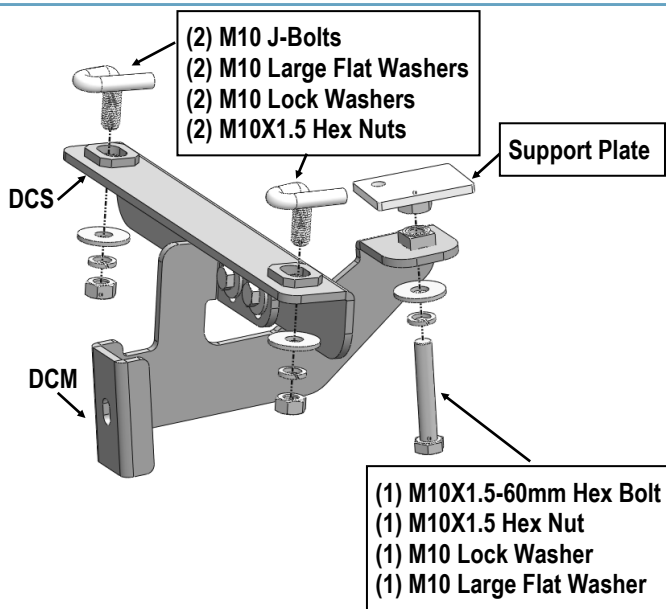

(Fig 9) Driver Center Brackets Installation



(Fig 10) Driver Side Rear Mounting Location

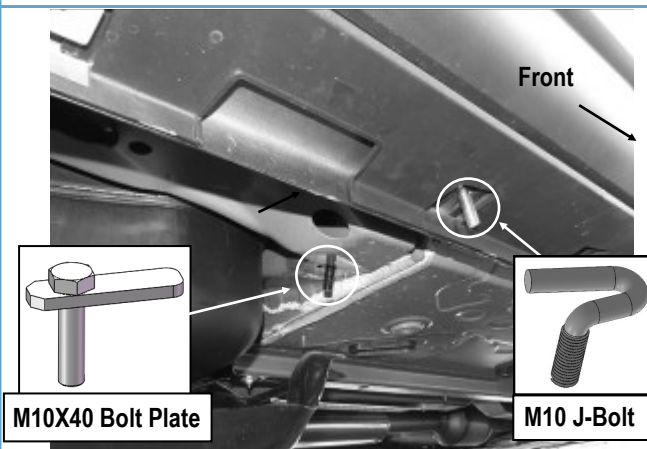

(Fig 11) Insert (1) M10 J-Bolt And (1) M10X40 Bolt Plate

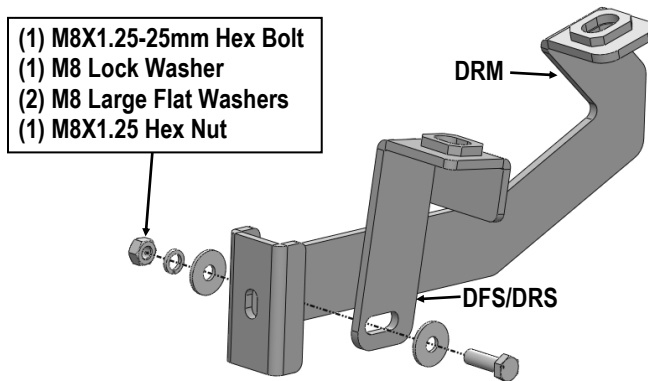

(Fig 12) Driver Rear Brackets Assembly

iArmor®

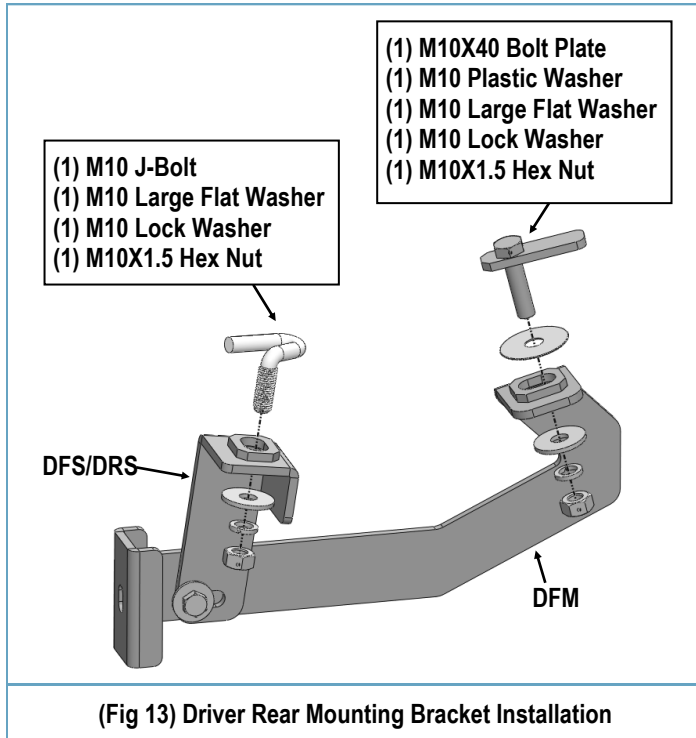

STEP 9

Properly level and adjust the Step Bar and fully tighten all hardware.

STEP 10

Move to the other side of the vehicle. Repeat **Steps 1-9** to install passenger side step bar.

Installation completed.

Attention

Do periodic inspections to the installation to make sure that all hardware is secure and tight.

In order to protect your bars/boards, please use mild soap/non-abrasive products for cleaning only.

STEP 8

Once all (3) driver side mounting brackets are installed, select and attach the Driver Side Step Bar onto the Mounting Brackets with (3) U Brackets, (3) M8X1.25-55mm Carriage Bolts, (3) M8 Large Flat Washers, (3) M8 Lock Washers and (3) M8X1.25 Hex Nuts, (**Fig 14**). Do not fully tighten hardware at this time.

iArmor[®]

NOTE: Torque all M8 X1.25-55mm Carriage Bolts to 16~18 lb-ft. Don't over tighten, or the square bars will be damaged by the brackets

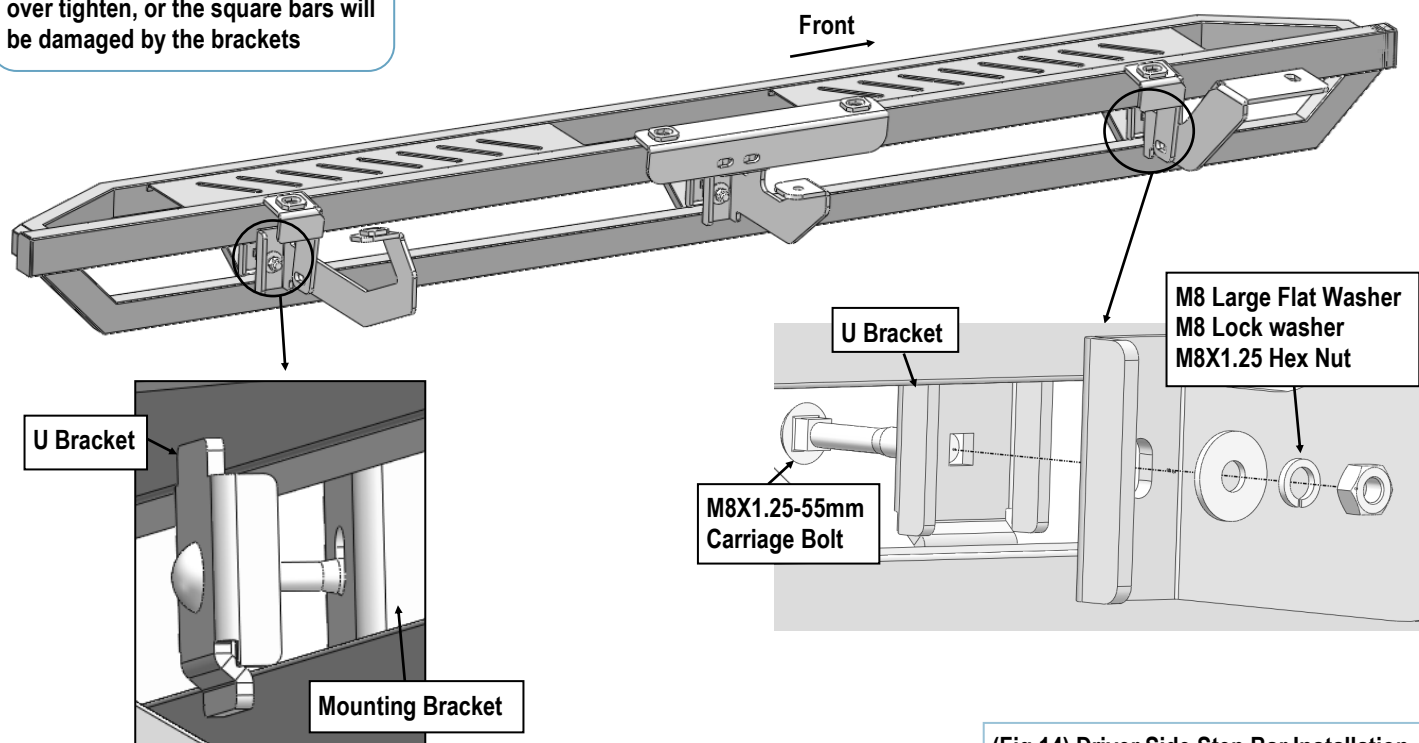

(Fig 14) Driver Side Step Bar Installation