

# iArmor®

## IARMOR EDGE™

PART#: IA-N011H

### BEFORE INSTALLATION

REMOVE CONTENTS FROM BOX. VERIFY ALL PARTS ARE PRESENT. READ INSTRUCTIONS CAREFULLY BEFORE STARTING INSTALLATION. ASSISTANCE IS RECOMMENDED. THANK YOU FOR CHOOSING OUR PRODUCT!

\*ROCKER PANEL MOUNT

\*DRILLING NOT REQUIRED

### Torque Value

Fastener Size	Tightening Torque (ft-lbs)	Required
6mm	6-7	√
8mm	16-18	√
10mm	31-32	√
12mm	56-58	X
14mm	92-94	X

### PART LIST

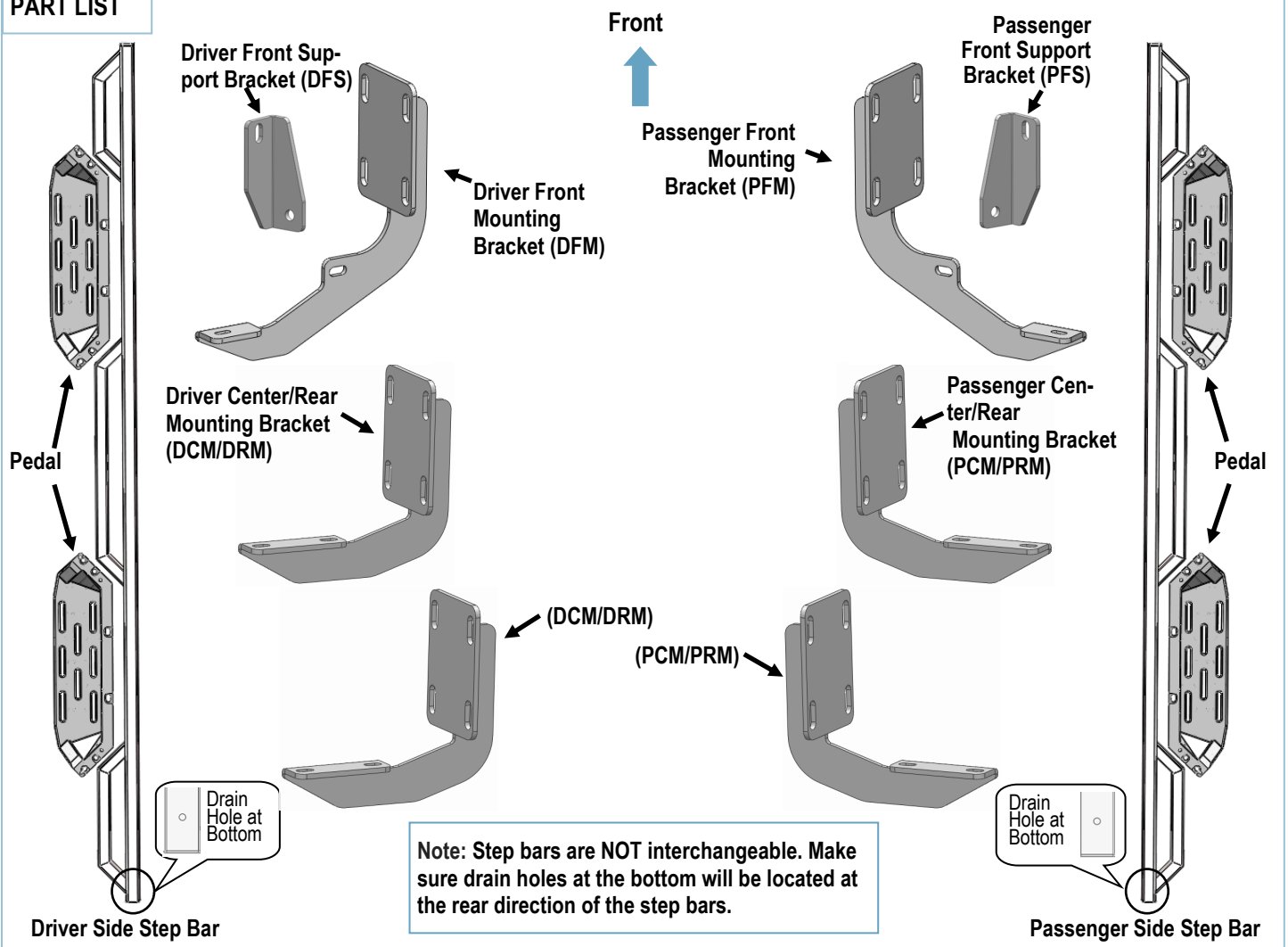









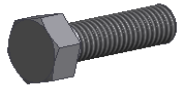

Customer Support: [info@iarmorauto.com](mailto:info@iarmorauto.com)

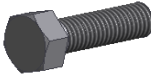
# iArmor®

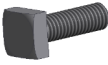

Hardware Package A (For Brackets & Bars Installation)					
Item	QTY	Description	Item	QTY	Description
1#	24	M10X1.5-30mm Hex Bolts	8#	12	M8 Nylon Lock Nuts
2#	36	M10 Large Flat Washers	9#	2	M6X1-20 Square Head Bolts
3#	24	M10 Lock Washers	10#	2	M6 Large Flat Washers
4#	12	M10 Hex Nuts	11#	2	M6 Nylon Lock Nuts
5#	12	M10 Clip Nuts	12#	10	M8X1.25-20 T-Bolts
6#	2	M8X1.25-30 Hex Bolts	13#	10	M8 Plastic Washers
7#	14	M8 Large Flat Washers			

						
1 #	2 #	3 #	4 #	5 #	6 #	7 #
						
8 #	9 #	10 #	11 #	12 #	13 #	

Hardware Package B (For Step Pedals Installation)					
Item	QTY	Description	Item	QTY	Description
1#	24	M8X1.25-25 Hex Bolts	3#	24	M8 Lock Washers
2#	24	M8 Large Flat Washers			

		
1#	2#	3#

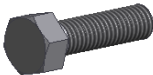
Customer Support: [info@iarmorauto.com](mailto:info@iarmorauto.com)

# iArmor®

The instruction here is for your reference only. We strongly recommend the professional installer for best result. We are not responsible for any damage caused by the installation.

## STEP 1

Install (4) Pedals onto the step bars with (24) M8X1.25-25mm Hex Bolts, (24) M8 Large Flat Washers and (24) M8 Lock Washers.

**IMPORTANT:** Don't punch the pedal with any metal hammer within pedal installation, or the pedal will be damaged.

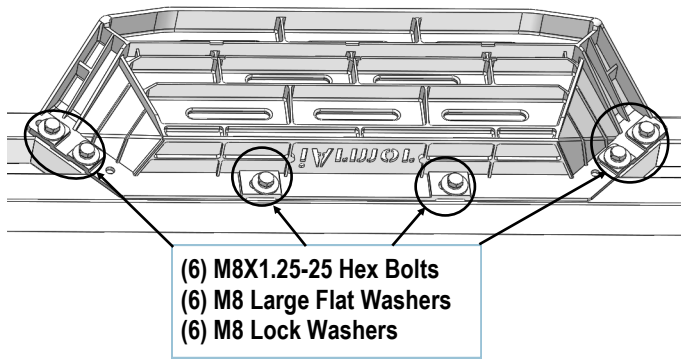

## STEP 2

Starting installation from the passenger side of the vehicle, locate the (5) pairs of factory holes along the pinch weld. Move to the 2nd pair of holes directly under the center of the front door, (Figs 1 & 2). **NOTE:** There are (5) mounting locations along the inner body panel. Running Board installation will use the 2nd, 3rd and 5th mounting locations, (Fig 1).

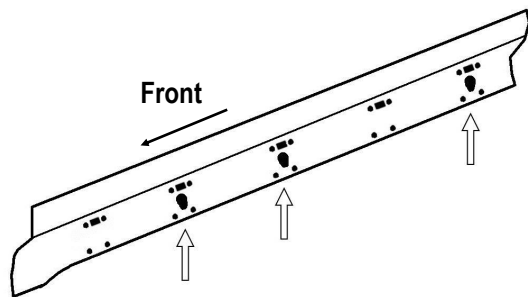

(Fig 1) Passenger Side Rocker Panel Mounting Locations (See Arrows)

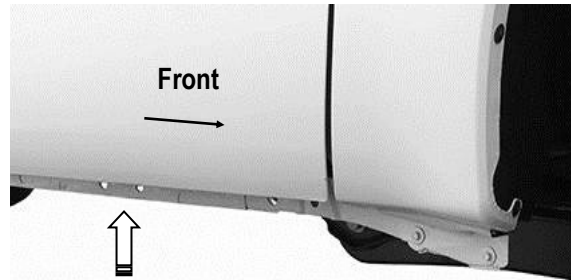

(Fig 2) Passenger Side Front Mounting Location  
(The 2nd Pair of Factory Holes on Pinch Weld)

## STEP 3

Select (2) M10 Clip Nuts. Insert Clip Nuts into the round hole beside the rectangular opening. **NOTE:** Threaded nuts must go towards the inside of the side panel, (Figs 3 & 4).

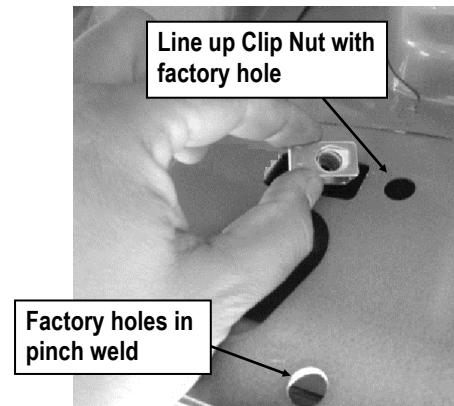

(Fig 3) Typical Mounting Location

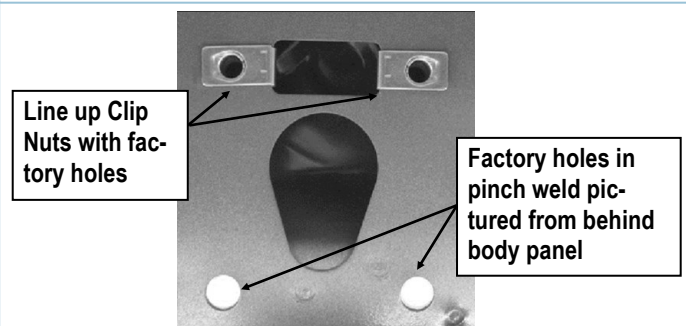

(Fig 4) M10 Clip Nut Installation

# iArmor®

## STEP 4

Assemble the Passenger Front Mounting Bracket (PFM) and Passenger Front Support Bracket (PFS) with (1) M8X1.25-30 Hex Bolt, (2) M8 Large Flat Washers and (1) M8 Nylon Lock Nut, (Fig 5). Do not fully tighten hardware at this time.

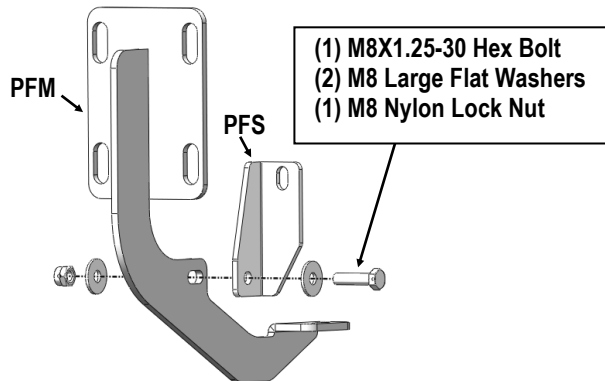

(Fig 5) Passenger Front Mounting Bracket Assembly

## STEP 5

Attach the Assembled Passenger Front Bracket to the Clip Nuts with (2) M10X1.5-30 Hex Bolts, (2) M10 Lock Washers and (2) M10 Large Flat Washers, (Fig 6). Attach lower holes to (2) holes on the pinch weld with (2) M10X1.5-30 Hex Bolts, (4) M10 Large Flat Washers, (2) M10 Lock Washers and (2) M10 Hex Nuts, (Fig 6). Do not fully tighten hardware at this time.

**NOTE:** Insert the Hex Bolt with Flat Washer through pinch weld first then through the Bracket from outside to inside.

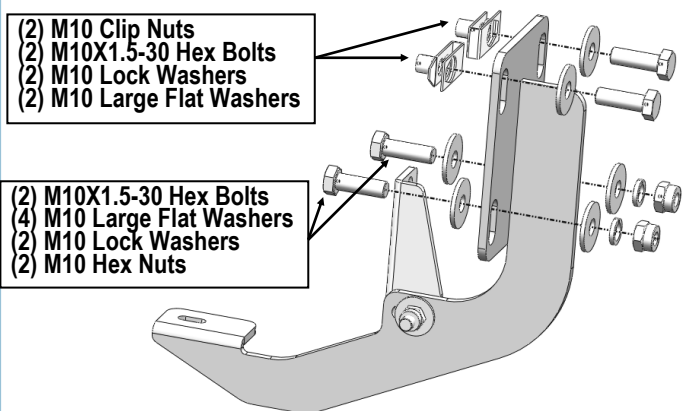

(Fig 6) Passenger Front Bracket Installation

## STEP 6

Move to the Passenger Side Center and Rear Mounting locations, (Fig 7). Repeat Steps 3 & 5 to install the Passenger Center/Rear Mounting Brackets (PCM/PRM), (Fig 8).

**Note:** Passenger Center and Rear Mounting Brackets are universal.

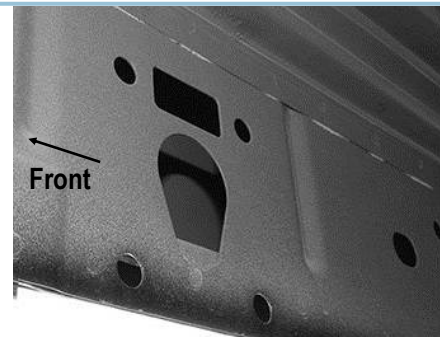

(Fig 7) Passenger Side Center Mounting Location

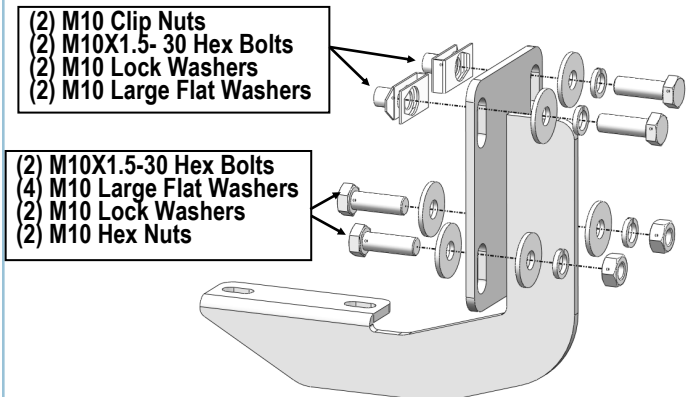

(Fig 8) Passenger Center/Rear Mounting Bracket Installation

## STEP 7

Once all (3) brackets have been installed, select (5) M8X1.25-20mm T-Bolts, thread (1) M8 Plastic Washer on each T-Bolt, (Fig 9). Install the (5) M8X1.25-20mm T-Bolts with plastic washers in the slots on the assembled Passenger side step bar. Rotate the T-Bolts to 90 degree, thread down the M8 Plastic Washers against the step bar (Fig 10).

**NOTE:** The Plastic Washer is designed to keep the T-Bolt in place to avoid falling into the tube during installation.

# iArmor<sup>®</sup>

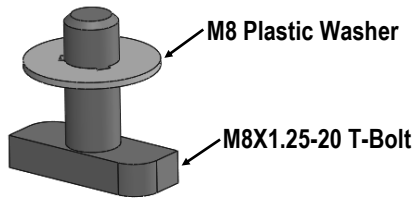

(Fig 9) Thread (1) M8 Plastic Washer on each T-Bolt Before Inserting into the slot !!!

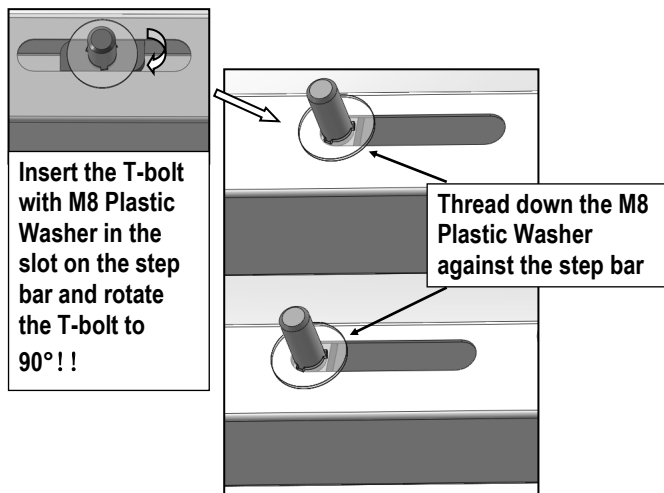

(Fig 10) T-Bolt with plastic washer in the slot

## STEP 8

Attach the Assembled Passenger Side Step Bar onto the Mounting Brackets with (5) M8 Plastic Washers, (5) M8X1.25-20mm T-Bolts, (5) M8 Large Flat Washers, (5) M8 Nylon Lock Nuts, (Fig 11). Do not fully tighten hardware at this time.

**NOTE:** the Passenger Front Mounting Bracket is located under the front pedal. Slide (1) M6X1-20mm Square Head Bolt into the channel at the bottom of front pedal (Fig 12). And secure the Passenger Front Mounting Bracket to the pedal with (1) M6 Large Flat Washer and (1) M6 Nylon Lock Nut, (Fig 11). Do not fully tighten hardware at this time.

## STEP 9

Level and adjust the assembled Step Bar properly and tighten all hardware.

Move to the other side of the vehicle. Repeat **Steps 2-8** for the other Side Step Bar installation.

### Attention

Do periodic inspections to the installation to make sure that all hardware is secure and tight.

In order to protect your bars/boards, please use mild soap/non-abrasive products for cleaning only.

# iArmor<sup>®</sup>

