

iArmor®

IARMOR EDGE™

PART#: IA-N152H

BEFORE INSTALLATION

REMOVE CONTENTS FROM BOX. VERIFY ALL PARTS ARE PRESENT. READ INSTRUCTIONS CAREFULLY BEFORE STARTING INSTALLATION. ASSISTANCE IS RECOMMENDED. THANK YOU FOR CHOOSING OUR PRODUCT!

*ROCKER PANEL MOUNT

*DRILLING IS REQUIRED

Torque Value

Fastener Size	Tightening Torque (ft-lbs)	Required
6mm	6-7	X
8mm	16-18	√
10mm	31-32	√
12mm	56-58	X
14mm	92-94	X

PART LIST

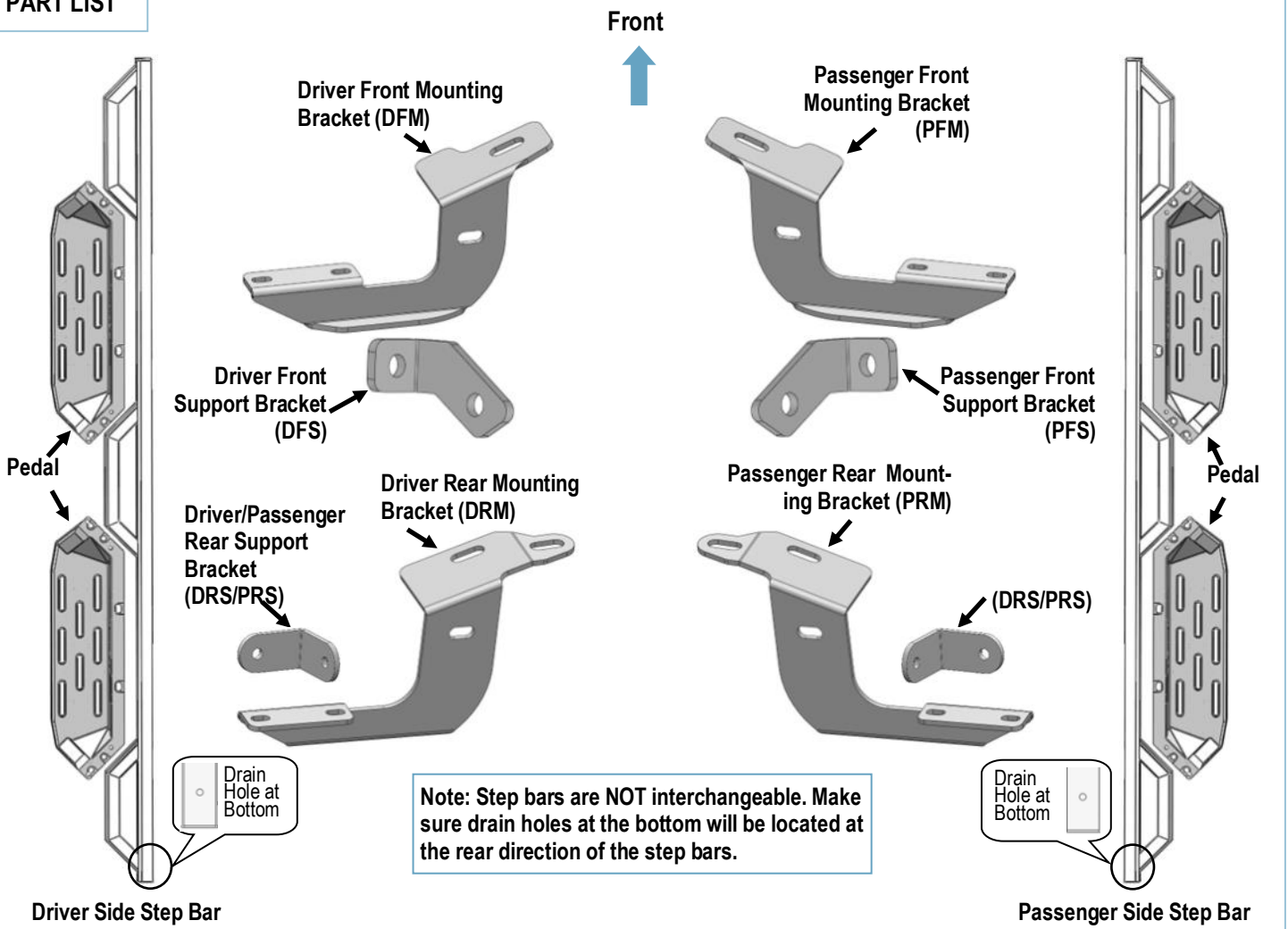

Customer Support: info@iarmorauto.com

iArmor[®]

Hardware Package A (For Brackets & Bars Installation)					
Item	QTY	Description	Item	QTY	Description
1#	1	Insert Installation Tool	9#	8	M8X1.25-25 Hex Bolts
2#	2	M10X35 T-Bolt Plates	10#	20	M8 Large Flat Washers
3#	2	M10X40 Bolt Plates	11#	8	M8 Lock Washers
4#	2	M10X35 Bolt Plates	12#	4	M8 Hex Nuts
5#	6	M10 Plastic Washers	13#	4	M8 Rivet Nuts
6#	6	M10 Large Flat Washers	14#	8	M8X1.25-20 T-Bolts
7#	6	M10 Lock Washers	15#	8	M8 Plastic Washers
8#	6	M10 Hex Nuts	16#	8	M8 Nylon Lock Nuts

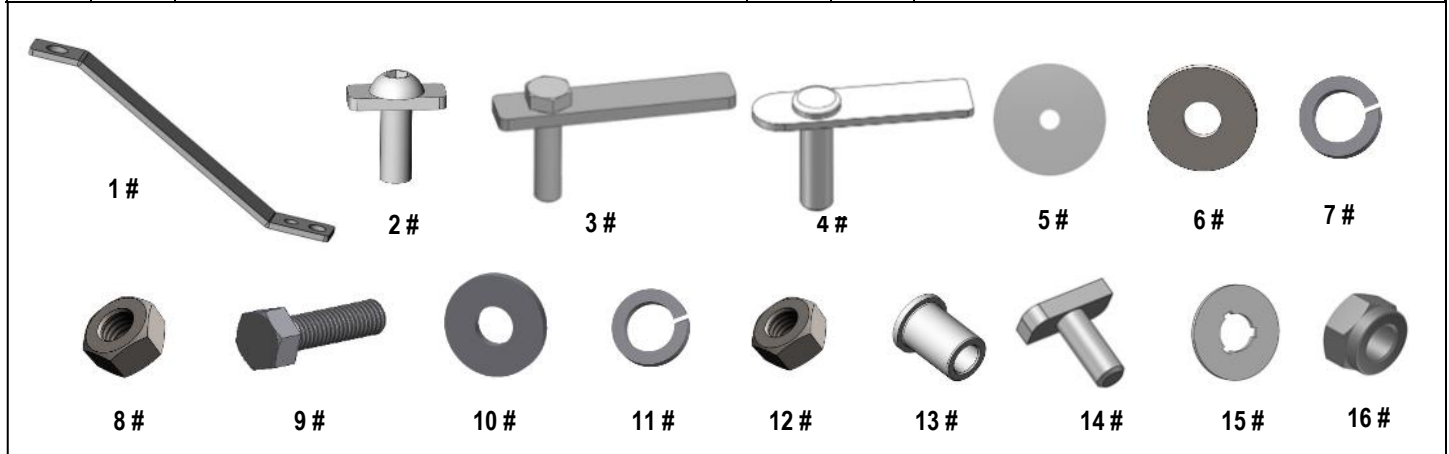

Hardware Package B (For Step Pedals Installation)					
Item	QTY	Description	Item	QTY	Description
1#	24	M8X1.25-25 Hex Bolts	3#	24	M8 Lock Washers
2#	24	M8 Large Flat Washers			

Customer Support: info@iarmorauto.com

iArmor®

The instruction here is for your reference only. We strongly recommend the professional installer for best result. We are not responsible for any damage caused by the installation.

STEP 1

Install (4) Pedals onto the step bars with (24) M8X1.25-25mm Hex Bolts, (24) M8 Large Flat Washers and (24) M8 Lock Washers.

IMPORTANT: Don't punch the pedal with any metal hammer within pedal installation, or the pedal will be damaged.

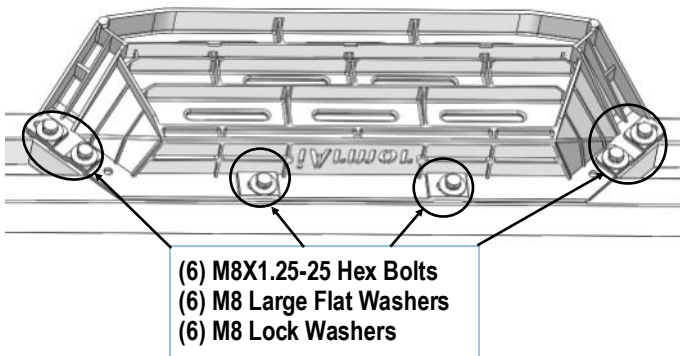

STEP 2

Start installation under the driver side front of the vehicle. Select and insert (1) M10X35 T-Bolt Plate into the factory oval hole in the floor panel, (**Figs 1A & 1B**). Rotate the Bolt Plate 90-degrees so that the plate is across in the oval hole. Thread (1)M10 Plastic Washer on the M10X35 T-Bolt. Install the Driver Front Mounting Bracket (**DFM**) to the installed M10X35 T-Bolt Plate with (1) M10 Large Flat Washer, (1) M10 Lock Washer and (1) M10 Hex Nut, (**Fig 2**).

NOTE: The Plastic Washer is designed to keep the T-Bolt in place to avoid from falling into the body panel during bracket installation.

M10 X 35 T-Bolt Plate

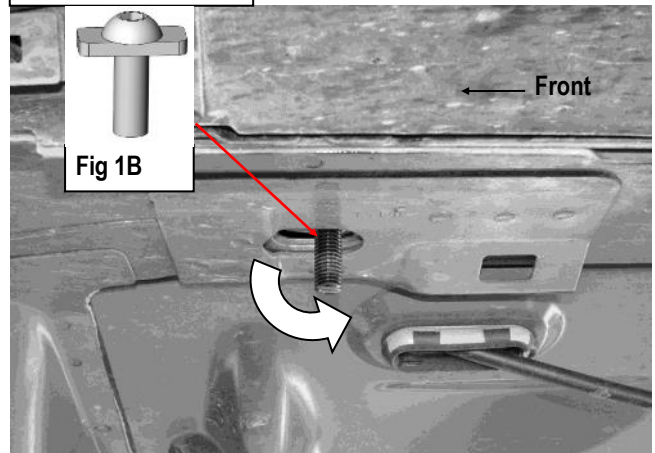

(Fig 1A) M10X35 T-Bolt Plate Installation

- (1) M10X35 T-Bolt
- (1) M10 Plastic Washer
- (1) M10 Large Flat Washer
- (1) M10 Lock Washer
- (1) M10 Hex Nut

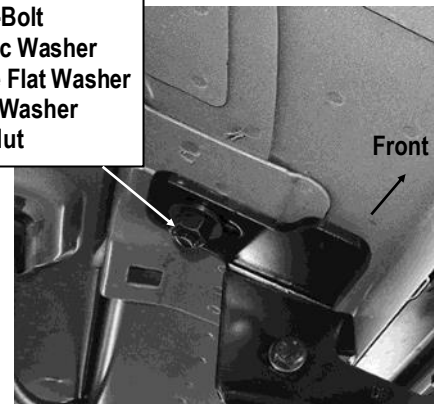

(Fig 2) Driver Front Mounting Bracket Installed

STEP 3

Select the Driver Front Support Bracket (**DFS**), (**Fig 3A**). Bolt the Driver Front Support Bracket to the back of the Driver Front Mounting Bracket with (1) M8X1.25-25mm Hex Bolt, (2) M8 Large Flat Washers, (1) M8 Lock Washer and (1) M8 Hex Nut, (**Figs 3 & 4**).

Note: Line up the mounting tab on the Support Bracket to the inner side of the pinch weld. Do not fully tighten hardware at this time.

iArmor®

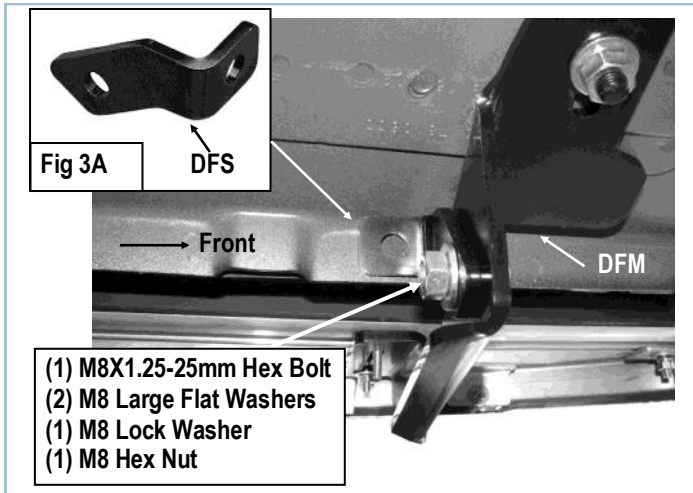

(Fig 3) Attach Driver Front Support Bracket to Driver Front Mounting Bracket

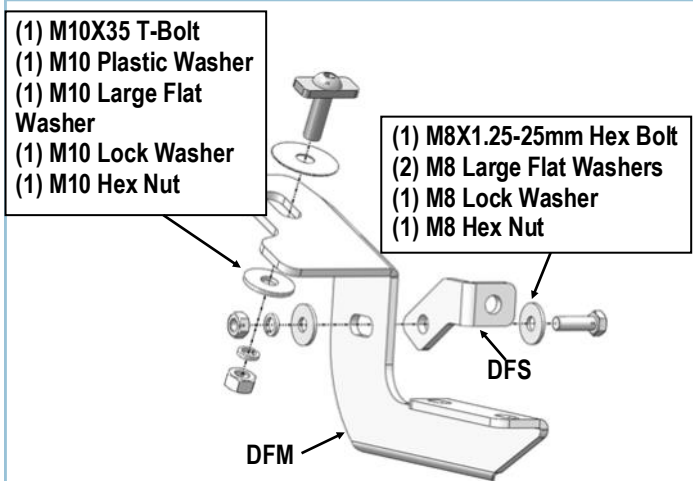

(Fig 4) Driver Front Mounting Brackets Installation

STEP 4

Move to the Driver Side Rear Mounting Location. Locate the oval and round holes on the floor panel, (Fig 5). Insert (1) M10X35 Bolt Plate into the round hole, (Fig 5B). Insert (1) M10X40 Bolt Plate into the oval hole next to the pinch weld, (Fig 5C). Rotate 90-degree for the M10X40 Bolt Plate till the plate across on the oval hole. Thread (1) M10 Plastic Washer on each Bolt Plate.

NOTE: The Plastic Washer is designed to keep the Bolt Plate in place to avoid from falling into the body panel.

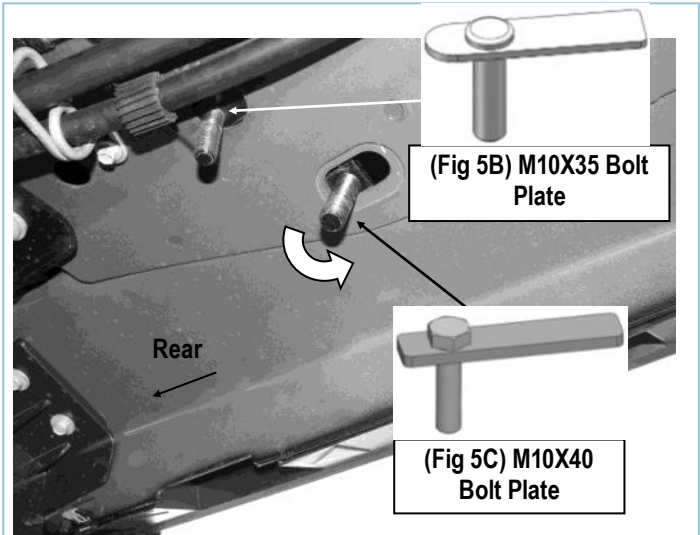

(Fig 5) Driver Rear Mounting Bracket Installation

STEP 5

Attach the Driver Rear Mounting Bracket (DRM) to the (2) installed M10 Bolt Plates with (2) M10 Large Flat Washers, (2) M10 Lock Washers and (2) M10 Hex Nuts, (Figs 6&7). Do not fully tighten hardware at this time.

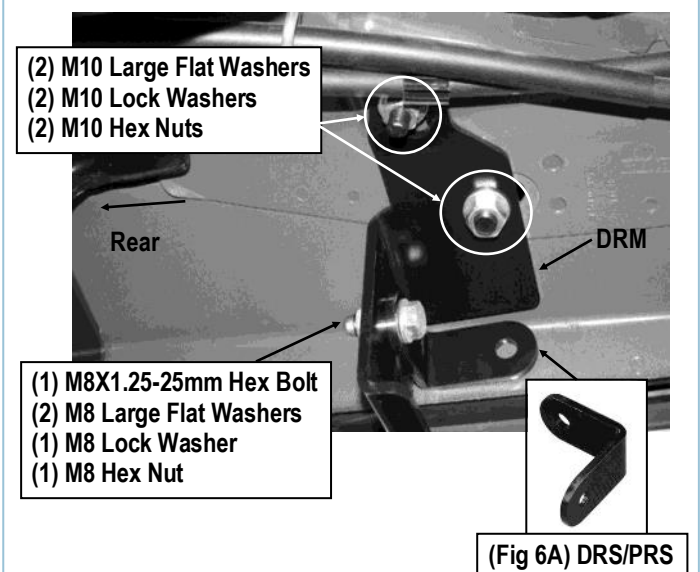

(Fig 6) Driver Rear Mounting Bracket Installed

iArmor®

STEP 6

Next, select (1) Driver Rear Support Bracket (**DRS/PRS**), (**Fig 6A**). Bolt the Support Bracket to the front side of the Driver Rear Mounting Bracket (**DRM**) with (1) M8X1.25-25mm Hex Bolt, (2) M8 Large Flat Washers, (1) M8 Lock Washer and (1) M8 Hex Nut, (**Figs 6 & 7**). Do not fully tighten hardware at this time.

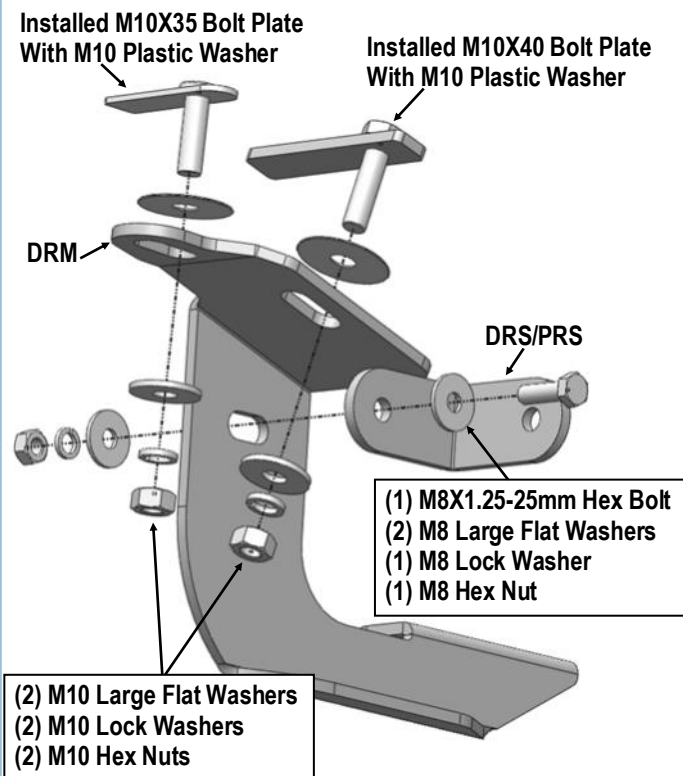

(Fig 7) Driver Side Rear Brackets Installation

STEP 7

Once all (2) brackets have been installed, select (4) M8X1.25-20mm T-Bolts, thread (1) M8 Plastic Washer on each T-Bolt, (**Fig 8**). Install the (4) M8X1.25-20mm T-Bolts with plastic washers in the slots on the assembled Driver side step bar. Rotate the T-Bolts to 90 degree, thread down the M8 Plastic Washers against the step bar (**Fig 9**).

NOTE: The Plastic Washer is designed to keep the T-Bolt in place to avoid falling into the tube during installation.

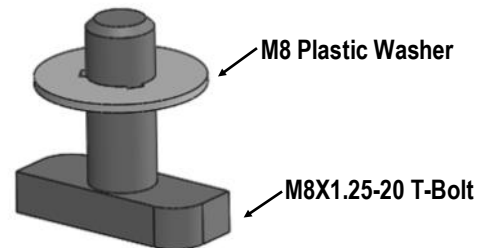

(Fig 8) Thread (1) M8 Plastic Washer on each T-Bolt Before Inserting into the slot !!!

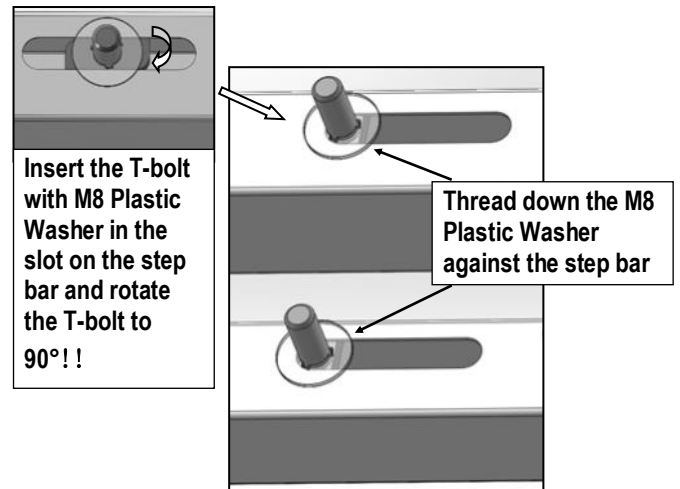

(Fig 9) T-Bolt with plastic washer in the slot

STEP 8

Attach the Assembled Driver Side Step Bar onto the Mounting Brackets with (4) M8 Plastic Washers, (4) M8X1.25-20mm T-Bolts, (4) M8 Large Flat Washers, (4) M8 Nylon Lock Nuts, (**Fig 10**). Do not fully tighten hardware at this time.

iArmor®

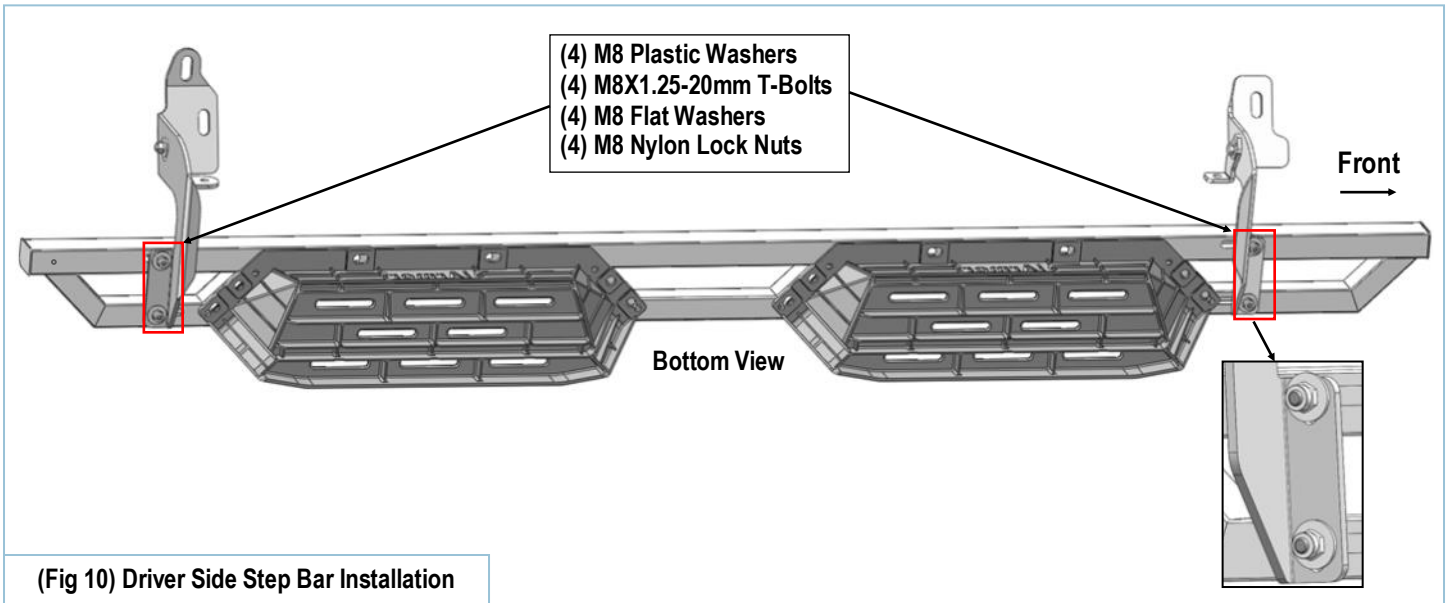

(Fig 10) Driver Side Step Bar Installation

STEP 9

Return to the Driver Front Mounting Bracket (DFM) and Driver Front Support Bracket (DFS). Hold the Front Support Bracket firmly against the inner of the pinch weld. Mark the mounting hole location onto the inner side of the pinch weld, (Fig 11).

Make sure the Running Board is level, and then drill a $7/16$ " hole on the pinch weld according to the mark.

CAUTION: Do not drill the hole too close to the bottom edge of the pinch weld.

VERY IMPORTANT! Be very careful and drill slowly through the pinch weld to avoid damaging the outer trim panel.

NOTE: Any cutting or drilling tool may break or shatter. Government regulations require safety glasses & equipment at all times when cutting or drilling.

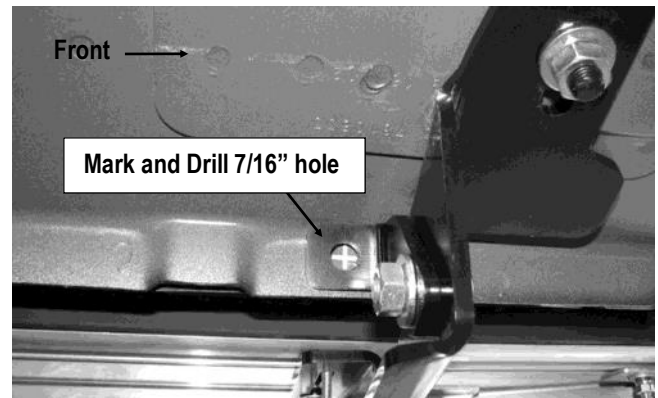

(Fig 11) Mark And Drill $7/16$ " Hole On Pinch Weld According To The Support Bracket Location

STEP 10

Select (1) Insert Installation Tool, (1) M8 Rivet Nut, (1) M8X1.25-25mm Hex Bolt and (1) M8 Flat Washer. Assemble the Insert Installation Tool as shown on Fig 13.

NOTE: Select 8 mm hole on threaded tool (Fig 12).

iArmor[®]

Hold the handle and push the M8 Rivet Nut into the drilled hole in the pinch weld. **NOTE:** Insert must fit snug in hole. If necessary, use a small hammer to carefully tap the Insert into the hole until the rim on the insert is flush against the pinch weld. Firmly hold the tool handle and tighten the Hex Bolt in the Tool to expand the M8 Rivet Nut in the hole. Continue until threads are pulled up close to the top of the Insert, (Figs 13A & 17). Remove the Tool and hardware. Bolt the Support Bracket to the M8 Rivet Nut with (1) M8x1-25mm Hex Bolt, (1) M8 Lock Washer and (1) M8 Large Flat Washer, (Fig 14). Do not fully tighten at this time.

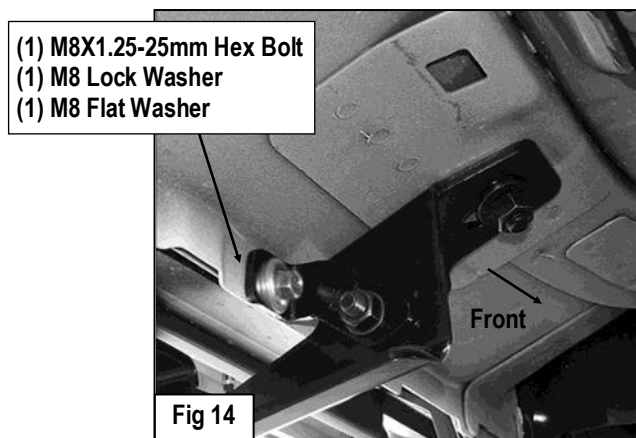
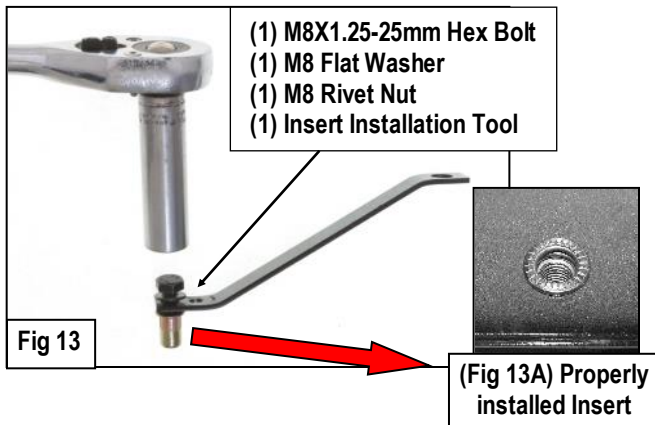

STEP 11

Move to the driver side rear Mounting Bracket. Hold the Driver Rear Support Bracket (DRS/PRS) firmly against the back of the pinch weld. Repeat Steps 9-10 to mark and drill the pinch weld and install the M8 Rivet Nut, (Figs 15 & 16). Reinstall the Support Bracket. Bolt the Support Bracket to the Insert with (1) M8X1-25mm Hex Bolt, (1) M8 Lock Washer and (1) M8 Large Flat Washer, (Fig 17). Tighten the front and rear Bracket hardware only at this time.

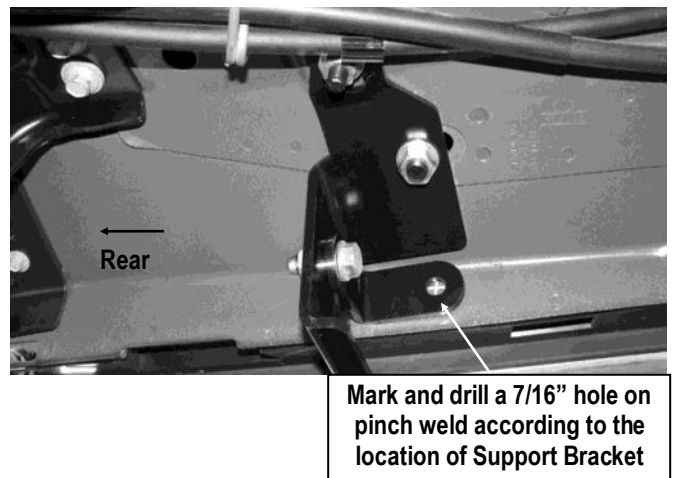

(Fig 15) Mark & Drill A Hole On The Pinch Weld According To The Driver Rear Support Bracket Location

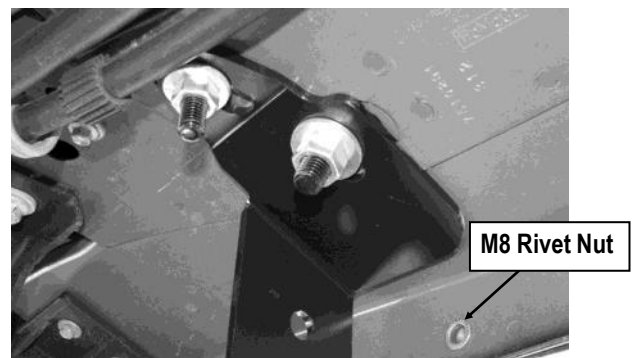

(Fig 16) M8 Rivet Nut Installed On Pinch Weld (Driver Rear Support Bracket Location)

iArmor[®]

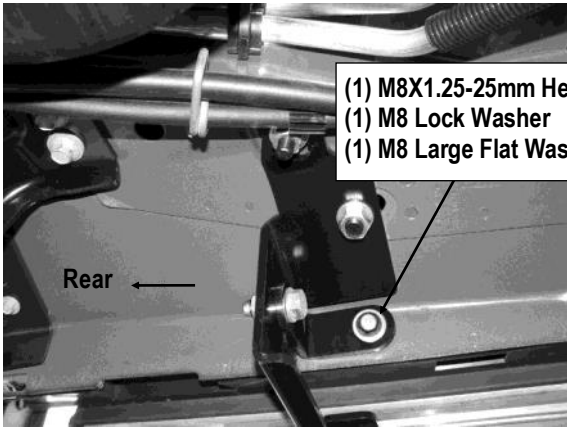

- (1) M8X1.25-25mm Hex Bolt
- (1) M8 Lock Washer
- (1) M8 Large Flat Washer

Rear ←

(Fig 17) Driver Rear Support Bracket Installed

STEP 12

Level and adjust the assembled Step Bar properly and tighten all hardware.

Move to the other side of the vehicle. Repeat **Steps 2-11** for the other Side Step Bar installation.

Attention

Do periodic inspections to the installation to make sure that all hardware is secure and tight.

In order to protect your bars/boards, please use mild soap/non-abrasive products for cleaning only.