

iArmor[®]

iArmor[®] by APS

PART#: IA-S178H

BEFORE INSTALLATION

REMOVE CONTENTS FROM BOX. VERIFY ALL PARTS ARE PRESENT. READ INSTRUCTIONS CAREFULLY BEFORE STARTING INSTALLATION. ASSISTANCE IS RECOMMENDED. THANK YOU FOR CHOOSING OUR PRODUCT!

*ROCKER PANEL MOUNT

*DRILLING MAYBE REQUIRED

Torque Value

Fastener Size	Tightening Torque (ft-lbs)	Required
6mm	6-7	√
8mm	16-18	√
10mm	31-32	X
12mm	56-58	X
14mm	92-94	X

PART LIST

Driver Side Step Bar

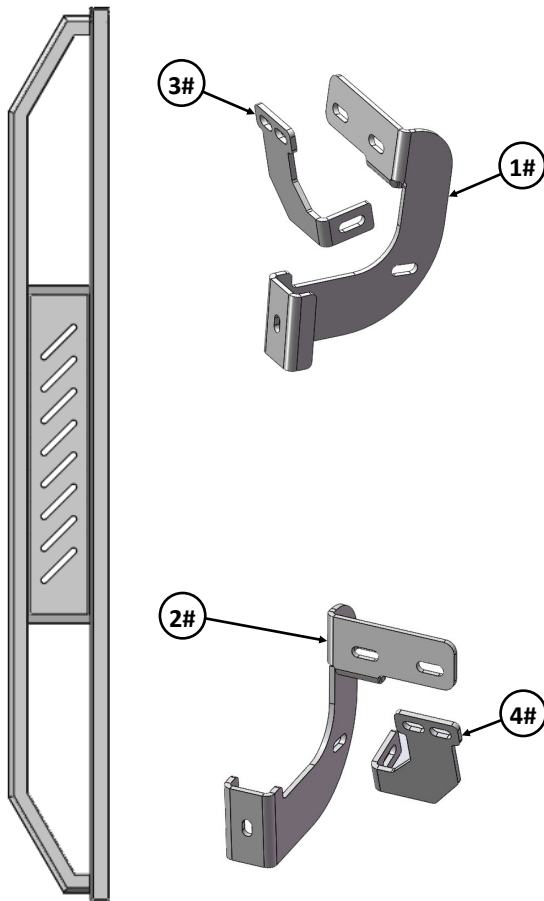

Front



Passenger Side Step Bar

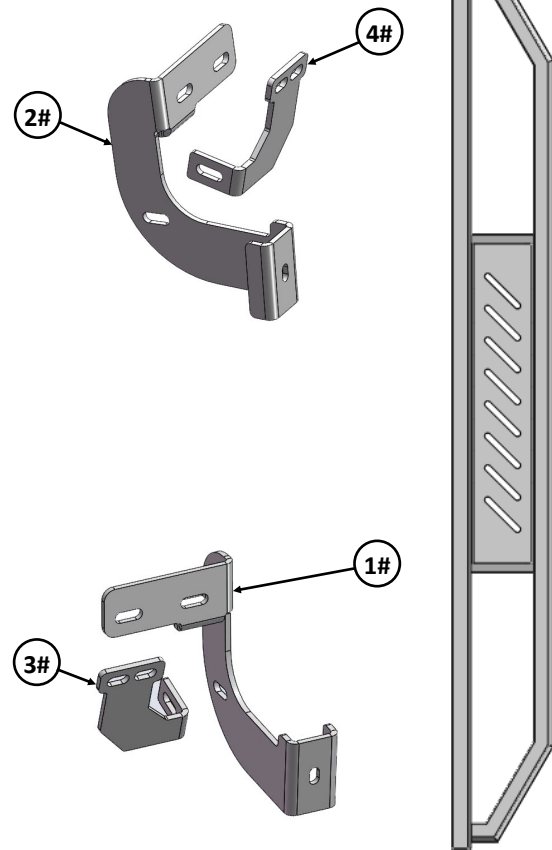

Customer Support: info@iarmorauto.com

iArmor®

Hardware Package A (For Bracket Installation)					
Item	QTY	Description	Item	QTY	Description
1#	2	Driver Front / Passenger Rear Mounting Brackets	9#	16	M8 Large Flat Washers
2#	2	Passenger Front / Driver Rear Mounting Brackets	10#	12	M8 Lock Washers
3#	2	Driver Front / Passenger Rear Support Brackets	11#	4	M8 Hex Nuts
4#	2	Passenger Front / Driver Rear Support Brackets	12#	4	M8X1.25 Nylon Lock Nuts
5#	4	U Brackets	13#	8	M6X1-25 Hex Bolts
6#	4	M8 Bolt/Nut Plates	14#	16	M6 Large Flat Washers
7#	4	M8 Plastic Washers	15#	8	M6X1 Nylon Lock Nuts
8#	12	M8X1.25-30 Hex Bolts			

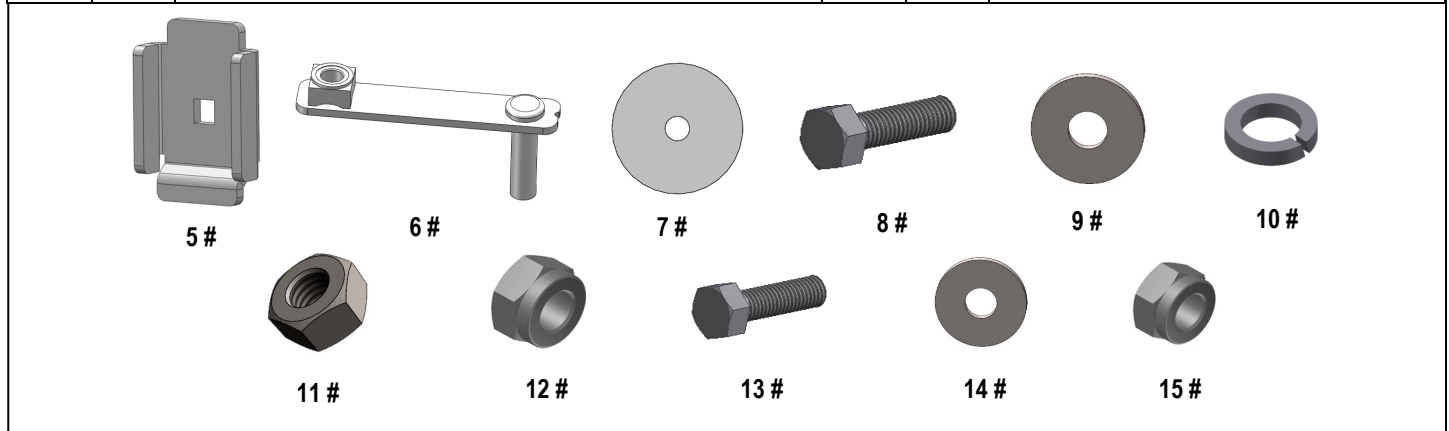

Hardware Package B (For Step Bar Installation)					
Item	QTY	Description	Item	QTY	Description
1#	4	M8X1.25-55mm Carriage Bolts	3#	4	M8 Lock Washers
2#	4	M8 Large Flat Washers	4#	4	M8 Hex Nuts

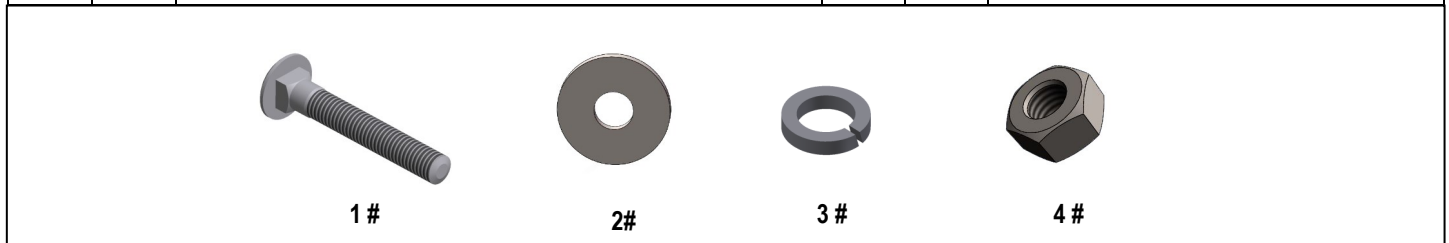

Customer Support: info@iarmorauto.com

iArmor®

The instruction here is for your reference only. We strongly recommend the professional installer for best result. We are not responsible for any damage caused by the installation.

STEP 1

Start the installation from the driver side front of the vehicle, remove the sealing tape covering the factory holes in the side of the inner panel, (Fig 1).

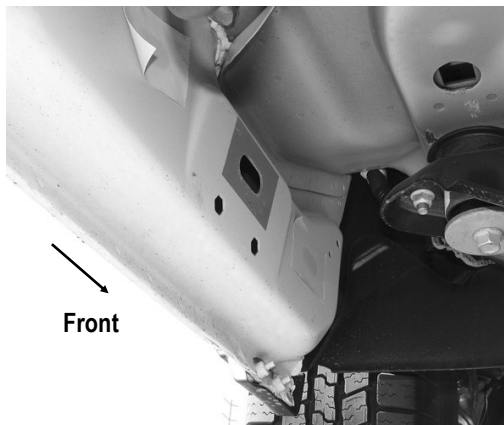

(Fig 1) 2009-Mid 2015 Driver Side Front Mounting Location (No Factory Holes In Pinch Weld on Some Models)

STEP 2

Determine the correct procedure to attach one driver side Bracket for your model/year:

Models without factory threaded inserts in body panel:

- a. Select (1) M8 Bolt/Nut Plate (Fig 2). Partially thread (1) M8X1.25-30mm Hex Bolt in the Welded nut on the Bolt/Nut Plate until it is flush with the welded nut, (Fig 3). Use the Hex Bolt as a handle and insert the Bolt/Nut Plate into the oval hole, (Fig 4). Feed the threaded bolt on the Bolt Plate through one of the hex factory holes. Thread (1) M8 Plastic Washer onto the welded bolt and down tight against the body panel, (Fig 5).

NOTE: The Plastic Washer is designed to keep the Bolt/Nut Plate out of falling into the body panel and to aid in Bracket installation.

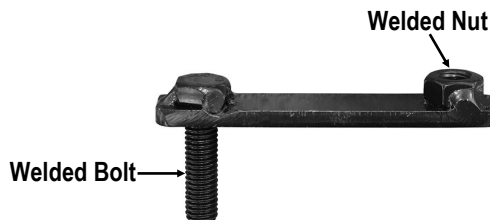

(Fig 2) M8 Bolt/Nut Plate (NOTE: M8 Bolt/Nut Plate Is Not Required On Models With Factory Threaded Inserts)

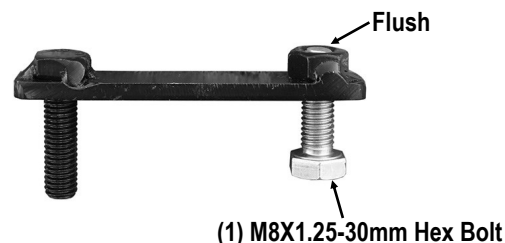

(Fig 3) Thread (1) M8 Hex Bolt Into The Nut On The Plate. Stop When Bolt Reaches End Of Nut As Pictured

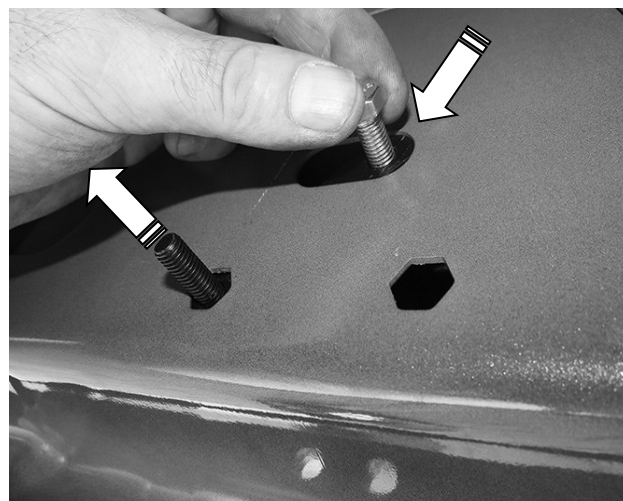

(Fig 4) Use The Loose Hex Bolt As A Handle. Insert The M8 Bolt/Nut Plate Into The Oval Hole And Feed The Welded Bolt End Out Either Factory Hex Hole on Body Panel.

iArmor®



Remove M8X1.25-30mm Hex Bolt After M8 Plastic Washer installed

M8 Plastic Washer

(Fig 5) Thread Plastic Washer Onto the Welded Bolt on M8 Bolt/Nut Plate To Hold Bolt/Nut Plate In Position.

IMPORTANT: Do Not Remove The Hex Bolt Until The M8 Plastic Washer Has Been Threaded Onto the Welded Bolt.

b. Select (1) Driver Front Mounting Bracket. Attach the mounting bracket to the welded bolt end of the M8 Bolt/Nut Plate with (1) M8 Large Flat Washer, (1) M8 Lock Washer and (1) M8X1.25 Hex Nut, (Fig 6A). Do not fully tighten at this time.

Hold the welded bolt on the M8 Bolt/Nut Plate and rotate the Bolt/Nut Plate until the welded nut lines up with the remaining hex hole on the body panel.

(1) M8 Large Flat Washer
(1) M8 Lock Washer
(1) M8X1.25 Hex Nut

Rotate M8 Bolt/Nut Plate To Line Up the Welded Nut With the Hex Hole on Body Panel (See Arrow)

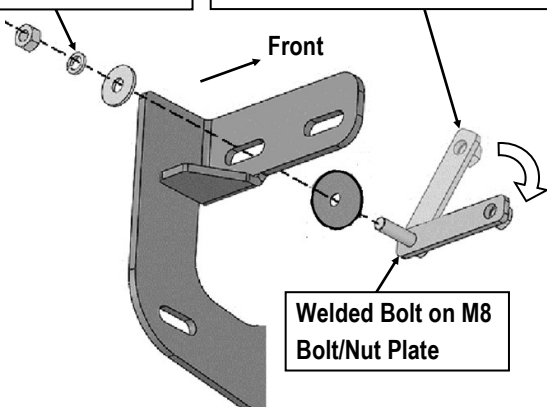

(Fig 6A) Attach Driver Front Mounting Bracket To the Welded Bolt on M8 Bolt/Nut Plate

c. Secure the Driver Front Mounting Bracket to the welded nut on the M8 Bolt/Nut Plate with (1) M8x1.25- 30mm Hex Bolt, (1) M8 Lock Washer and (1) M8 Large Flat Washer, (Fig 6B). Do not fully tighten hardware at this time.

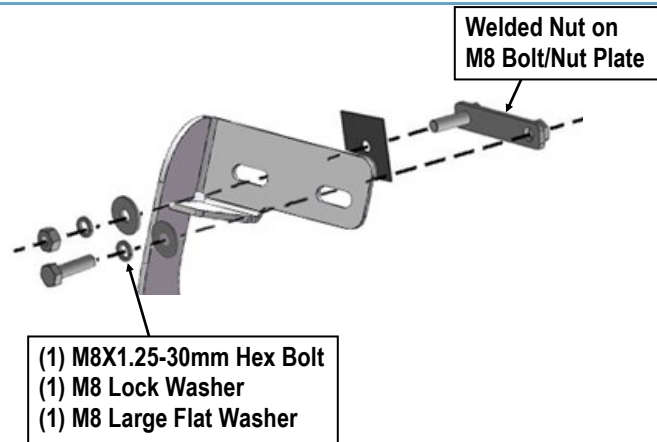

(Fig 6B) Secure Driver Front Mounting Bracket To the Welded Nut on M8 Bolt/Nut Plate

Models with factory threaded inserts:

Attach Driver Front Mounting Bracket to the threaded inserts with (2) M8x1.25-30mm Hex Bolts, (2) M8 Lock Washers and (2) M8 Large Flat Washers, (Figs 7 & 8). Leave hardware loose.

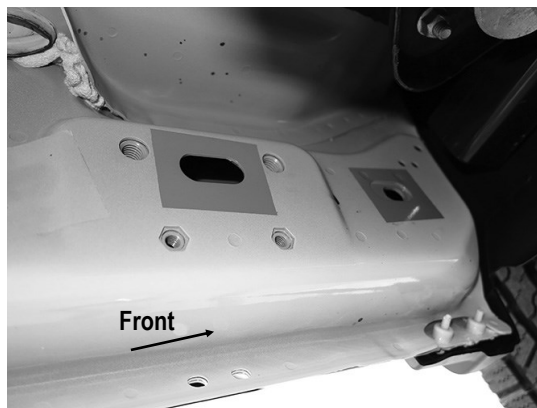

(Fig 7) Driver Side Front Mounting Location (Mid 2015-On, An Example Of Models With Factory Threaded Inserts)

iArmor®

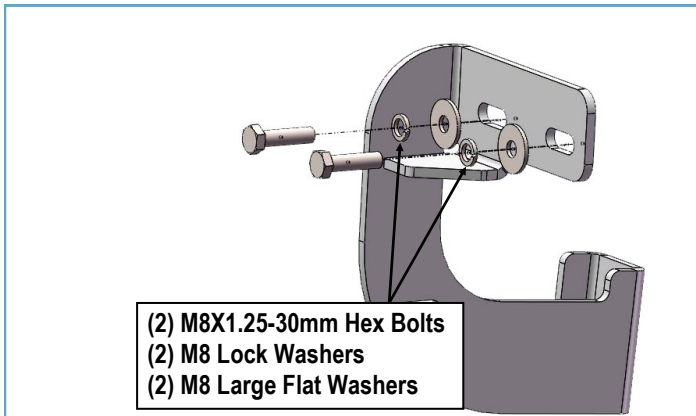

(Fig 8) Driver Front Mounting Bracket Installed (For Models With Factory Threaded Inserts. Bolt Plate Not Required)

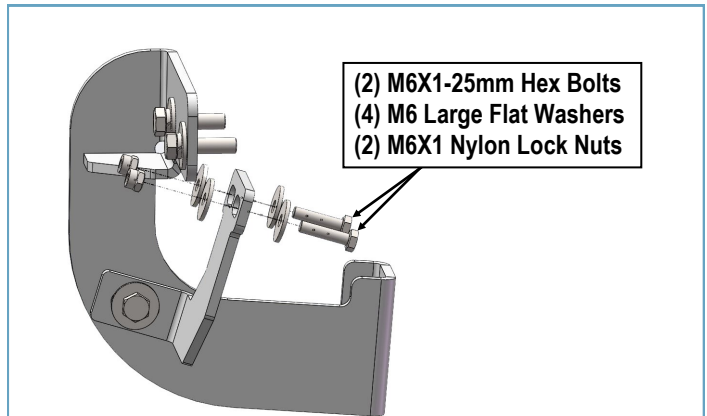

(Fig 10A) Attach Driver Front Support Bracket To the Back Of The Pinch Weld (Models With Factory Holes In Pinch Weld Only)

STEP 3

Attach the Driver Front Support Bracket to the Driver Front Mounting Bracket with (1) M8X1.25-30mm Hex Bolt, (2) M8 Large Flat Washers and (1) M8X1.25 Nylon Lock Nut, (Fig 9). Rotate the support bracket to the back of the pinch weld. Line up the slots in the top of the Support Bracket with the (2) factory holes in the pinch weld. Attach the support bracket to the back of the pinch weld with (2) M6x1-25mm Hex Bolts, (4) M6 Large Flat Washers and (2) M6X1 Nylon Lock Nuts, (Fig 10A & 10B). Do not fully tighten hardware at this time.

IMPORTANT: Some models are not equipped with factory holes and will require drilling through the pinch weld to attach the Support Bracket. Do not drill through pinch weld at this time, (Refer to Step 7).

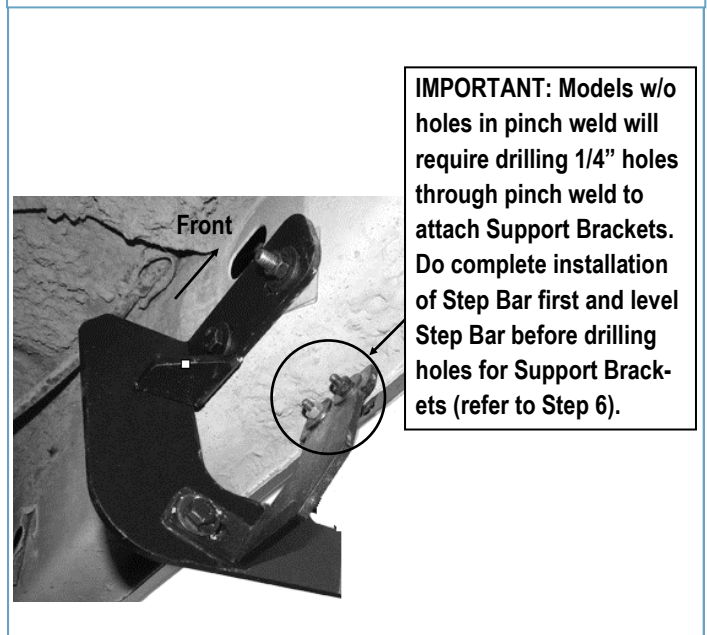

(Fig 10B) Driver Front Brackets installed

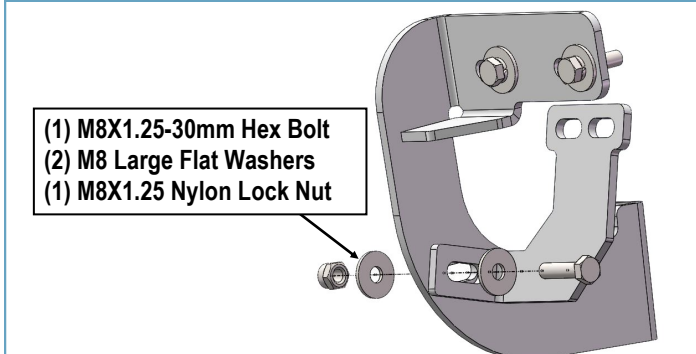

(Fig 9) Attach Driver Front Support Bracket To Front Facing Side Of the Driver Front Mounting Bracket

STEP 4

Move along the side of the body panel to the Driver Side Rear Mounting Location, (Fig 11). Repeat Steps 2-3 to install the driver side rear Brackets, (Figs 12A & 12B).

iArmor®

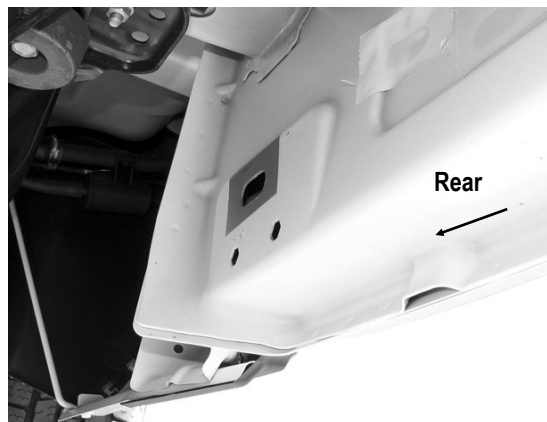

(Fig 11) Driver Side Rear Mounting Location

(2) M8X1.25-30mm Hex Bolts
(2) M8 Lock Washers
(2) M8 Large Flat Washers

(2) M6X1-25mm Hex Bolts
(4) M6 Large Flat Washers
(2) M6X1 Nylon Lock Nuts

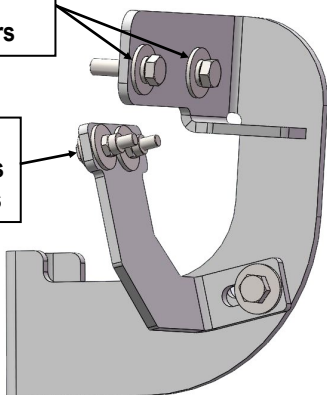

(Fig 12A) Driver Rear Brackets Installed



(Fig 12B) Driver Rear Brackets installed

STEP 5

Once all (2) driver side mounting brackets are installed, select and attach the Driver Side Step Bar onto the Mounting Brackets with (2) U Brackets, (2) M8X1.25-55mm Carriage Bolts, (2) M8 Large Flat Washers, (2) M8 Lock Washers and (2) M8X1.25 Hex Nuts (Fig 13). Do not fully tighten hardware at this time.

STEP 6

Properly level and adjust the Step Bar and fully tighten all hardware.

STEP 7

Properly level and adjust the Step Bar and fully tighten all hardware.

Models requiring drilling for driver side Support Brackets:

- Make sure the Step Bar is level to the vehicle. Adjust and tighten all mounting hardware.
- Line up the slots on the Support Brackets with the back of the pinch weld. Mark the location of the slots onto the pinch weld.
- Drill (2) 1/4" holes through the pinch weld for each Support Bracket. **IMPORTANT:** Do not drill too close to the bottom edge of the pinch weld. Adjust the Brackets as necessary to move the slots up the body panel away from the edge. Drill the holes toward the outside of the marked slots.
- Attach each Support Brackets to the pinch weld with (2) M6X1-25mm Hex Bolts, (4) M6 Large Flat Washers and (2) M6X1 Nylon Lock Nuts, (Figs 10 & 12). Check for level then fully tighten all hardware.

STEP 8

Move to the passenger side of the vehicle. Repeat **Steps 1-7** to install the passenger side step bar. Installation completed.

iArmor®

NOTE: Torque all M8 X1.25-55mm Carriage Bolts to 16~18 lb-ft. Don't over tighten, or the square bars will be damaged by the brackets

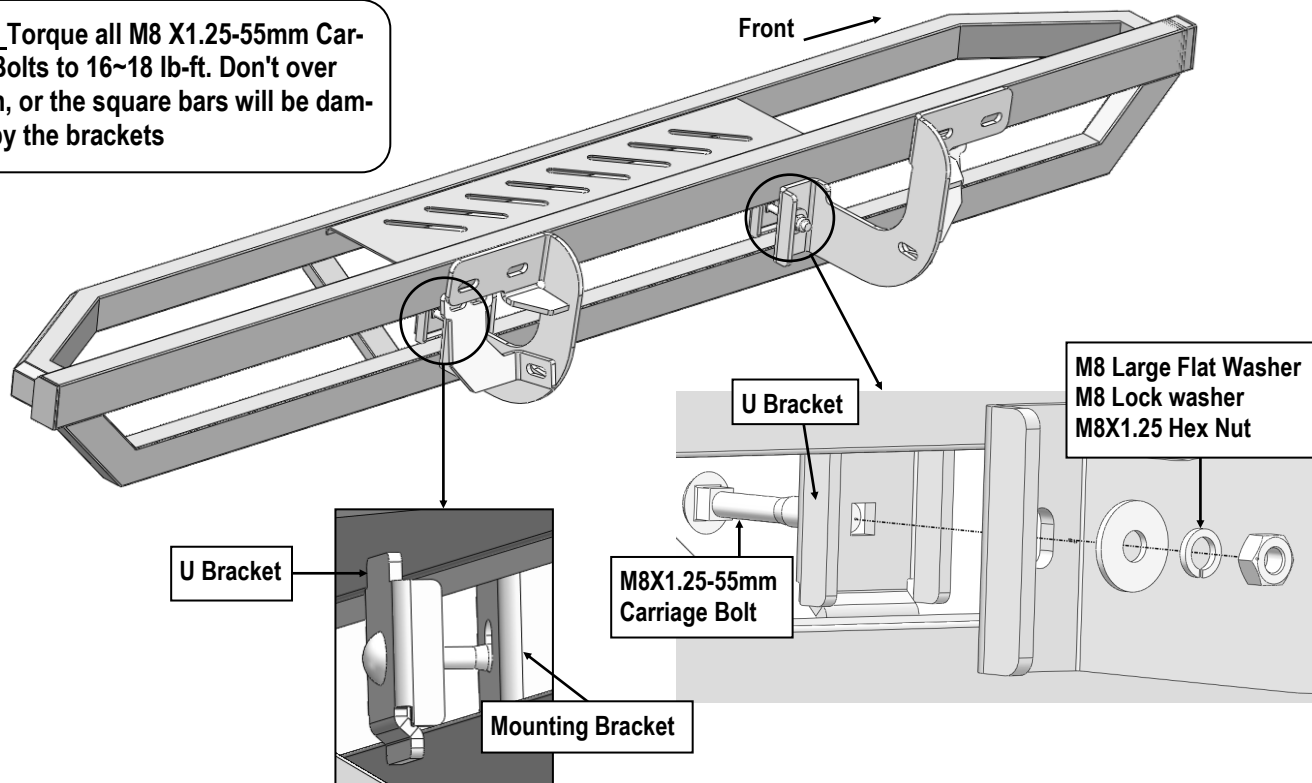

(Fig 13) Driver Side Step Bar Installation

Attention

Do periodic inspections to the installation to make sure that all hardware is secure and tight.
In order to protect your bars/boards, please use mild soap/non-abrasive products for cleaning only.