

iArmor®

IARMOR EDGE™

PART#: IA-N022H

BEFORE INSTALLATION

REMOVE CONTENTS FROM BOX. VERIFY ALL PARTS ARE PRESENT. READ INSTRUCTIONS CAREFULLY BEFORE STARTING INSTALLATION. ASSISTANCE IS RECOMMENDED. THANK YOU FOR CHOOSING OUR PRODUCT!

*ROCKER PANEL MOUNT

*DRILLING NOT REQUIRED

Torque Value

Fastener Size	Tightening Torque (ft-lbs)	Required
6mm	6-7	X
8mm	16-18	√
10mm	31-32	X
12mm	56-58	X
14mm	92-94	X

PART LIST

Driver Side Step Bar

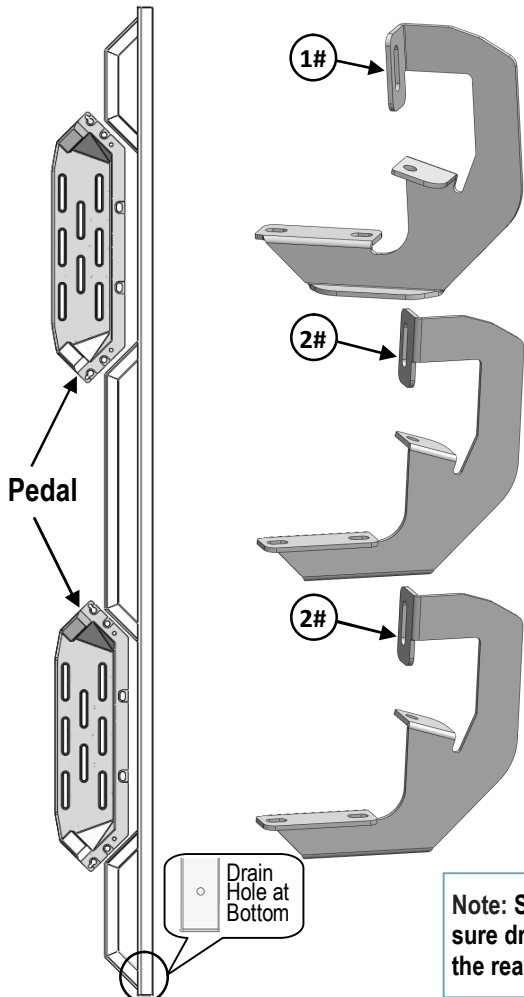

Front





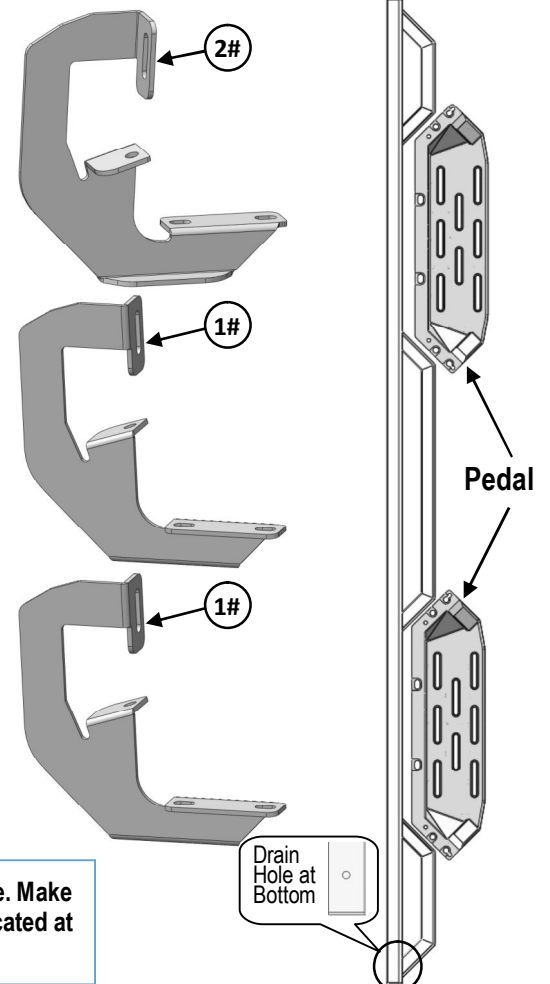



Passenger Side Step Bar





Note: Step bars are NOT interchangeable. Make sure drain holes at the bottom will be located at the rear direction of the step bars.

iArmor®

Hardware Package A (For Brackets & Bars Installation)					
Item	QTY	Description	Item	QTY	Description
1#	3	Driver Front / Passenger Center / Rear Mounting Brackets	6#	12	M8 Hex Nuts
2#	3	Passenger Front / Driver Center / Rear Mounting Brackets	7#	12	M8X1.25-20 T Bolts
3#	12	M8X1.25-20 Hex Bolts	8#	12	M8 Plastic Washers
4#	30	M8 Large Flat Washers	9#	12	M8 Nylon Lock Nuts
5#	12	M8 Lock Washers			

						
3#	4#	5#	6#	7#	8#	9#

Hardware Package B (For Step Pedals Installation)					
Item	QTY	Description	Item	QTY	Description
1#	24	M8X1.25-25 Hex Bolts	3#	24	M8 Lock Washers
2#	24	M8 Large Flat Washers			

		
1#	2#	3#

iArmor®

The instruction here is for your reference only. We strongly recommend the professional installer for best result. We are not responsible for any damage caused by the installation.

STEP 1

Install (4) Pedals onto the step bars with (24) M8X1.25-25mm Hex Bolts, (24) M8 Large Flat Washers and (24) M8 Lock Washers.

IMPORTANT: Don't punch the pedal with any metal hammer within pedal installation, or the pedal will be damaged.

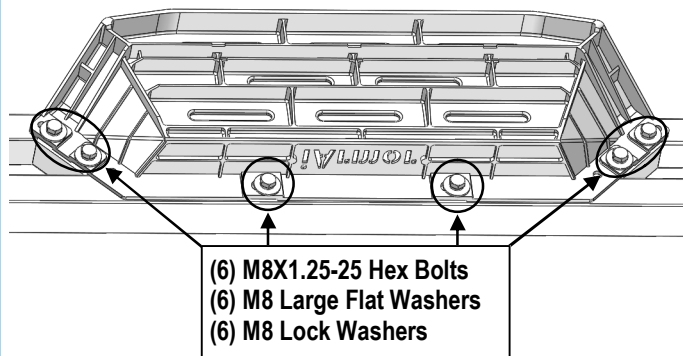

STEP 2

Start installation from the driver side front of the vehicle. Locate the factory threaded hole or stud located on the inner body panel, and (1) hole on the pinch weld, (**Fig 1**). Remove the plastic plug or any insulation on the side panel to locate the threaded holes if equipped.

NOTE: It will be helpful for identifying the mounting holes to hold up a mounting bracket in place.

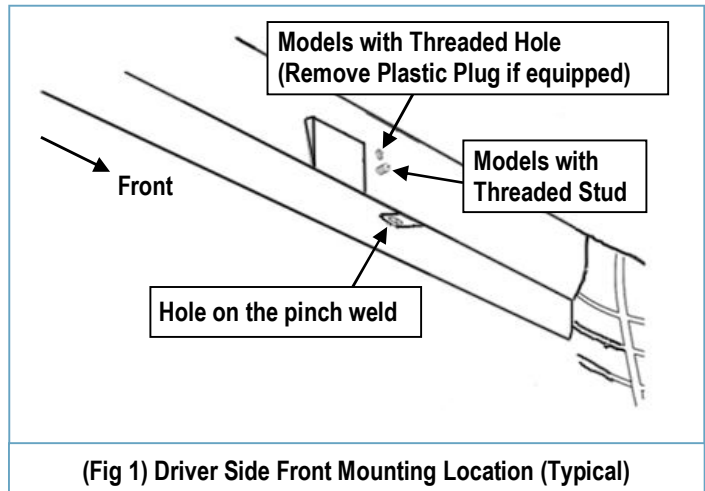

STEP 3

Select (1) Driver Front Mounting Bracket. Install the Bracket as shown in (**Fig 2**). Do not fully tighten hardware at this time.

Note: Driver Front and Passenger Center/ Rear Mounting Bracket are the same.

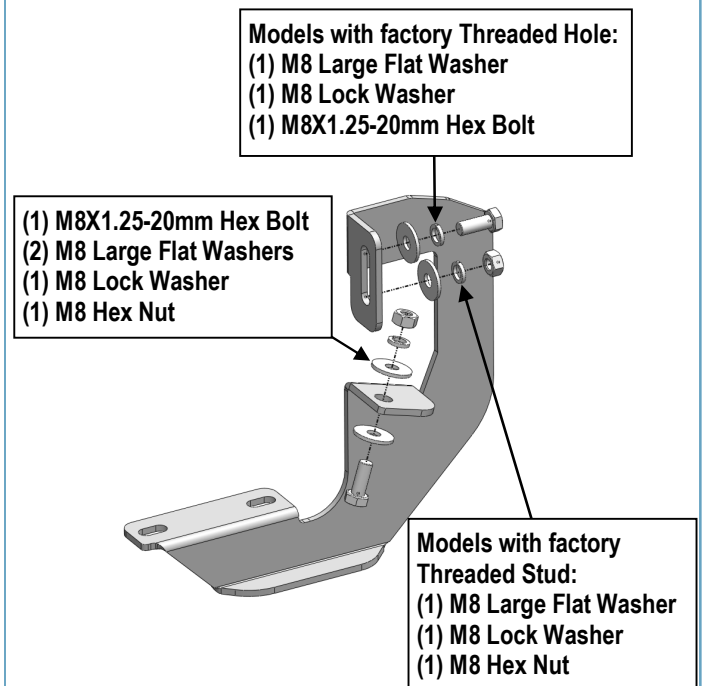

(Fig 2) Driver Front Mounting Bracket Installation

iArmor[®]

STEP 4

Move to the driver side center & rear mounting locations of the vehicle. Repeat **Step 3** to install the Driver Center & Rear Mounting Bracket. Do not fully tighten hardware at this time.

STEP 5

Once all (3) brackets have been installed, select (6) M8X1.25-20mm T-Bolts, thread (1) M8 Plastic Washer on each T-Bolt, (**Fig 3**). Install the (6) M8X1.25-20mm T-Bolts with plastic washers in the slots on the assembled Driver side step bar. Rotate the T-Bolts to 90 degree, thread down the M8 Plastic Washers against the step bar (**Fig 4**).

NOTE: The Plastic Washer is designed to keep the T-Bolt in place to avoid falling into the tube during installation.

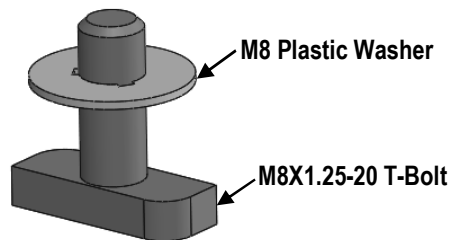

(Fig 3) Thread (1) M8 Plastic Washer on each T-Bolt Before Inserting into the slot !!!

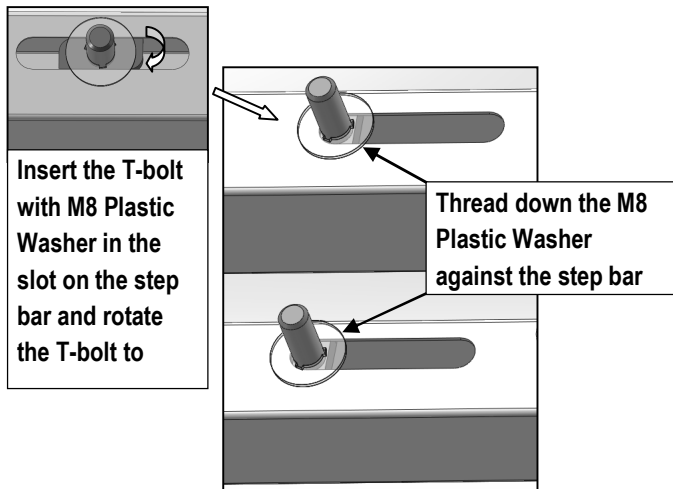

(Fig 4) T-Bolt with plastic washer in the slot

STEP 6

Attach the Assembled Driver Side Step Bar onto the Mounting Brackets with (6) M8 Plastic Washers, (6) M8X1.25-20mm T-Bolts, (6) M8 Large Flat Washers, (6) M8 Nylon Lock Nuts, (**Fig 5**). Do not fully tighten hardware at this time.

STEP 7

Level and adjust the assembled Step Bar properly and tighten all hardware.

Move to the other side of the vehicle. Repeat **Steps 2-6** for the other side step bar installation.

Attention

Do periodic inspections to the installation to make sure that all hardware is secure and tight.

In order to protect your bars/boards, please use mild soap/non-abrasive products for cleaning only.

iArmor[®]

(Fig 5) Driver Side Step Bar Installation

