



Hitch Installation Instruction

REV.20240601

Part#	HT-X30416	Application	For 2019-2023 Toyota RAV4					
-------	-----------	-------------	---------------------------	--	--	--	--	--

Hardware List	Item	Part Name	QTY	Description	Item	Part Name	QTY	Description
Hitch Parts	A	Hitch Body	1		B/C	Mounting Brackets	2	B-Driver Side C-Passenger Side
HW B (For Hitch Installation)	1	Hex Bolts	4	M12X1.25-35	2	Conical Washers	4	M12
HW A (For Hitch Assembly)	3	Hex Bolts	8	M12X1.75-35	5	Hex Flange Nuts	8	M12
	4	Flat Washers	16	M12				

Gross Load Capacity When Used As A Weight Carrying Hitch: 4000 LBS. Trailer Weight & 600 LBS. Tongue Weight.
 Gross Load Capacity When Used As A Weight Distribution Hitch: 4000 LBS. Trailer Weight & 600 LBS. Tongue Weight.
*****DO NOT EXCEED VEHICLE MANUFACTURER'S RECOMMENDED TOWING CAPACITY.*****

- * No Trimming Required
- * No Drilling Required

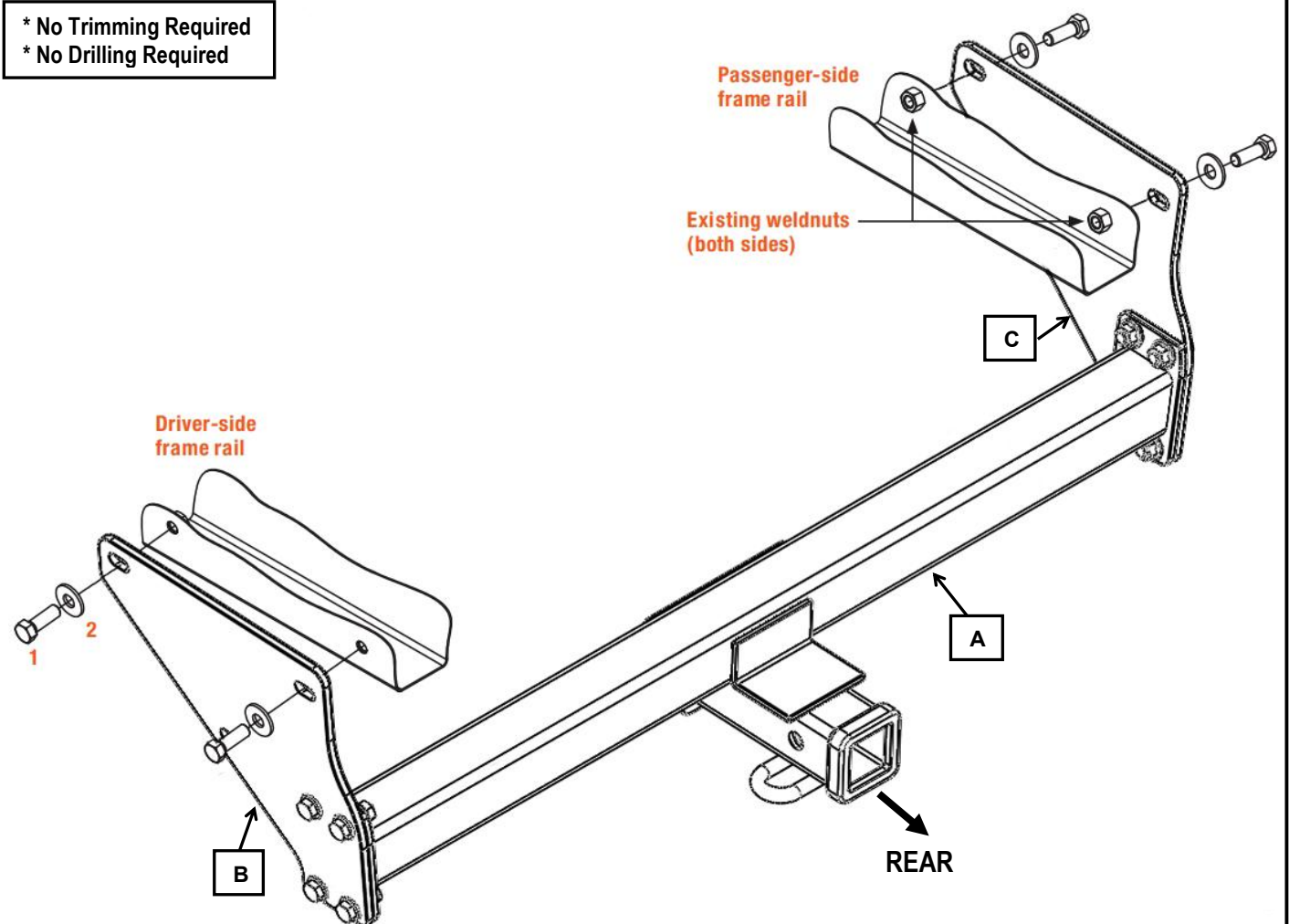

WELDNUT CLEANING

To remove debris from weldnuts in frame, spray lubricant or compressed air into hole. For heavy debris, use a small wire brush. (Be careful not to damage threads).

CONICAL TOOTHED WASHER ORIENTATION

The instruction here is for your reference only. We strongly recommend the professional installer for best result. We are not responsible for any damage caused by the installation. Thank you for choosing our product!



Hitch Installation Instruction

Part#	HT-X30416	Application	For 2019-2023 Toyota RAV4
-------	-----------	-------------	---------------------------

Step	Description
1	Assemble Hitch Body (A) and Mounting Brackets (B, C) with (8) M12X1.75-35mm Hex Bolts, (16) M12 Flat Washers, (8) M12 Hex Flange Nuts.(Hardware in "HW A").
2	Remove any stickers covering the holes on the outside of the frame rails. If equipped, remove the tie down bracket from the bottom of the passenger-side frame rail and return it to the vehicle owner.



3	Raise the trailer hitch into position and loosely secure with the provided hardware (#1, #2). Torque all M12 hardware to 86 ft-lbs.
---	--

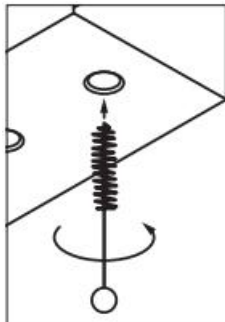

WELDNUT CLEANING

To remove debris from weldnuts in frame, spray lubricant or compressed air into the hole.
For heavy debris, use a wire brush. Take care not to damage threads.

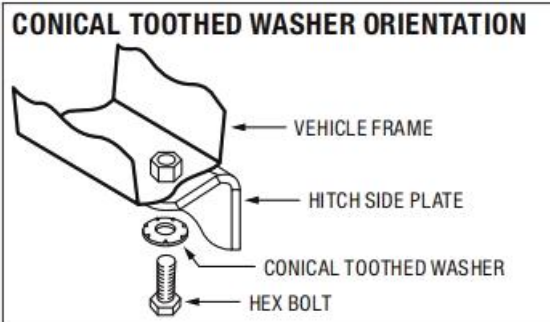

4	Installation Complete.
---	------------------------

*****Periodically Check The Receiver Hitch To Ensure That All Fasteners ***
Are Tight & All Structural Components Are Sound.**

The instruction here is for your reference only. We strongly recommend the professional installer for best result. We are not responsible for any damage caused by the installation. Thank you for choosing our product!