



Hitch Installation Instruction

REV.20240601

Part#	HT-X30382	Application	For 2018-2024 Subaru Crosstrek Excluding Hybrid
-------	-----------	-------------	---

Hardware List	Item	Part Name	QTY	Description	Item	Part Name	QTY	Description
Hitch Parts	A	Hitch Body	1		B/C	Mounting Brackets	2	B-Driver Side C-Passenger Side
	HW B (For Hitch Installation)	1	Carriage Bolts	4	M12X1.75-40	4	Hex Flange Nuts	4
2		Spacers	4	With SQ Hole	5	Fishwires	4	
3		Spacers	2	With Round Hole				
HW A (For Hitch Assembly)	6	Hex Bolts	8	M12X1.75-35	8	Hex Flange Nuts	8	M12
	7	Flat Washers	16	M12				

Gross Load Capacity When Used As A Weight Carrying Hitch: 3500 LBS. Trailer Weight & 525 LBS. Tongue Weight.
*****DO NOT EXCEED VEHICLE MANUFACTURER'S RECOMMENDED TOWING CAPACITY.*****

- * No Trimming Required
- * No Drilling Required

FISHWIRE TECHNIQUE

INSERT COILED END OF FISHWIRE TOOL THROUGH HITCH MOUNTING HOLE IN VEHICLE FRAME RAIL AND OUT THE ACCESS HOLE. PASS COILED END OF FISHWIRE THROUGH SPACER AND THREAD BOLT INTO COIL. KINK WIRE TO KEEP SPACER SEPARATE FROM BOLT AS SHOWN. PULL FISHWIRE, SPACER, AND BOLT THROUGH FRAME AND OUT MOUNTING HOLE. USE FISHWIRE TO GUIDE HITCH DURING MOUNTING AND PREVENT LOSS OF BOLT / SPACER INSIDE FRAME RAIL.

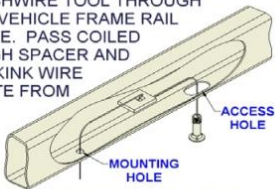

NOTE: SOME VEHICLES MAY FISHWIRE THROUGH END OF FRAME

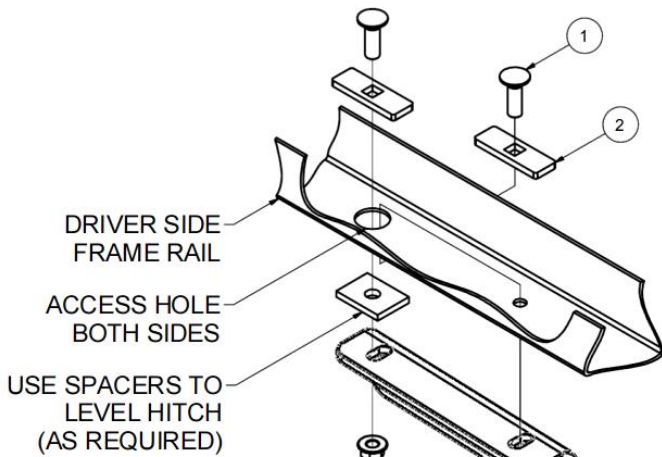
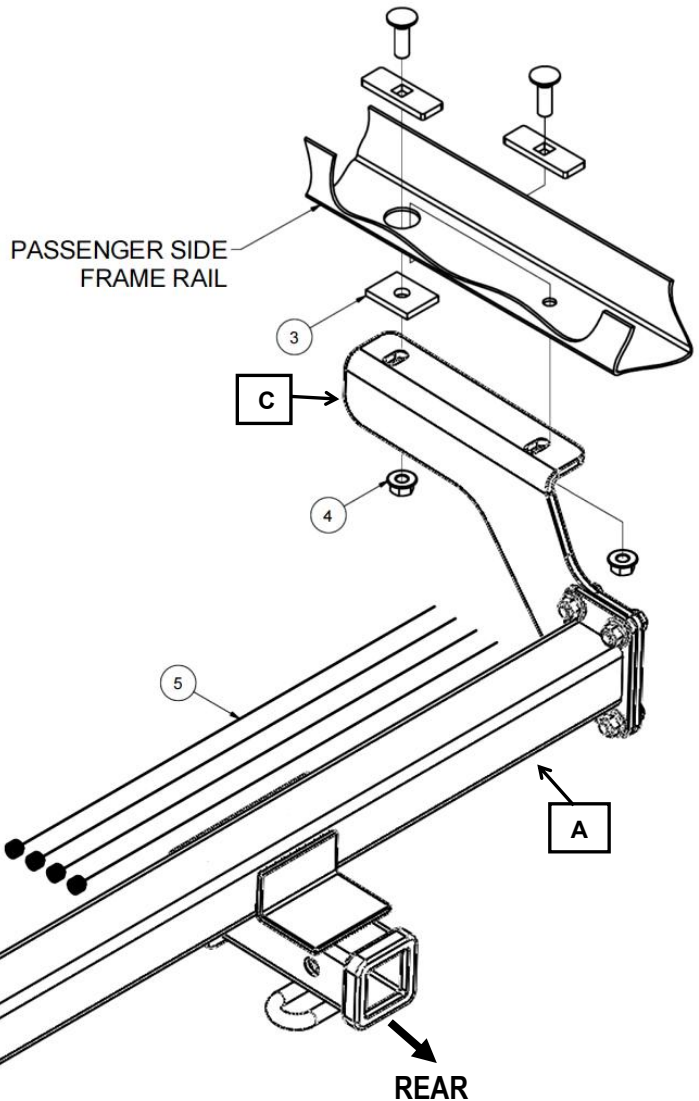

REVERSE PULL FISHWIRE TECHNIQUE



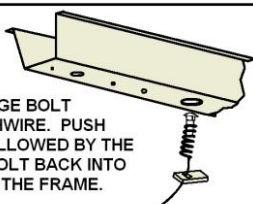



ATTACH FISHWIRE TO CARRIAGE BOLT AND SLIDE SPACER ONTO FISHWIRE. PUSH THE BOLT THRU THE HOLE FOLLOWED BY THE SPACER (AS SHOWN). PULL BOLT BACK INTO POSITION, PROTRUDING FROM THE FRAME.



The instruction here is for your reference only. We strongly recommend the professional installer for best result. We are not responsible for any damage caused by the installation. Thank you for choosing our product!



Hitch Installation Instruction

Part#	HT-X30382	Application	For 2018-2024 Subaru Crosstrek Excluding Hybrid
Step	Description		
1	Assemble Hitch Body (A) and Mounting Brackets (B, C) with (8) M12X1.75-35mm Hex Bolts, (16) M12 Flat Washers, (8) M12 Hex Flange Nuts.(Hardware in "HW A").		
2	Remove (2) rubber plugs from each frame rail and return to vehicle owner (leave center plugs in the frame).		
			
3	Enlarge access holes and fishwire M12 carriage bolts and spacers into position and reverse fishwire remaining M12 carriage bolts and SQ spacers into access hole. Leave fishwires attached.		
			
4	Raise hitch into position using round spacers to level hitch as necessary. Remove fishwires and loosely install (4) M12X1.75 hex flange nuts. NOTE: Be careful not to push the bolts into the frame.		
			
5	Torque all M12 fasteners to 58 lb-ft.		
			
***Periodically Check The Receiver Hitch To Ensure That All Fasteners *** Are Tight & All Structural Components Are Sound.			

The instruction here is for your reference only. We strongly recommend the professional installer for best result. We are not responsible for any damage caused by the installation. Thank you for choosing our product!