



# Hitch Installation Instruction

REV.20240601

<b>Part#</b>	HT-X30204	<b>Application</b>	For 2008-2020 Nissan Rogue (Excluding Krom) / 2014-2015 Nissan Rogue Select All					
--------------	-----------	--------------------	---	--	--	--	--	--

Hardware List	Item	Part Name	QTY	Description	Item	Part Name	QTY	Description
<b>Hitch Parts</b>	A	Hitch Body	1		B/C	Mounting Brackets	2	B-Driver Side C-Passenger Side
<b>HW B (For Hitch Installation)</b>	1	Hex Bolts	5	M12X1.25-35	2	Conical Washer	5	M12
<b>HW A (For Hitch Assembly)</b>	3	Hex Bolts	8	M12X1.75-35	5	Hex Flange Nuts	8	M12
	4	Flat Washers	16	M12				

Gross Load Capacity When Used As A Weight Carrying Hitch: 3500 LBS. Trailer Weight & 525 LBS. Tongue Weight.  
**\*\*\*DO NOT EXCEED VEHICLE MANUFACTURER'S RECOMMENDED TOWING CAPACITY.\*\*\***

**No Drilling Required**

### RUBBER ISOLATOR REMOVAL DIAGRAM

This technique can be used if and Exhaust Hanger Removal Pliers is not available.

Using a 5/8" open end wrench, slide the wrench up to the rubber isolator, cradling the hanger rod as shown. Next place the flat edge of a pry bar between the wrench and the hanger stop or hanger rod. Then simply rotate the pry bar toward the wrench to remove the rubber isolator.

Note: Using a spray lubricant or soapy water on the hanger rod and the rubber isolator helps removal.

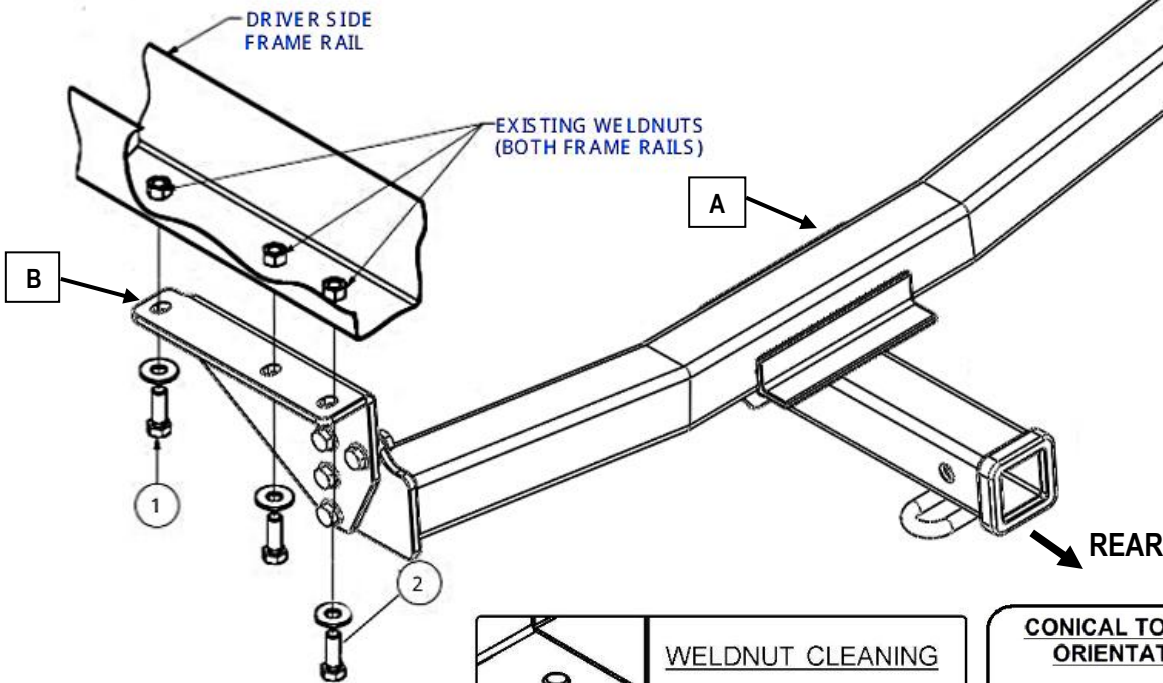
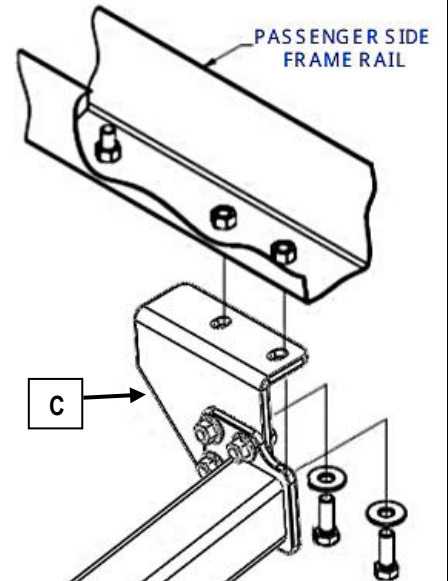
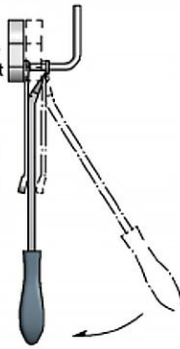

### WELDNUT CLEANING

To remove debris from weldnuts in frame, spray lubricant or compressed air into hole. For heavy debris, use a small wire brush. (Be careful not to damage threads).

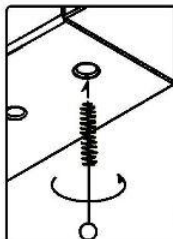

### CONICAL TOOTHED WASHER ORIENTATION DIAGRAM

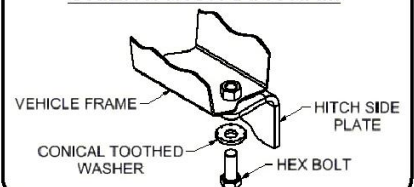

The instruction here is for your reference only. We strongly recommend the professional installer for best result. We are not responsible for any damage caused by the installation. Thank you for choosing our product!



# Hitch Installation Instruction

REV.20240601

Part#	HT-X30204	Application	For 2008-2020 Nissan Rogue (Excluding Krom) / 2014-2015 Nissan Rogue Select All
Step	Description		
1	Assemble Hitch Body (A) and Mounting Brackets (B, C) with (8) M12X1.75-35mm Hex Bolts, (16) M12 Flat Washers, (8) M12 Hex Flange Nuts.(Hardware in "HW A").		
2	Remove lower under-body panels, if present, using a small screwdriver and Phillips head screwdriver and return to vehicle owner.		
3	Remove tow hook / bracket from the passenger side frame rail (4-5 bolts) and return to vehicle owner.		
4	Lower exhaust for ease of installation.		
5	Raise hitch into position and secure with hex bolts and conical washers as shown in the diagram above.		
6	Torque all M12 fasteners to 86 lbs-ft.		
7	Reinstall exhaust, if removed in Step 3.		
<b>***Periodically Check The Receiver Hitch To Ensure That All Fasteners *** Are Tight &amp; All Structural Components Are Sound.</b>			

The instruction here is for your reference only. We strongly recommend the professional installer for best result. We are not responsible for any damage caused by the installation. Thank you for choosing our product!