



Hitch Installation Instruction

REV.20240501

Part#	HT-R30315	Application	For 2013-2024 Mazda CX-5 Excluding Diesel
-------	-----------	-------------	---

Hardware List	Item	Part Name	QTY	Description	Item	Part Name	QTY	Description
	1	Hex Bolts	3	M12X1.75-40	5	Conical Washers	3	M12
	2	Carriage Bolts	2	M12X1.75-40	6	Spacers	2	With SQ hole
	3	Hex Flange Nuts	2	M12X1.75	7	Fishwires	2	
	4	Flat Washers	4	M12	8	Cable Tie	2	

Gross Load Capacity When Used As A Weight Carrying Hitch: 4000 LBS. Trailer Weight & 600 LBS. Tongue Weight.
*****DO NOT EXCEED VEHICLE MANUFACTURER'S RECOMMENDED TOWING CAPACITY.*****

- * No Trimming Required
- * No Drilling Required

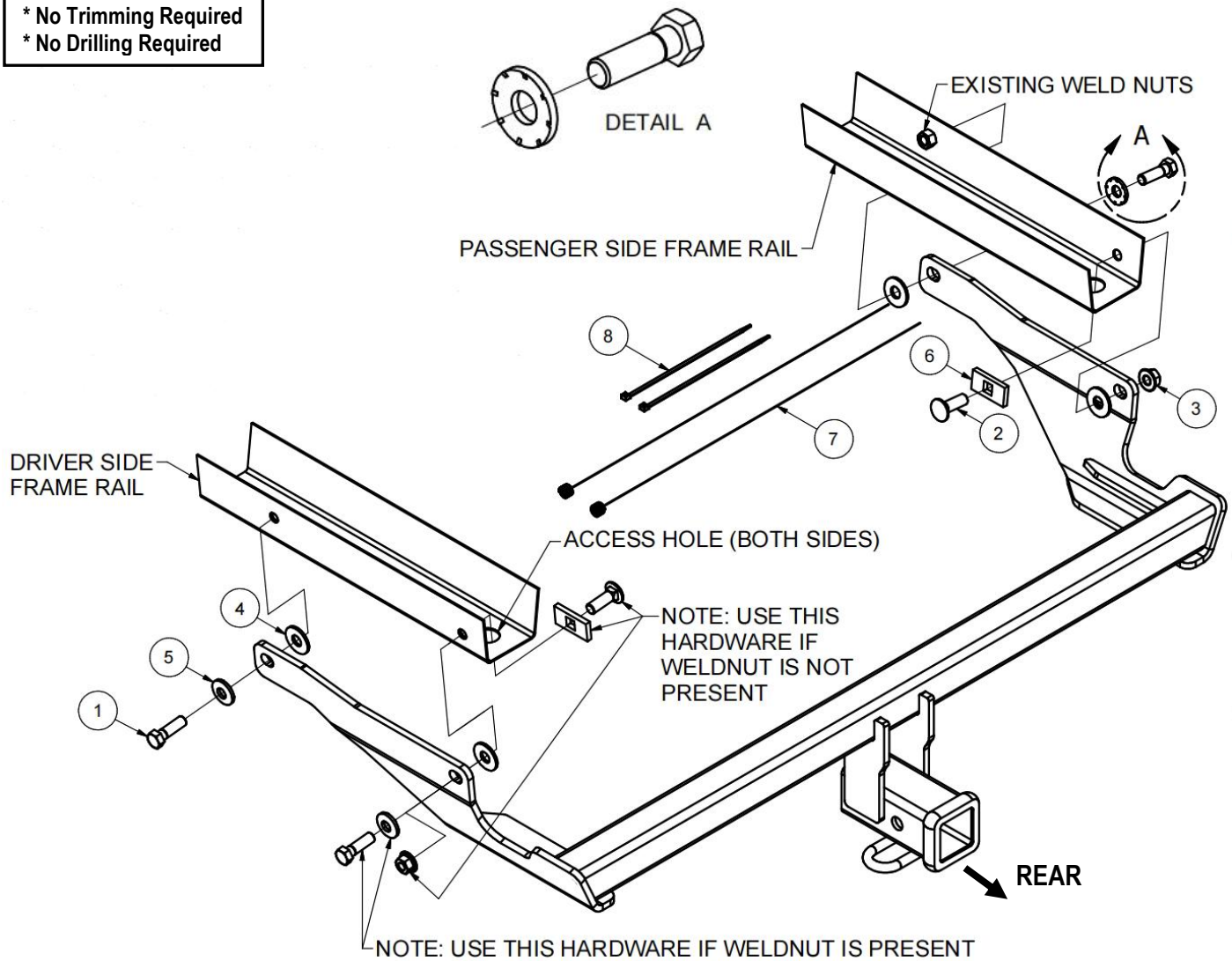

FISHWIRE TECHNIQUE

INSERT COILED END OF FISHWIRE TOOL THROUGH HITCH MOUNTING HOLE IN VEHICLE FRAME RAIL AND OUT THE ACCESS HOLE. PASS COILED END OF FISHWIRE THROUGH SPACER AND THREAD BOLT INTO COIL. KINK WIRE TO KEEP SPACER SEPARATE FROM BOLT AS SHOWN. PULL FISHWIRE, SPACER, AND BOLT THROUGH FRAME AND OUT MOUNTING HOLE. USE FISHWIRE TO GUIDE HITCH DURING MOUNTING AND PREVENT LOSS OF BOLT / SPACER INSIDE FRAME RAIL.

NOTE: SOME VEHICLES MAY FISHWIRE THROUGH END OF FRAME







WELDNUT CLEANING

To remove debris from weldnuts in frame, spray lubricant or compressed air into hole. For heavy debris, use a small wire brush. (Be careful not to damage threads).

The instruction here is for your reference only. We strongly recommend the professional installer for best result. We are not responsible for any damage caused by the installation. Thank you for choosing our product!

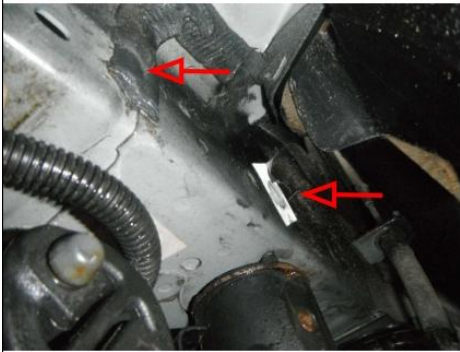









Hitch Installation Instruction

Part#	HT-R30315	Application	For 2013-2024 Mazda CX-5 Excluding Diesel
Step	Description		
1	Remove plastic underbody panel under rear bumper (if present) by removing two plastic fasteners with a flat head screwdriver. Return panel & fasteners to vehicle owner.		
			
2	Remove tape on the side of vehicle frame rails to expose mounting locations. Trim any excess seam seal (if it will interfere with hitch).		
			
3	Remove plastic insert (if present) &/or electrical harness clip between hitch mounting locations on passenger side frame rail. Unfasten electrical harness clip on outside of the driver side frame rail & follow harness to unfasten nearest clip towards center of vehicle.		
			
4	Lower exhaust by removing two to four (depending on vehicle) rearmost rubber hangers. Leave rubber hangers attached to the vehicle.		
			

The instruction here is for your reference only. We strongly recommend the professional installer for best result. We are not responsible for any damage caused by the installation. Thank you for choosing our product!



Hitch Installation Instruction

Part#	HT-R30315	Application	For 2013-2024 Mazda CX-5 Excluding Diesel
5	To ease installation tape four M12 flat washers into position on the inside of hitch side plates.		
			
6	Fishwire M12 carriage bolt with spacer in through access hole and out rearmost mounting location in the passenger frame rail. Repeat on rearmost mounting location in driver side frame rail (if there is no weldnut in frame). Leave hardware fully inside of frame rail(s) with fishwire(s) attached. See FISHWIRE TECHNIQUE diagram on page 2.		
			
7	Thread fishwire(s) through rearmost hitch mounting holes. Pull bumper fascia rearward and exhaust downward to get hitch into position.		
			
8	Insert M12 bolts with conical toothed washers. Be sure the tooth side of washers are against the hitch and the flat washers clamped in position between the hitch and frame rail.		
			

The instruction here is for your reference only. We strongly recommend the professional installer for best result. We are not responsible for any damage caused by the installation. Thank you for choosing our product!

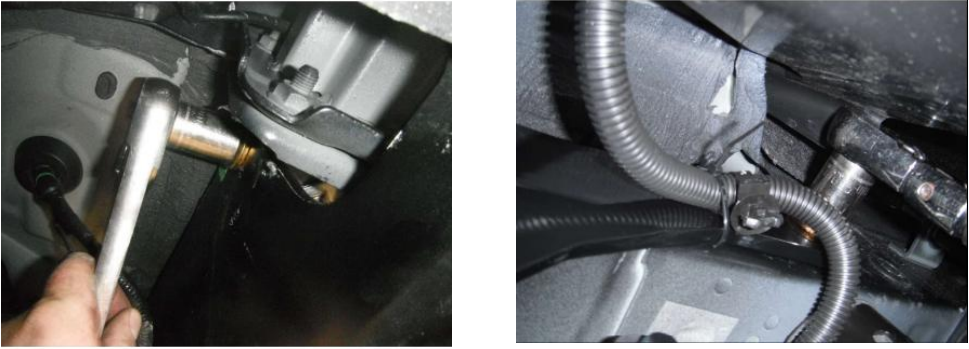

Hitch Installation Instruction

Part#	HT-R30315	Application	For 2013-2024 Mazda CX-5 Excluding Diesel
9	Pull M12 hardware into position & remove fishwire(s). Fasten with M12 hex flange nut(s). Re-secure harness which was unfastened in step 3. Wrap cable tie(s) around hitch mounting plate(s) and harness. Pull tight & trim excess cable tie.		
			
10	Torque all M12 Carriage bolt to 58 ft-lbs & M12 Hex bolt to 86 ft-lbs.		
			
***Periodically Check The Receiver Hitch To Ensure That All Fasteners *** Are Tight & All Structural Components Are Sound.			

The instruction here is for your reference only. We strongly recommend the professional installer for best result. We are not responsible for any damage caused by the installation. Thank you for choosing our product!